

## II

(Non-legislative acts)

## REGULATIONS

## COMMISSION REGULATION (EU) No 260/2014

of 24 January 2014

**amending, for the purpose of its adaptation to technical progress, Regulation (EC) No 440/2008 laying down test methods pursuant to Regulation (EC) No 1907/2006 of the European Parliament and of the Council on the Registration, Evaluation, Authorisation and Restriction of Chemicals (REACH)**

(Text with EEA relevance)

THE EUROPEAN COMMISSION,

Having regard to the Treaty on the Functioning of the European Union,

Having regard to Regulation (EC) No 1907/2006 of the European Parliament and of the Council of 18 December 2006 concerning the Registration, Evaluation, Authorisation and Restriction of Chemicals (REACH), establishing a European Chemicals Agency, amending Directive 1999/45/EC and repealing Council Regulation (EEC) No 793/93 and Commission Regulation (EC) No 1488/94 as well as Council Directive 76/769/EEC and Commission Directives 91/155/EEC, 93/67/EEC, 93/105/EC and 2000/21/EC<sup>(1)</sup>, and in particular Article 13(3) thereof,

Whereas:

(1) Commission Regulation (EC) No 440/2008<sup>(2)</sup> contains the test methods for the purposes of the determination of the physico-chemical properties, toxicity and eco-toxicity of substances to be applied for the purposes of Regulation (EC) No 1907/2006.

(2) It is necessary to update Regulation (EC) No 440/2008 to include with priority new and updated alternative test methods recently adopted by the OECD, in order to obtain a reduction of the number of animals to be used for experimental purposes, in accordance with Directive 2010/63/EU of the European Parliament and of the Council of 22 September 2010 on the protection

of animals used for scientific purposes<sup>(3)</sup> and Council Directive 86/609/EEC of 24 November 1986 on the approximation of laws, regulations and administrative provisions of the Member States regarding the protection of animals used for experimental and other scientific purposes<sup>(4)</sup>.

(3) The adaptation contains two methods for the determination of physicochemical properties including an update of the water solubility test method and a new partition coefficient test method relevant for the persistent, bioaccumulative and toxic (PBT) assessment; four new and one updated method for the determination of ecotoxicity and environmental fate and behaviour; nine methods for the determination of toxicity and other health effects including four inhalation toxicity test methods, which include an update of three methods and one new method to reduce the number of animals used and to improve assessment of effects, an update of the repeat dose 28-day oral toxicity test method to include parameters for assessment of endocrine activity, an update of the toxicokinetics test method relevant for the design and understanding of toxicological studies and an update of chronic, carcinogenicity and combined chronic and carcinogenicity test methods.

(4) Regulation (EC) No 440/2008 should therefore be amended accordingly.

(5) The measures provided for in this Regulation are in accordance with the opinion of the Committee established under Article 133 of Regulation (EC) No 1907/2006,

<sup>(1)</sup> OJ L 396, 30.12.2006, p. 1.

<sup>(2)</sup> OJ L 142, 31.5.2008, p. 1.

<sup>(3)</sup> OJ L 276, 20.10.2010, p. 33.

<sup>(4)</sup> OJ L 358, 18.12.1986, p. 1.

HAS ADOPTED THIS REGULATION:

*Article 1*

The Annex to Regulation (EC) No 440/2008 is amended in accordance with the Annex to this Regulation.

*Article 2*

This Regulation shall enter into force on the third day following that of its publication in the *Official Journal of the European Union*.

This Regulation shall be binding in its entirety and directly applicable in all Member States.

Done at Brussels, 24 January 2014.

*For the Commission*  
*The President*  
José Manuel BARROSO

---

## ANNEX

The Annex to Regulation (EC) No 440/2008 is amended as follows:

- (1) Chapter A.6 is replaced by the following:

## ‘A.6. WATER SOLUBILITY

## INTRODUCTION

1. This Test Method is equivalent to OECD Test Guideline (TG) 105 (1995). This Test Method is a revised version of the original TG 105 which was adopted in 1981. There is no difference of substance between the current version and that from 1981. Mainly the format has been changed. The revision was based on the EU Test Method “Water Solubility” <sup>(1)</sup>.

## INITIAL CONSIDERATIONS

2. The water solubility of a substance can be considerably affected by the presence of impurities. This Test Method addresses the determination of the solubility in water of essentially pure substances which are stable in water and not volatile. Before determining water solubility, it is useful to have some preliminary information on the test substance, like structural formula, vapour pressure, dissociation constant and hydrolysis as a function of pH.
3. Two methods, the column elution method and the flask method which cover respectively solubilities below and above  $10^{-2}$  g/l are described in this Test Method. A simple preliminary test is also described. It allows the determination of approximately the appropriate amount of sample to be used in the final test, as well as the time necessary to achieve saturation.

## DEFINITIONS AND UNITS

4. The water solubility of a substance is the saturation mass concentration of the substance in water at a given temperature.
5. Water solubility is expressed in mass of solute per volume of solution. The SI unit is  $\text{kg/m}^3$  but g/l may also be used.

## REFERENCE CHEMICALS

6. Reference chemicals do not need to be employed when investigating a test substance.

## DESCRIPTION OF THE METHODS

**Test conditions**

7. The test is preferably run at  $20 \pm 0,5$  °C. The chosen temperature should be kept constant in all relevant parts of the equipment.

**Preliminary test**

8. In a stepwise procedure, increasing volumes of water are added at room temperature to approximately 0,1 g of the sample (solid test substances must be pulverized) in a 10 ml glass-stoppered measuring cylinder. After each addition of an amount of water, the mixture is shaken for 10 minutes and is visually checked for any undissolved parts of the sample. If, after addition of 10 ml of water, the sample or parts of it remain undissolved, the experiment is continued in a 100 ml measuring cylinder. The approximate solubility is given in Table 1 below under that volume of water in which complete dissolution of the sample occurs. When the solubility is low, a long time may be required to dissolve a test substance and at least 24 hours should be allowed. If, after 24 hours, the test substance is still not dissolved, more time (up to 96 hours) should be allowed or further dilution should be attempted to ascertain whether the column elution method or flask method should be used.

Table 1

ml of water for 0,1 g soluble	0,1	0,5	1	2	10	100	> 100
approximate solubility in g/l	> 1 000	1 000 to 200	200 to 100	100 to 50	50 to 10	10 to 1	< 1

### Column elution method

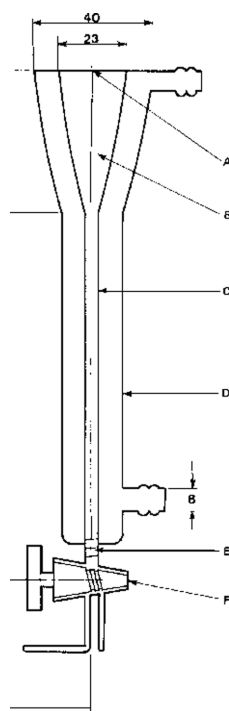
#### Principle

9. This method is based on the elution of a test substance with water from a micro-column which is charged with an inert support material, previously coated with an excess of the test substance (2). The water solubility is given by the mass concentration of the eluate when this has reached a plateau as a function of time.

#### Apparatus

10. The apparatus consists of a microcolumn (Figure 1), maintained at constant temperature. It is connected either to a recirculating pump (Figure 2) or to a levelling vessel (Figure 3). The microcolumn contains an inert support held in place by a small plug of glasswool which also serves to filter out particles. Possible materials which can be employed for the support are glass beads, diatomaceous earth, or other inert materials.
11. The microcolumn shown in Figure 1 is suitable for the set-up with recirculating pump. It has a head space providing for five bed volumes (discarded at the start of the experiment) and the volume of five samples (withdrawn for analysis during the experiment). Alternatively, the size can be reduced if water can be added to the system during the experiment to replace the initial five bed volumes removed with impurities. The column is connected with tubing made of an inert material to the recirculating pump, capable of delivering approximately 25 ml/h. The recirculating pump can be, for example, a peristaltic or membrane pump. Care must be taken that no contamination and/or adsorption occur with the tube material.
12. A schematic arrangement using a levelling vessel is shown in Figure 3. In this arrangement the microcolumn is fitted with a one way stopcock. The connection to the levelling vessel consists of a ground glass joint and tubing made of an inert material. The flow rate from the levelling vessel should be approximately 25 ml/h.

Figure 1

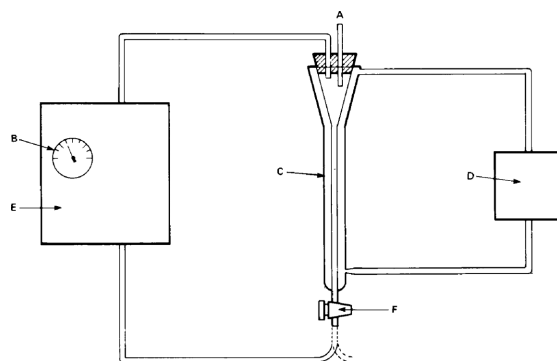


Dimensions in mm

- A. Connection for ground glass joint
- B. Headspace
- C. Interior 5
- D. Exterior 19
- E. Plug of glass wool
- F. Stopcock

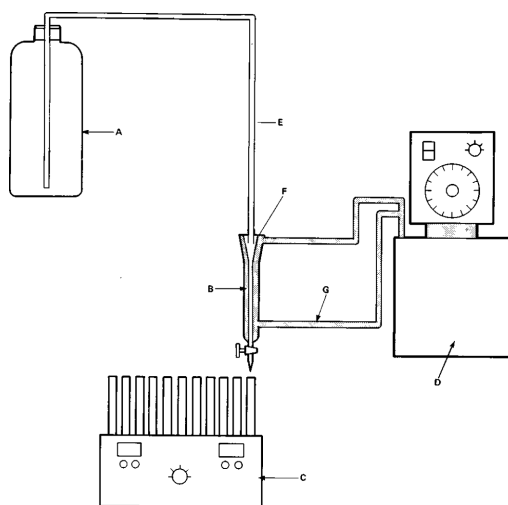


Figure 2



- A. Atmospheric equilibration
- B. Flowmeter
- C. Microcolumn
- D. Thermostatically controlled circulating pump
- E. Recirculating pump
- F. Two-way valve for sampling

Figure 3



- A. Levelling vessel (e.g. 2,5 litres chemical flask)
- B. Column
- C. Fraction accumulator
- D. Thermostat
- E. Teflon tubing
- F. Ground glass joint
- G. Water line (between thermostat and column, inner diameter approximately 8 mm)

13. Approximately 600 mg of support material is transferred to a 50 ml round-bottom flask. A suitable amount of test substance is dissolved in a volatile solvent of analytical reagent quality and an appropriate amount of this solution is added to the support material. The solvent is completely evaporated, e.g. using a rotary evaporator, as otherwise water saturation of the support will not be achieved during the elution step because of partitioning on the surface. The loaded support material is soaked for two hours in approximately 5 ml of water and the suspension is poured into the microcolumn. Alternatively, dry loaded support material may be poured into the water-filled microcolumn and two hours are allowed for equilibrating.

14. The loading of the support material may cause problems, leading to erroneous results, e.g. when the test substance is deposited as an oil. These problems should be examined and the details reported.

*Procedure using a recirculating pump*

15. The flow through the column is started. It is recommended that a flow rate of approximately 25 ml/h, corresponding to 10 bed volumes per hour for the column described, be used. At least the first five bed volumes are discarded to remove water soluble impurities. Following this, the pump is allowed to run until equilibrium is established, as defined by five successive samples whose concentrations do not differ by more than  $\pm 30\%$  in a random fashion. These samples should be separated from each other by time intervals corresponding to the passage of at least ten bed volumes. Depending on the analytical method used, it may be preferable to establish a concentration/time curve to show that equilibrium is reached.

*Procedure using a levelling vessel*

16. Successive eluate fractions should be collected and analysed by the chosen method. Fractions from the middle eluate range, where the concentrations are constant within  $\pm 30\%$  in at least five consecutive fractions, are used to determine the solubility.
17. Double distilled water is the preferred eluent. Deionized water with a resistivity above 10 megohms/cm and total organic carbon content below 0,01 % can also be used.
18. Under both procedures, a second run is performed at half the flow rate of the first. If the results of the two runs are in agreement, the test is satisfactory. If the measured solubility is higher with the lower flow rate, then the halving of the flow rate must continue until two successive runs give the same solubility.
19. Under both procedures, the fractions should be checked for the presence of colloidal matter by examination of the Tyndall effect. The presence of particles invalidates the test and the test should be repeated after improvement of the filtering action of the column.
20. The pH of each sample should be measured, preferably by using special indicator strips.

**Flask method**

*Principle*

21. The test substance (solids must be pulverized) is dissolved in water at a temperature somewhat above the test temperature. When saturation is achieved, the mixture is cooled and kept at the test temperature. Alternatively, and if it is assured by appropriate sampling that the saturation equilibrium is reached, the measurement can be performed directly at the test temperature. Subsequently, the mass concentration of the test substance in the aqueous solution, which must not contain any undissolved particles, is determined by a suitable analytical method (3).

*Apparatus*

22. The following materials are needed:
- normal laboratory glassware and instrumentation;
  - a device for the agitation of solutions under controlled constant temperature;
  - if required for emulsions, a centrifuge (preferably thermostated); and
  - analytical equipment.

*Procedure*

23. The quantity of test substance necessary to saturate the desired volume of water is estimated from the preliminary test. About five times that quantity is weighed into each of three glass vessels fitted with glass stoppers (e.g. centrifuge tubes, flasks). A volume of water, chosen in function of the analytical method and solubility range, is added to each vessel. The vessels are tightly stoppered and then agitated at 30 °C. A shaking or stirring device capable of operating at constant temperature should be used, e.g. magnetic stirring in a thermostated water bath. After one day, one of the vessels is equilibrated for 24 hours at the test temperature with occasional shaking. The contents of the vessel are then centrifuged at the test temperature and the concentration of the test substance in the clear aqueous phase is determined by a suitable analytical method.

The other two flasks are treated similarly after initial equilibration at 30 °C for two and three days respectively. If the concentrations measured in at least the two last vessels do not differ by more than 15 %, the test is satisfactory. If the results from vessels 1, 2 and 3 show a tendency of increasing values, the whole test should be repeated using longer equilibration times.

24. The test can also be performed without pre-incubation at 30 °C. In order to estimate the rate of establishment of the saturation equilibrium, samples are taken until the stirring time no longer influences the concentrations measured.
25. The pH of each sample should be measured, preferably by using special indicator strips.

#### **Analytical determinations**

26. A substance-specific method is preferred since small amounts of soluble impurities can cause large errors in the measured solubility. Examples of such methods are: gas or liquid chromatography, titration, photometry, voltametry.

#### DATA AND REPORTING

##### **Data**

###### *Column elution method*

27. For each run, the mean value and standard deviation from at least five consecutive samples taken from the saturation plateau should be calculated. The mean values obtained from two tests with different flows should not differ by more than 30 %.

###### *Flask method*

28. The individual results from each of the three flasks, which should not differ by more than 15 %, are averaged.

##### **Test Report**

###### *Column elution method*

29. The test report must include the following information:
- the results of the preliminary test
  - chemical identity and impurities (preliminary purification step, if any)
  - the concentrations, flow rates and pH for each sample
  - the means and standard deviations from at least five samples from the saturation plateau of each run
  - the average of at least two successive runs
  - the temperature of the water during the saturation process
  - the method of analysis
  - the nature of the support material
  - loading of the support material
  - solvent used
  - evidence of any chemical instability of the substance during the test
  - all information relevant for the interpretation of the results, in particular with regard to impurities and physical state of the test substance.

###### *Flask method*

30. The test report must include the following information:
- the results of the preliminary test
  - chemical identity and impurities (preliminary purification step, if any)

- the individual analytical determinations and the average where more than one value was determined for each flask
- the pH of each sample
- the average of the values for different flasks which were in agreement
- the test temperature
- the analytical method
- evidence of any chemical instability of the substance during the test
- all information relevant for the interpretation of the results, in particular with regard to impurities and physical state of the test substance.

#### LITERATURE:

- (1) Commission Directive 92/69/EEC of 31 July 1992 adapting to technical progress for the seventeenth time Council Directive 67/548/EEC on the approximation of laws, regulations and administrative provisions relating to the classification, packaging and labelling of dangerous substances (OJ L 383, 29.12.1992, p. 113).
  - (2) NF T 20-045 (AFNOR) (September 1985). Chemical products for industrial use — Determination of water solubility of solids and liquids with low solubility — Column elution method.
  - (3) NF T 20-046 (AFNOR) (September 1985). Chemical products for industrial use — Determination of water solubility of solids and liquids with high solubility — Flask method'.
- (2) Chapter A.23 is added:

#### 'A.23 PARTITION COEFFICIENT (1-OCTANOL/WATER): SLOW-STIRRING METHOD

##### INTRODUCTION

1. This Test Method is equivalent to OECD Test Guideline (TG) 123 (2006). 1-octanol/water partition coefficient ( $P_{OW}$ ) values up to a  $\log P_{OW}$  of 8,2 have been accurately determined by the slow-stirring method (1). Therefore it is a suitable experimental approach for the direct determination of  $P_{OW}$  of highly hydrophobic substances.
2. Other methods for the determination of the 1-octanol/water partition coefficient ( $P_{OW}$ ) are the "shake-flask" method (2), and the determination of the  $P_{OW}$  from reversed phase HPLC-retention behaviour (3). The "shake-flask" method is prone to artifacts due to transfer of octanol micro-droplets into the aqueous phase. With increasing values of  $P_{OW}$  the presence of these droplets in the aqueous phase leads to an increasing over-estimation of the concentration of the test substance in the water. Therefore, its use is limited to substances with  $\log P_{OW} < 4$ . The second method relies on solid data of directly determined  $P_{OW}$  values to calibrate the relationship between HPLC-retention behaviour and measured values of  $P_{OW}$ . A draft OECD guideline was available for determining 1-octanol/water partition coefficients of ionisable substances (4) but shall no longer be used.
3. This Test Method has been developed in The Netherlands. The precision of the methods described here has been validated and optimized in a ring-test validation study in which 15 laboratories participated (5).

##### INITIAL CONSIDERATIONS

##### Significance and use

4. For inert organic substances highly significant relationships have been found between 1-octanol/water partition coefficients ( $P_{OW}$ ) and their bioaccumulation in fish. Moreover,  $P_{OW}$  has been demonstrated to be correlated to fish toxicity as well as to sorption of chemicals to solids such as soils and sediments. An extensive overview of the relationships has been given in reference (6).

5. A wide variety of relationships between the 1-octanol/water partition coefficient and other substance properties of relevance to environmental toxicology and chemistry have been established. As a consequence, the 1-octanol/water partition coefficient has evolved as a key parameter in the assessment of the environmental risk of chemicals as well as in the prediction of fate of chemicals in the environment.

#### Scope

6. The slow-stirring experiment is thought to reduce the formation of micro-droplets from 1-octanol droplets in the water phase. As a consequence, overestimation of the aqueous concentration due to test substance molecules associated to such droplets does not occur. Therefore, the slow-stirring method is particularly suitable for the determination of  $P_{OW}$  for substances with expected  $\log P_{OW}$  values of 5 and higher, for which the shake-flask method (2) is prone to yield erroneous results.

#### DEFINITION AND UNITS

7. The partition coefficient of a substance between water and a lipophilic solvent (1-octanol) characterizes the equilibrium distribution of the chemical between the two phases. The partition coefficient between water and 1-octanol ( $P_{OW}$ ) is defined as the ratio of the equilibrium concentrations of the test substance in 1-octanol saturated with water ( $C_O$ ) and water saturated with 1-octanol ( $C_W$ ).

$$P_{OW} = C_O/C_W$$

As a ratio of concentrations it is dimensionless. Most frequently it is given as the logarithm to the base 10 ( $\log P_{OW}$ ).  $P_{OW}$  is temperature dependent and reported data should include the temperature of the measurement.

#### PRINCIPLE OF THE METHOD

8. In order to determine the partitioning coefficient, water, 1-octanol, and the test substance are equilibrated with each other at constant temperature. Then the concentrations of the test substance in the two phases are determined.
9. The experimental difficulties associated with the formation of micro-droplets during the shake-flask experiment can be reduced in the slow-stirring experiment proposed here. In the slow-stirring experiment, water, 1-octanol and the test substance are equilibrated in a thermostated stirred reactor. Exchange between the phases is accelerated by stirring. The stirring introduces limited turbulence which enhances the exchange between 1-octanol and water without micro-droplets being formed (1).

#### APPLICABILITY OF THE TEST

10. Since the presence of substances other than the test substance might influence the activity coefficient of the test substance, the test substance should be tested as a pure substance. The highest purity commercially available should be employed for the 1-octanol/water partition experiment.
11. The present method applies to pure substances that do not dissociate or associate and that do not display significant interfacial activity. It can be applied to determine the 1-octanol/water partition ratio of such substances and of mixtures. When the method is used for mixtures, the 1-octanol/water partition ratios determined are conditional and depend on the chemical composition of the mixture tested and on the electrolyte composition employed as aqueous phase. Provided additional steps are taken, the method is also applicable to dissociating or associating compounds (paragraph 12).
12. Due to the multiple equilibria in water and 1-octanol involved in the 1-octanol/water partitioning of dissociating substances such as organic acids and phenols, organic bases, and organometallic substances, the 1-octanol/water partition ratio is a conditional constant strongly dependent on electrolyte composition (7)(8). Determination of the 1-octanol/water partition ratio therefore requires that pH and electrolyte composition be controlled in the experiment and reported. Expert judgement has to be employed in the evaluation of these partition ratios. Using the value of dissociation constant(s), suitable pH-values need to be selected, such that a partitioning ratio is determined for each ionization state. Non-complexing buffers must be used when testing organometallic compounds (8). Taking the existing knowledge on the aqueous chemistry (complexation constants, dissociation constants) into account, the experimental conditions should be chosen in such a manner that the speciation of the test substance in the aqueous phase can be estimated. The ionic strength should be identical in all experiments by employing a background electrolyte.
13. Difficulties in the test may arise in conducting the test for substances with low water solubility or high  $P_{OW}$ , due to the fact that the concentrations in the water become very low such that their accurate determination is difficult. This Test Method provides guidance on how to deal with this problem.

## INFORMATION ON THE TEST SUBSTANCE

14. Chemical reagents should be of analytical grade or of higher purity. The use of non-labelled test substances with known chemical composition and preferably at least 99 % purity, or of radiolabelled test substances with known chemical composition and radiochemical purity, is recommended. In the case of short half-life tracers, decay corrections should be applied. In the case of radiolabelled test substances, a chemical specific analytical method should be employed to ensure that the measured radioactivity is directly related to the test substance.
15. An estimate of  $\log P_{OW}$  may be obtained by using commercially available software for estimation of  $\log P_{OW}$ , or by using the ratio of the solubilities in both solvents.
16. Before carrying out a slow-stirring experiment for determination of  $P_{OW}$ , the following information on the test substance should be available:
  - (a) structural formula
  - (b) suitable analytical methods for determination of the concentration of the substance in water and 1-octanol
  - (c) dissociation constant(s) of ionisable substances (OECD Guideline 112 (9))
  - (d) aqueous solubility (10)
  - (e) abiotic hydrolysis (11)
  - (f) ready biodegradability (12)
  - (g) vapour pressure (13).

## DESCRIPTION OF THE METHOD

**Equipment and apparatus**

17. Standard laboratory equipment is required, in particular, the following:
  - magnetic stirrers and Teflon coated magnetic stir bars are employed to stir the water phase;
  - analytical instrumentation, suitable for determination of the concentration of the test substance at the expected concentrations;
  - stirring-vessel with a tap at the bottom. Dependent on the estimate of  $\log P_{OW}$  and the Limit of Detection (LOD) of the test compound, the use of a reaction vessel of the same geometry larger than one litre has to be considered, so that a sufficient volume of water can be obtained for chemical extraction and analysis. This will result in higher concentrations in the water extract and thus a more reliable analytical determination. A table giving estimates of the minimum volume needed, the LOD of the compound, its estimated  $\log P_{OW}$  and its water solubility is given in Appendix 1. The table is based on the relationship between  $\log P_{OW}$  and the ratio between the solubilities in octanol and water, as presented by Pinsuwan *et al.* (14):

$$\log P_{OW} = 0,88 \log SR + 0,41$$

where

$SR = S_{oct}/S_w$  (in molarity);

and the relationship given by Lyman (15) for predicting water solubility. Water solubilities calculated with the equation given in Appendix 1 must be seen as a first estimate. It should be noted that the user is free to generate an estimate of water solubility by means of any relationship that is considered to better represent the relationship between hydrophobicity and solubility. For solid compounds, inclusion of melting point in the prediction of solubility is for instance recommended. In case a modified equation is used, it should be ascertained that the equation for calculation of solubility in octanol is still valid. A schematic drawing of a glass-jacketed stirring-vessel with a volume of ca. one litre is given in Appendix 2. The proportions of the vessel shown in Appendix 2 have proven favourable and should be maintained when apparatus of a different size is used;

- a means for keeping the temperature constant during the slow-stirring experiment is essential.

18. Vessels should be made from inert material such that adsorption to vessel surfaces is negligible.

#### Preparation of the test solutions

19. The  $P_{OW}$  determination should be carried out with the highest purity 1-octanol that is commercially available (at least + 99 %). Purification of 1-octanol by extraction with acid, base and water and subsequent drying is recommended. In addition, distillation can be used to purify 1-octanol. Purified 1-octanol is to be used to prepare standard solutions of the test substances. Water to be used in the  $P_{OW}$  determination should be glass or quartz distilled, or obtained from a purification system, or HPLC-grade water may be used. Filtration through a 0,22  $\mu\text{m}$  filter is required for distilled water, and blanks should be included to check that no impurities are in the concentrated extracts that may interfere with the test substance. If a glass fibre filter is used, it should be cleaned by baking for at least three hours at 400 °C.
20. Both solvents are mutually saturated prior to the experiment by equilibrating them in a sufficiently large vessel. This is accomplished by slow-stirring the two-phase system for two days.
21. An appropriate concentration of test substance is selected and dissolved in 1-octanol (saturated with water). The 1-octanol/water partition coefficient needs to be determined in dilute solutions in 1-octanol and water. Therefore the concentration of the test substance should not exceed 70 % of its solubility with a maximum concentration of 0,1 M in either phase (1). The 1-octanol solutions used for the experiment must be devoid of suspended solid test substance.
22. The appropriate amount of test substance is dissolved in 1-octanol (saturated with water). If the estimate of  $\log P_{OW}$  exceeds five, care has to be taken that the 1-octanol solutions used for the experiment are devoid of suspended solid test substance. To that end, the following procedure for chemicals with an estimated value of  $\log P_{OW} > 5$  is followed:
- the test substance is dissolved in 1-octanol (saturated with water);
  - the solution is given sufficient time for the suspended solid substance to settle out. During the settling period, the concentration of the test substance is monitored;
  - after the measured concentrations in the 1-octanol-solution have attained stable values, the stock solution is diluted with an appropriate volume of 1-octanol;
  - the concentration of the diluted stock solution is measured. If the measured concentration is consistent with the dilution, the diluted stock solution can be employed in the slow-stirring experiment.

#### Extraction and analysis of samples

23. A validated analytical method should be used for the assay of test substance. The investigators have to provide evidence that the concentrations in the water saturated 1-octanol as well as in the 1-octanol saturated water phase during the experiment are above the method limit of quantification of the analytical procedures employed. Analytical recoveries of the test substance from the water phase and from the 1-octanol phase need to be established prior to the experiment in those cases for which extraction methods are necessary. The analytical signal needs to be corrected for blanks and care should be taken that no carry-over of analyte from one sample to another can occur.
24. Extraction of the water phase with an organic solvent and preconcentration of extract are likely to be required prior to analysis, due to rather low concentrations of hydrophobic test substances in the water phase. For the same reason it is necessary to reduce eventual blank concentrations. To that end, it is necessary to employ high purity solvents, preferably solvents for residue analysis. Moreover, working with carefully pre-cleaned (e.g. solvent washing or baking at elevated temperature) glassware can help to avoid cross-contamination.
25. An estimate of  $\log P_{OW}$  may be obtained from an estimation program or by expert judgment. If the value is higher than six then blank corrections and analyte carry-over need to be monitored closely. Similarly, if the estimate of  $\log P_{OW}$  exceeds six, the use of a surrogate standard for recovery correction is mandatory, so that high preconcentration factors can be reached. A number of software programs for the estimation of  $\log P_{OW}$  are commercially available<sup>(1)</sup>, e.g. Clog P (16), KOWWIN (17), ProLogP (18) and ACD log P (19). Descriptions of the estimation approaches can be found in references (20-22).

<sup>(1)</sup> This information is only given for the convenience of users. Other equivalent computer programmes may be used if they can be shown to produce the same results.

26. The limits of quantification (LOQ) for determination of the test substance in 1-octanol and water are established using accepted methods. As a rule of thumb, the method limit of quantification can be determined as the concentration in water or 1-octanol that produces a signal to noise ratio of ten. A suitable extraction and pre-concentration method should be selected and analytical recoveries should also be specified. A suitable pre-concentration factor is selected in order to obtain a signal of the required size upon analytical determination.
27. On the basis of the parameters of the analytical method and the expected concentrations, an approximate sample size required for an accurate determination of the compound concentration is determined. The use of water samples that are too small to obtain a sufficient analytical signal should be avoided. Also, the use of excessively large water samples should be avoided, since otherwise there might be too little water left for the minimum number of analyses required ( $n = 5$ ). In Appendix 1, the minimum sample volume is indicated as a function of the vessel volume, the LOD of the test substance and the solubility of the test substance.
28. Quantification of the test substances occurs by comparison with calibration curves of the respective compound. The concentrations in the samples analysed must be bracketed by concentrations of standards.
29. For test substances with a  $\log P_{OW}$  estimate higher than six a surrogate standard has to be spiked to the water sample prior to extraction in order to register losses occurring during extraction and pre-concentration of the water samples. For accurate recovery correction, the surrogates must have properties that are very close to, or identical with, those of the test substance. Preferably, (stable) isotopically-labelled analogues of the substances of interest (for example, perdeuterated or  $^{13}C$ -labelled) are used for this purpose. If the use of labelled stable isotopes, i.e.  $^{13}C$  or  $^2H$ , is not possible it should be demonstrated from reliable data in the LITERATURE that the physical-chemical properties of the surrogate are very close to those of the test substance. During liquid-liquid extraction of the water phase emulsions can form. They can be reduced by addition of salt and allowing the emulsion to settle overnight. Methods used for extracting and pre-concentrating the samples need to be reported.
30. Samples withdrawn from the 1-octanol phase may, if necessary, be diluted with a suitable solvent prior to analysis. Moreover, the use of surrogate standards for recovery correction is recommended for substances for which the recovery experiments demonstrated a high degree of variation in the recovery experiments (relative standard deviation  $> 10\%$ ).
31. The details of the analytical method need to be reported. This includes the method of extraction, pre-concentration and dilution factors, instrument parameters, calibration routine, calibration range, analytical recovery of the test substance from water, addition of surrogate standards for recovery correction, blank values, detection limits and limits of quantification.

### Performance of the Test

#### *Optimal 1-octanol/water volume ratios*

32. When choosing the water and 1-octanol volumes, the LOQ in 1-octanol and water, the pre-concentration factors applied to the water samples, the volumes sampled in 1-octanol and water, and the expected concentrations should be considered. For experimental reasons, the volume of 1-octanol in the slow-stirring system should be chosen such that the 1-octanol layer is sufficiently thick ( $> 0,5$  cm) in order to allow for sampling of the 1-octanol phase without disturbing it.
33. Typical phase ratios used for the determinations of compounds with  $\log P_{OW}$  of 4,5 and higher are 20 to 50 ml of 1-octanol and 950 to 980 ml of water in a one litre vessel.

#### *Test conditions*

34. During the test the reaction vessel is thermostated to reduce temperature variation to below  $1^\circ C$ . The assay should be performed at  $25^\circ C$ .
35. The experimental system should be protected from daylight by either performing the experiment in a dark room or by covering the reaction vessel with aluminium foil.
36. The experiment should be performed in a dust-free (as far as possible) environment.
37. The 1-octanol-water system is stirred until equilibrium is attained. In a pilot experiment the length of the equilibration period is assessed by performing a slow-stirring experiment and sampling water and 1-octanol periodically. The sampling time points should be interspersed by a minimum period of five hours.
38. Each  $P_{OW}$  determination has to be performed employing at least three independent slow-stirring experiments.



*Determination of the equilibration time*

39. It is assumed that the equilibrium is achieved when a regression of the 1-octanol/water concentration ratio against time over a time span of four time points yields a slope that is not significantly different from zero at a p-level of 0,05. The minimum equilibration time is one day before sampling can be started. As a rule of thumb, sampling of substances with a  $\log P_{OW}$  estimate of less than five can take place during days two and three. The equilibration might have to be extended for more hydrophobic compounds. For a compound with  $\log P_{OW}$  of 8,23 (decachlorobiphenyl) 144 hours were sufficient for equilibration. Equilibrium is assessed by means of repeated sampling of a single vessel.

*Starting the experiment*

40. At the start of the experiment the reaction vessel is filled with 1-octanol-saturated water. Sufficient time should be allowed to reach the thermostated temperature.
41. The desired amount of test substance (dissolved in the required volume of 1-octanol saturated with water) is carefully added to the reaction vessel. This is a crucial step in the experiment, since turbulent mixing of the two phases has to be avoided. To that end, the 1-octanol phase can be pipetted slowly against the wall of the experimental vessel, close to the water surface. It will subsequently flow along the glass wall and form a film above the water phase. The decantation of 1-octanol directly into the flask should always be avoided; drops of 1-octanol should not be allowed to fall directly into the water.
42. After starting the stirring, the stirring rate should be increased slowly. If the stirring motors cannot be appropriately adjusted the use of a transformer should be considered. The stirring rate should be adjusted so that a vortex at the interface between water and 1-octanol of 0,5 to maximally 2,5 cm depth is created. The stirring rate should be reduced if the vortex depth of 2,5 cm is exceeded; otherwise micro-droplets may be formed from 1-octanol droplets in the water phase, leading to an overestimation of the concentration of the test substance in the water. The maximum stirring rate of 2,5 cm is recommended on the basis of the findings in the ring-test validation study (5). It is a compromise between achieving a rapid rate of equilibration, while limiting the formation of 1-octanol micro-droplets.

*Sampling and Sample Treatment*

43. The stirrer should be turned off prior to sampling and the liquids should be allowed to stop moving. After sampling is completed, the stirrer is started again slowly, as described above, and then the stirring rate is increased gradually.
44. The water phase is sampled from a stopcock at the bottom of the reaction vessel. Always discard the dead volume of water contained in the taps (approximately 5 ml in the vessel shown in the Appendix 2). The water in the taps is not stirred and therefore not in equilibrium with the bulk. Note the volume of the water samples, and make sure that the amount of test substance present in the discarded water is taken into account when setting up a mass balance. Evaporative losses should be minimized by allowing the water to flow quiescently into the separatory funnel, such that there is no disturbance of the water/1-octanol layer.
45. 1-Octanol samples are obtained by withdrawing a small aliquot (ca. 100  $\mu$ l) from the 1-octanol layer with a 100 microlitre all glass-metal syringe. Care should be taken not to disturb the boundary. The volume of the sampled liquid is recorded. A small aliquot is sufficient, since the 1-octanol sample will be diluted.
46. Unnecessary sample transfer steps should be avoided. To that end the sample volume should be determined gravimetrically. In case of water samples this can be achieved by collecting the water sample in a separatory funnel that contains already the required volume of solvent.

## DATA AND REPORTING

47. According to the present Test Method,  $P_{OW}$  is determined by performing three slow-stirring experiments (three experimental units) with the compound under investigation employing identical conditions. The regression used to demonstrate attainment of equilibrium should be based on the results of at least four determinations of  $C_O/C_W$  at consecutive time points. This allows for calculating variance as a measure of the uncertainty of the average value obtained by each experimental unit.
48. The  $P_{OW}$  can be characterized by the variance in the data obtained for each experimental unit. This information is employed to calculate the  $P_{OW}$  as the weighted average of the results of the individual experimental units. To do so, the inverse of the variance of the results of the experimental units is employed as weight. As a result, data with a large variation (expressed as the variance) and thus with lower reliability have less influence on the result than data with a low variance.

49. Analogously, the weighted standard deviation is calculated. It characterizes the repeatability of the  $P_{OW}$  measurement. A low value of the weighted standard deviation indicates that the  $P_{OW}$  determination was very repeatable within one laboratory. The formal statistical treatment of the data is outlined below.

### Treatment of the results

#### Demonstration of attainment of equilibrium

50. The logarithm of the ratio of the concentration of the test substance in 1-octanol and water ( $\log(C_o/C_w)$ ) is calculated for each sampling time. Achievement of chemical equilibrium is demonstrated by plotting this ratio against time. A plateau in this plot that is based on at least four consecutive time points indicates that equilibrium has been attained, and that the compound is truly dissolved in 1-octanol. If not, the test needs to be continued until four successive time points yield a slope that is not significantly different from 0 at a p-level of 0,05, indicating that  $\log C_o/C_w$  is independent of time.

#### Log $P_{OW}$ -calculation

51. The value of  $\log P_{OW}$  of the experimental unit is calculated as the weighted average value of  $\log C_o/C_w$  for the part of the curve of  $\log C_o/C_w$  vs. time, for which equilibrium has been demonstrated. The weighted average is calculated by weighting the data with the inverse of the variance so that the influence of the data on the final result is inversely proportional to the uncertainty in the data.

#### Average log $P_{OW}$

52. The average value of  $\log P_{OW}$  of different experimental units is calculated as the average of the results of the individual experimental units weighted with their respective variances.

The calculation is performed as follows:

$$\log P_{OW,Av} = (\sum w_i \times \log P_{OW,i}) \times (\sum w_i)^{-1}$$

where:

$\log P_{OW,i}$  = the  $\log P_{OW}$  value of the individual experimental unit i;

$\log P_{OW,Av}$  = the weighted average value of the individual  $\log P_{OW}$  determinations;

$w_i$  = the statistical weight assigned to the  $\log P_{OW}$  value of the experimental unit i.

The reciprocal of the variance of  $\log P_{OW,i}$  is employed as  $w_i$  ( $w_i = \text{var}(\log P_{OW,i})^{-1}$ )

53. The error of the average of  $\log P_{OW}$  is estimated as the repeatability of  $\log C_o/C_w$  determined during the equilibrium phase in the individual experimental units. It is expressed as the weighted standard deviation of  $\log P_{OW,Av}$  ( $\sigma_{\log P_{OW,Av}}$ ) which in turn is a measure of the error associated with  $\log P_{OW,Av}$ . The weighted standard deviation can be computed from the weighted variance ( $\text{var}_{\log P_{OW,Av}}$ ) as follows:

$$\text{var}_{\log P_{OW,Av}} = (\sum w_i \times (\log P_{OW,i} - \log P_{OW,Av})^2) \times (\sum w_i \times (n - 1))^{-1}$$

$$\sigma_{\log P_{OW,Av}} = (\text{var}_{\log P_{OW,Av}})^{0,5}$$

The symbol n stands for the number of experimental units.

### Test Report

54. The test report should include the following information:

#### Test substance:

- common name, chemical name, CAS number, structural formula (indicating position of label when radio-labelled substance is used) and relevant physical-chemical properties (see paragraph 17)
- purity (impurities) of test substance
- label purity of labelled chemicals and molar activity (where appropriate)
- the preliminary estimate of  $\log P_{ow}$ , as well as the method used to derive the value.

*Test conditions:*

- dates of the performance of the studies
- temperature during the experiment
- volumes of 1-octanol and water at the beginning of the test
- volumes of withdrawn 1-octanol and water samples
- volumes of 1-octanol and water remaining in the test vessels
- description of the test vessels and stirring conditions (geometry of the stirring bar and of the test vessel, vortex height in mm, and when available: stirring rate) used
- analytical methods used to determine the test substance and the method limit of quantification
- sampling times
- the aqueous phase pH and the buffers used, when pH is adjusted for ionizable molecules
- number of replicates.

*Results:*

- repeatability and sensitivity of the analytical methods used
- determined concentrations of the test substance in 1-octanol and water as a function of time
- demonstration of mass balance
- temperature and standard deviation or the range of temperature during the experiment
- the regression of concentration ratio against time
- the average value  $\log P_{ow,AV}$  and its standard error
- discussion and interpretation of the results
- examples of raw data figures of representative analysis (all raw data have to be stored in accordance with GLP standards), including recoveries of surrogates, and the number of levels used in the calibration (along with the criteria for the correlation coefficient of the calibration curve), and results of quality assurance/quality control (QA/QC)
- when available: validation report of the assay procedure (to be indicated among references).

*LITERATURE:*

- (1) De Bruijn JHM, Busser F, Seinen W, Hermens J. (1989). Determination of octanol/water partition coefficients with the "slow-stirring" method. *Environ. Toxicol. Chem.* 8: 499-512.
- (2) Chapter A.8 of this Annex, Partition Coefficient.
- (3) Chapter A.8 of this Annex, Partition Coefficient.
- (4) OECD (2000). OECD Draft Guideline for the Testing of Chemicals: 122 Partition Coefficient (n-Octanol/Water): pH-Metric Method for Ionisable Substances. Paris.
- (5) Tolls J (2002). Partition Coefficient 1-Octanol/Water (Pow) Slow-Stirring Method for Highly Hydrophobic Chemicals, Validation Report. RIVM contract-Nrs 602730 M/602700/01.
- (6) Boethling RS, Mackay D (eds.) (2000). Handbook of property estimation methods for chemicals. Lewis Publishers Boca Raton, FL, USA.

- (7) Schwarzenbach RP, Gschwend PM, Imboden DM (1993). *Environmental Organic Chemistry*. Wiley, New York, NY.
  - (8) Arnold CG, Widenhaupt A, David MM, Müller SR, Haderlein SB, Schwarzenbach RP (1997). Aqueous speciation and 1-octanol-water partitioning of tributyl- and triphenyltin: effect of pH and ion composition. *Environ. Sci. Technol.* 31: 2596-2602.
  - (9) OECD (1981) OECD Guidelines for the Testing of Chemicals: 112 Dissociation Constants in Water. Paris.
  - (10) Chapter A.6 of this Annex, Water Solubility.
  - (11) Chapter C.7 of this Annex, Degradation – Abiotic Degradation Hydrolysis as a Function of pH.
  - (12) Chapter C.4 — Part II – VII (Method A to F) of this Annex, Determination of “Ready” Biodegradability.
  - (13) Chapter A.4 of this Annex, Vapour Pressure.
  - (14) Pinsuwan S, Li A and Yalkowsky S.H. (1995). Correlation of octanol/water solubility ratios and partition coefficients, *J. Chem. Eng. Data.* 40: 623-626.
  - (15) Lyman WJ (1990). Solubility in water. In: *Handbook of Chemical Property Estimation Methods: Environmental Behavior of Organic Compounds*, Lyman WJ, Reehl WF, Rosenblatt DH, Eds. American Chemical Society, Washington, DC, 2-1 to 2-52.
  - (16) Leo A, Weininger D (1989). *Medchem Software Manual*. Daylight Chemical Information Systems, Irvine, CA.
  - (17) Meylan W (1993). SRC-LOGKOW for Windows. SRC, Syracuse, N.Y.
  - (18) Compudrug L (1992). ProLogP. Compudrug, Ltd, Budapest.
  - (19) ACD. ACD logP; Advanced Chemistry Development: Toronto, Ontario M5H 3V9, Canada, 2001.
  - (20) Lyman WJ (1990). Octanol/water partition coefficient. In Lyman WJ, Reehl WF, Rosenblatt DH, eds, *Handbook of chemical property estimation*, American Chemical Society, Washington, D.C.
  - (21) Rekker RF, de Kort HM (1979). The hydrophobic fragmental constant: An extension to a 1 000 data point set. *Eur. J. Med. Chem. Chim. Ther.* 14: 479-488.
  - (22) Jübermann O (1958). Houben-Weyl, ed, *Methoden der Organischen Chemie*: 386-390.
-

## Appendix 1

**Spreadsheet for computation of minimum volumes of water required for detection of test substances of different log P<sub>ow</sub> values in aqueous phase**

## Assumptions:

- Maximum volume of individual aliquots = 10 % of total volume; 5 aliquots = 50 % of total volume.
- Concentration of test substances = 0,7 × solubility in either phase. In case of lower concentrations, larger volumes would be required.
- Volume used for LOD determination = 100 ml.
- log P<sub>ow</sub> vs. log S<sub>w</sub> and log P<sub>ow</sub> vs. SR (S<sub>oct</sub>/S<sub>w</sub>) are reasonable representations of relationships for test substances.

Estimation of S<sub>w</sub>

log P <sub>ow</sub>	Equation	log S <sub>w</sub>	S <sub>w</sub> (mg/l)
4	(-0,922 × log P <sub>ow</sub> + 4,184	0,496	3,133E+00
4,5	(-0,922 × log P <sub>ow</sub> + 4,184	0,035	1,084E+00
5	(-0,922 × log P <sub>ow</sub> + 4,184	-0,426	3,750E-01
5,5	(-0,922 × log P <sub>ow</sub> + 4,184	-0,887	1,297E-01
6	(-0,922 × log P <sub>ow</sub> + 4,184	-1,348	4,487E-02
6,5	(-0,922 × log P <sub>ow</sub> + 4,184	-1,809	1,552E-02
7	(-0,922 × log P <sub>ow</sub> + 4,184	-2,270	5,370E-03
7,5	(-0,922 × log P <sub>ow</sub> + 4,184	-2,731	1,858E-03
8	(-0,922 × log P <sub>ow</sub> + 4,184	-3,192	6,427E-04

Estimation of S<sub>oct</sub>

log P <sub>ow</sub>	Equation	S <sub>oct</sub> (mg/l)
4	log P <sub>ow</sub> = 0,88log SR + 0,41	3,763E+04
4,5	log P <sub>ow</sub> = 0,88log SR + 0,42	4,816E+04
5	log P <sub>ow</sub> = 0,88log SR + 0,43	6,165E+04
5,5	log P <sub>ow</sub> = 0,88log SR + 0,44	7,890E+04
6	log P <sub>ow</sub> = 0,88log SR + 0,45	1,010E+05
6,5	log P <sub>ow</sub> = 0,88log SR + 0,46	1,293E+05
7	log P <sub>ow</sub> = 0,88log SR + 0,47	1,654E+05
7,5	log P <sub>ow</sub> = 0,88log SR + 0,48	2,117E+05
8	log P <sub>ow</sub> = 0,88log SR + 0,49	2,710E+05

Total Mass test substance (mg)	Mass <sub>oct</sub> /Mass <sub>water</sub>	Mass <sub>H<sub>2</sub>O</sub> (mg)	Conc <sub>H<sub>2</sub>O</sub> (mg/l)	Mass <sub>oct</sub> (mg)	Conc <sub>oct</sub> (mg/l)
1 319	526	2,5017	2,6333	1 317	26 333

Total Mass test substance (mg)	Mass <sub>oct</sub> /Mass <sub>water</sub>	Mass <sub>H<sub>2</sub>O</sub> (mg)	Conc <sub>H<sub>2</sub>O</sub> (mg/l)	Mass <sub>oct</sub> (mg)	Conc <sub>oct</sub> (mg/l)
1 686	1 664	1,0127	1,0660	1 685	33 709
2 158	5 263	0,4099	0,4315	2 157	43 149
2 762	16 644	0,1659	0,1747	2 762	55 230
3 535	52 632	0,0672	0,0707	3 535	70 691
4 524	1664 36	0,0272	0,0286	4 524	90 480
5 790	5263 16	0,0110	0,0116	5 790	115 807
7 411	1 664 357	0,0045	0,0047	7 411	148 223
9 486	5 263 158	0,0018	0,0019	9 486	189 713

*Computation of volumes*

**Minimum volume required for H<sub>2</sub>O phase at each LOD concentration**

log K <sub>ow</sub>	LOD (micrograms/l)→	0,001	0,01	0,10	1,00	10
4		0,04	0,38	3,80	38	380
4,5		0,09	0,94	9,38	94	938
5		0,23	2,32	23,18	232	2 318
5,5		0,57	5,73	57,26	573	5 726
6		1,41	14,15	141	1 415	14 146
6,5		3,50	34,95	350	3 495	34 950
7		8,64	86,35	864	8 635	86 351
7,5		21,33	213	2 133	21 335	213 346
8		52,71	527	5 271	52 711	527 111
Volume used for LOD (l)	0,1					

*Key to Computations*

Represents < 10 % of total volume of aqueous phase, 1 litre equilibration vessel.

Represents < 10 % of total volume of aqueous phase, 2 litre equilibration vessel.

Represents < 10 % of total volume of aqueous phase, 5 litre equilibration vessel.

Represents < 10 % of total volume of aqueous phase, 10 litre equilibration vessel.

Exceeds 10 % of even the 10 liter equilibration vessel.

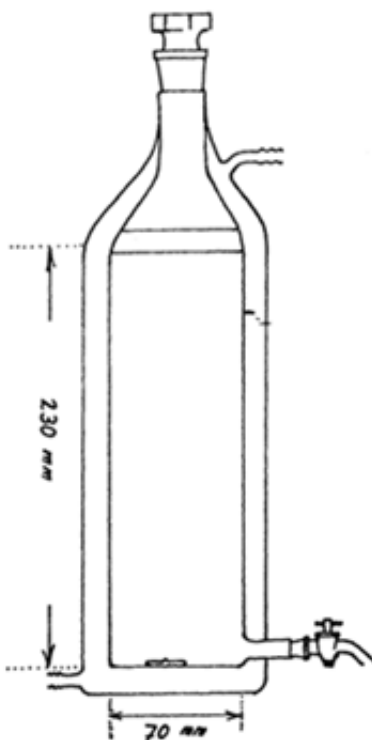
**Overview of volumes required, as a function of water solubility and Log P<sub>ow</sub>**

Minimum volume required for H<sub>2</sub>O phase at each LOD concentration (ml)

log P <sub>ow</sub>	S <sub>w</sub> (mg/l)	LOD (micrograms/l)→	0,001	0,01	0,10	1,00	10
4	10		0,01	0,12	1,19	11,90	118,99
	5		0,02	0,24	2,38	23,80	237,97
	3		0,04	0,40	3,97	39,66	396,62
	1		0,12	1,19	11,90	118,99	1 189,86

log P <sub>ow</sub>	S <sub>w</sub> (mg/l)	LOD (micrograms/l)→	0,001	0,01	0,10	1,00	10
4,5	5		0,02	0,20	2,03	20,34	203,37
	2		0,05	0,51	5,08	50,84	508,42
	1		0,10	1,02	10,17	101,68	1 016,83
	0,5		0,20	2,03	20,34	203,37	2 033,67
5	1		0,09	0,87	8,69	86,90	869,01
	0,5		0,17	1,74	17,38	173,80	1 738,02
	0,375		0,23	2,32	23,18	231,75	2 317,53
	0,2		0,43	4,35	43,45	434,51	4 345,05
5,5	0,4		0,19	1,86	18,57	185,68	1 856,79
	0,2		0,37	3,71	37,14	371,36	3 713,59
	0,1		0,74	7,43	74,27	742,72	7 427,17
	0,05		1,49	14,85	148,54	1 485,43	14 854,35
6	0,1		0,63	6,35	63,48	634,80	6 347,95
	0,05		1,27	12,70	126,96	1 269,59	12 695,91
	0,025		2,54	25,39	253,92	2 539,18	25 391,82
	0,0125		5,08	50,78	507,84	5 078,36	50 783,64
6,5	0,025		2,17	21,70	217,02	2 170,25	21 702,46
	0,0125		4,34	43,40	434,05	4 340,49	43 404,93
	0,006		9,04	90,43	904,27	9 042,69	90 426,93
	0,003		18,09	180,85	1 808,54	18 085,39	180 853,86
7	0,006		7,73	77,29	772,89	7 728,85	77 288,50
	0,003		15,46	154,58	1 545,77	15 457,70	154 577,01
	0,0015		23,19	231,87	2 318,66	23 186,55	231 865,51
	0,001		46,37	463,73	4 637,31	46 373,10	463 731,03
7,5	0,002		19,82	198,18	1 981,77	19 817,73	198 177,33
	0,001		39,64	396,35	3 963,55	39 635,47	396 354,66
	0,0005		79,27	792,71	7 927,09	79 270,93	792 709,32
	0,00025		158,54	1 585,42	15 854,19	158 541,86	1 585 418,63
8	0,001		33,88	338,77	3 387,68	33 876,77	338 767,72
	0,0005		67,75	677,54	6 775,35	67 753,54	677 535,44
	0,00025		135,51	1 355,07	13 550,71	135 507,09	1 355 070,89
	0,000125		271,01	2 710,14	27 101,42	271 014,18	2 710 141,77
Volume used for LOD (l)		0,1					

## Appendix 2

**An example of glass-jacketed test vessel for the slow-stirring experiment for determination of  $P_{OW}$** 

(3) Chapter B.2 is replaced by the following:

**B.2. ACUTE INHALATION TOXICITY**

## INTRODUCTION

1. This Test Method is equivalent to OECD Test Guideline 403 (2009) (1). The original acute inhalation Test Guideline 403 (TG 403) was adopted in 1981. This revised Test Method B.2 (as equivalent to the revised TG 403) has been designed to be more flexible, to reduce animal usage, and to fulfil regulatory needs. The revised Test Method features two study types: a Traditional  $LC_{50}$  protocol and a Concentration  $\times$  Time ( $C \times t$ ) protocol. Primary features of this Test Method are the ability to provide a concentration-response relationship ranging from non-lethal to lethal outcomes in order to derive a median lethal concentration ( $LC_{50}$ ), non-lethal threshold concentration (e.g.  $LC_{01}$ ), and slope, and to identify possible sex susceptibility. The  $C \times t$  protocol should be used when there is a specific regulatory or scientific need that calls for the testing of animals over multiple time durations, such as for purposes of emergency response planning [e.g. deriving Acute Exposure Guideline Levels (AEGL), Emergency Response Planning Guidelines (ERPG), or Acute Exposure Threshold Levels (AETL) values], or for land-use planning.
2. Guidance on the conduct and interpretation of this Test Method studies can be found in the Guidance Document on Acute Inhalation Toxicity Testing (GD 39) (2).
3. Definitions used in the context of this Test Method are provided at the end of this chapter and in GD 39 (2).
4. This Test Method enables test chemical characterisation and quantitative risk assessment, and allows test chemicals to be ranked and classified according to Regulation (EC) No 1272/2008 (3). GD 39 (2) provides guidance in the selection of the appropriate Test Method for acute testing. When information on classification and labelling only is required, chapter B.52 of this Annex (4) is generally recommended [see GD 39 (2)]. This Test Method B.2 is not specifically intended for the testing of specialised materials, such as poorly soluble isometric or fibrous materials or manufactured nanomaterials.



#### INITIAL CONSIDERATIONS

5. Before considering testing in accordance with this Test Method all available information on the test chemical, including existing studies (e.g. chapter B.52 of this Annex (4)) whose data would support not doing additional testing should be considered by the testing laboratory in order to minimise animal usage. Information that may assist in the selection of the most appropriate species, strain, sex, mode of exposure and appropriate test concentrations include the identity, chemical structure, and physico-chemical properties of the test chemical; results of any *in vitro* or *in vivo* toxicity tests; anticipated uses and potential for human exposure; available (Q)SAR data and toxicological data on structurally related substances [see GD 39 (2)].
6. Testing corrosive and/or irritating test chemicals at concentrations that are expected to cause severe pain and/or distress should be avoided to the extent possible. The corrosive/irritating potential should be evaluated by expert judgment using such evidence as human and animal experience (e.g. from repeat dose studies performed at non-corrosive/irritant concentrations), existing *in vitro* data (e.g. from chapters B.40, (5), B.40bis (6) of this Annex or OECD TG 435 (7)), pH values, information from similar substances or any other pertinent data, for the purpose of investigating whether further testing can be waived. For specific regulatory needs (e.g. for emergency planning purposes), this Test Method may be used for exposing animals to these materials because it provides the study director or principal investigator with control over the selection of target concentrations. However, the targeted concentrations should not induce severe irritation/corrosive effects, yet sufficient to extend the concentration-response curve to levels that reach the regulatory and scientific objective of the test. These concentrations should be selected on a case-by-case basis and justification for concentration selection should be provided [see GD 39 (2)].

#### PRINCIPLE OF THE TEST

7. This revised Test Method B.2 has been designed to obtain sufficient information on the acute toxicity of a test chemical to enable its classification and to provide lethality data (e.g. LC<sub>50</sub>, LC<sub>01</sub> and slope) for one or both sexes as needed for quantitative risk assessments. This Test Method offers two methods. The first method is a traditional protocol in which groups of animals are exposed to a limit concentration (limit test) or a series of concentrations in a stepwise procedure for a predetermined duration of usually 4 hours. Other durations of exposure may apply to serve specific regulatory purposes. The second method is a (C × t) protocol in which groups of animals are exposed to one (limit concentration) or a series of multiple concentrations over multiple durations.
8. Moribund animals or animals obviously in pain or showing signs of severe and enduring distress should be humanely killed and are considered in the interpretation of the test result in the same way as animals that died on test. Criteria for making the decision to kill moribund or severely suffering animals, and guidance on the recognition of predictable or impending death, are the subject of an OECD Guidance Document No 19 on Humane Endpoints (8).

#### DESCRIPTION OF THE METHOD

##### **Selection of animal species**

9. Healthy young adult animals of commonly used laboratory strains should be used. The preferred species is the rat and justification should be provided if other species are used.

##### **Preparation of animals**

10. Females should be nulliparous and non-pregnant. On the exposure day, animals should be young adults 8 to 12 weeks of age, and body weights should be within ± 20 % of the mean weight for each sex of any previously exposed animals of the same age. The animals are randomly selected and marked for individual identification. The animals are kept in their cages for at least 5 days prior to the start of the test to allow for acclimatisation to laboratory conditions. Animals should also be acclimatised to the test apparatus for a short period prior to testing, as this will lessen the stress caused by introduction to the new environment.

##### **Animal husbandry**

11. The temperature of the experimental animal maintenance room should be 22 ± 3 °C. The relative humidity should ideally be maintained in the range of 30 to 70 %, though this may not be possible when using water as a vehicle. Before and after exposures, animals generally should be caged in groups by sex and concentration, but the number of animals per cage should not interfere with clear observation of each animal and should minimise losses due to cannibalism and fighting. When animals are to be exposed nose-only, it may be necessary for them to be acclimated to the restraining tubes. The restraining tubes should not impose undue physical, thermal, or immobilisation stress on the animals. Restraint may affect physiological endpoints such as body temperature (hyperthermia) and/or respiratory minute volume. If generic data are available to show that no such changes occur to any appreciable extent, then pre-adaptation to the restraining tubes is not necessary. Animals exposed whole-body to an aerosol should be housed individually during exposure to prevent them from

filtering the test aerosol through the fur of their cage mates. Conventional and certified laboratory diets may be used, except during exposure, accompanied with an unlimited supply of municipal drinking water. Lighting should be artificial, the sequence being 12 hours light/12 hours dark.

#### **Inhalation chambers**

12. The nature of the test chemical and the objective of the test should be considered when selecting an inhalation chamber. The preferred mode of exposure is nose-only (which term includes head-only, nose-only or snout-only). Nose-only exposure is generally preferred for studies of liquid or solid aerosols and for vapours that may condense to form aerosols. Special objectives of the study may be better achieved by using a whole-body mode of exposure, but this should be justified in the study report. To ensure atmosphere stability when using a whole-body chamber, the total volume of the test animals should not exceed 5 % of the chamber volume. Principles of the nose-only and whole body exposure techniques and their particular advantages and disadvantages are described in GD 39 (2).

#### **EXPOSURE CONDITIONS**

##### **Administration of concentrations**

13. Nose-only exposures may be any duration up to 6 hours in rats. If mice are exposed nose-only, exposures generally should not exceed 4 hours. Justification should be provided if longer duration studies are needed [see GD 39 (2)]. Animals exposed to aerosols in whole-body chambers should be housed individually to prevent ingestion of test chemical due to grooming of cage mates. Feed should be withheld during the exposure period. Water may be provided throughout a whole-body exposure.
14. Animals are exposed to the test chemical as a gas, vapour, aerosol, or a mixture thereof. The physical state to be tested depends on the physico-chemical properties of the test chemical, the selected concentration, and/or the physical form most likely present during the handling and use of the test chemical. Hygroscopic and chemically reactive test chemicals should be tested under dry air conditions. Care should be taken to avoid generating explosive concentrations.

##### **Particle-size distribution**

15. Particle sizing should be performed for all aerosols and for vapours that may condense to form aerosols. To allow for exposure of all relevant regions of the respiratory tract, aerosols with mass median aerodynamic diameters (MMAD) ranging from 1 to 4  $\mu\text{m}$  with a geometric standard deviation ( $\sigma_g$ ) in the range of 1,5 to 3,0 are recommended (2) (9) (10). Although a reasonable effort should be made to meet this standard, expert judgment should be provided if it cannot be achieved. For example, metal fumes may be smaller than this standard, and charged particles, fibres, and hygroscopic materials (which increase in size in the moist environment of the respiratory tract) may exceed this standard.

##### **Test chemical preparation in a vehicle**

16. A vehicle may be used to generate an appropriate concentration and particle size of the test chemical in the atmosphere. As a rule, water should be given preference. Particulate material may be subjected to mechanical processes to achieve the required particle size distribution, however, care should be taken to not decompose or alter the test chemical. In cases where mechanical processes are believed to have altered test chemical composition (e.g. extreme temperatures from excessive milling due to friction), the composition of the test chemical should be verified analytically. Adequate care should be taken to not contaminate the test chemical. It is not necessary to test non-friable granular materials which are purposefully formulated to be un-inhalable. An attrition test should be used to demonstrate that respirable particles are not produced when the granular material is handled. If an attrition test produces respirable substances, an inhalation toxicity test should be performed.

##### **Control animals**

17. A concurrent negative (air) control group is not necessary. When a vehicle other than water is used to assist in generating the test atmosphere, a vehicle control group should only be used when historical inhalation toxicity data are not available. If a toxicity study of a test chemical formulated in a vehicle reveals no toxicity, it follows that the vehicle is non-toxic at the concentration tested; thus, there is no need for a vehicle control.

#### **MONITORING OF EXPOSURE CONDITIONS**

##### **Chamber airflow**

18. The flow of air through the chamber should be carefully controlled, continuously monitored, and recorded at least hourly during each exposure. The monitoring of test atmosphere concentration (or stability) is an integral

measurement of all dynamic parameters and provides an indirect means to control all relevant dynamic atmosphere generation parameters. Special consideration should be given to avoiding re-breathing in nose-only chambers in cases where airflow through the exposure system are inadequate to provide dynamic flow of test chemical atmosphere. There are prescribed methodologies that can be used to demonstrate that re-breathing does not occur under the selected operation conditions (2) (11). Oxygen concentration should be at least 19 % and carbon dioxide concentration should not exceed 1 %. If there is reason to believe that these standards cannot be met, oxygen and carbon dioxide concentrations should be measured.

#### **Chamber temperature and relative humidity**

19. Chamber temperature should be maintained at  $22 \pm 3$  °C. Relative humidity in the animals' breathing zone, for both nose-only and whole-body exposures, should be monitored and recorded at least three times for durations of up to 4 hrs, and hourly for shorter durations. The relative humidity should ideally be maintained in the range of 30 to 70 %, but this may either be unattainable (e.g. when testing water based mixtures) or not measurable due to test chemical interference with the test method.

#### **Test chemical: Nominal concentration**

20. Whenever feasible, the nominal exposure chamber concentration should be calculated and recorded. The nominal concentration is the mass of generated test chemical divided by the total volume of air passed through the chamber system. The nominal concentration is not used to characterise the animals' exposure, but a comparison of the nominal concentration and the actual concentration gives an indication of the generation efficiency of the test system, and thus may be used to discover generation problems.

#### **Test chemical: Actual concentration**

21. The actual concentration is the test chemical concentration at the animals' breathing zone in an inhalation chamber. Actual concentrations can be obtained by specific methods (e.g. direct sampling, adsorptive or chemical reactive methods, and subsequent analytical characterisation) or by non-specific methods such as gravimetric filter analysis. The use of gravimetric analysis is acceptable only for single component powder aerosols or aerosols of low volatility liquids and should be supported by appropriate pre-study test chemical-specific characterisations. Multi-component powder aerosol concentration may also be determined by gravimetric analysis. However, this requires analytical data which demonstrate that the composition of airborne material is similar to the starting material. If this information is not available, a reanalysis of the test chemical (ideally in its airborne state) at regular intervals during the course of the study may be necessary. For aerosolised agents that may evaporate or sublime, it should be shown that all phases were collected by the method chosen. The target, nominal, and actual concentrations should be provided in the study report, but only actual concentrations are used in statistical analyses to calculate lethal concentration values.
22. One lot of the test chemical should be used, if possible, and the test sample should be stored under conditions that maintain its purity, homogeneity, and stability. Prior to the start of the study, there should be a characterisation of the test chemical, including its purity and, if technically feasible, the identity, and quantities of identified contaminants and impurities. This can be demonstrated by, but is not limited to, the following data: retention time and relative peak area, molecular weight from mass spectroscopy or gas chromatography analyses, or other estimates. Although the test sample's identity is not the responsibility of the test laboratory, it may be prudent for the test laboratory to confirm the sponsor's characterisation at least in a limited way (e.g. colour, physical nature, etc.).
23. The exposure atmosphere shall be held as constant as practicable and monitored continuously and/or intermittently depending on the method of analysis. When intermittent sampling is used, chamber atmosphere samples should be taken at least twice in a four hour study. If not feasible due to limited air flow rates or low concentrations, one sample may be collected over the entire exposure period. If marked sample-to-sample fluctuations occur, the next concentrations tested should use four samples per exposure. Individual chamber concentration samples should not deviate from the mean concentration by more than  $\pm 10$  % for gases and vapours or  $\pm 20$  % for liquid or solid aerosols. Time to chamber equilibration ( $t_{95}$ ) should be calculated and recorded. The duration of an exposure spans the time that the test chemical is generated and this takes into account the times required to attain  $t_{95}$ . Guidance for estimating  $t_{95}$  can be found in GD 39 (2).
24. For very complex mixtures consisting of gases/vapours, and aerosols (e.g. combustion atmospheres and test chemicals propelled from purpose-driven end-use products/devices), each phase may behave differently in an inhalation chamber so at least one indicator substance (analyte), normally the principal active substance in the mixture, of each phase (gas/vapour and aerosol) should be selected. When the test chemical is a mixture, the analytical concentration should be reported for the mixture and not just for the active substance or the component (analyte). Additional information regarding actual concentrations can be found in GD 39 (2).

**Test chemical: Particle size distribution**

25. The particle size distribution of aerosols should be determined at least twice during each 4 hour exposure by using a cascade impactor or an alternative instrument such as an aerodynamic particle sizer. If equivalence of the results obtained by a cascade impactor or an alternative instrument can be shown, then the alternative instrument may be used throughout the study. A second device, such as a gravimetric filter or an impinger/gas bubbler, should be used in parallel to the primary instrument to confirm the collection efficiency of the primary instrument. The mass concentration obtained by particle size analysis should be within reasonable limits of the mass concentration obtained by filter analysis [see GD 39 (2)]. If equivalence can be demonstrated in the early phase of the study, then further confirmatory measurements may be omitted. For animal welfare reasons, measures should be taken to minimise inconclusive data which may lead to a need to repeat an exposure. Particle sizing should be performed for vapours if there is any possibility that vapour condensation may result in the formation of an aerosol, or if particles are detected in a vapour atmosphere with potential for mixed phases (see paragraph 15).

**PROCEDURE**

26. Two study types are described below: the Traditional protocol, and the  $C \times t$  protocol. Both protocols may include a sighting study, a main study, and/or a limit test (Traditional protocol) or testing at a limit concentration ( $C \times t$ ). If one sex is known to be more susceptible, the study director may choose to perform these studies using only the susceptible sex. If rodent species other than rats are exposed nose-only, maximum exposure durations may be adjusted to minimise species-specific distress. Before commencing, all available data should be considered in order to minimise animal usage. For example, data generated using chapter B.52 of this Annex (4) may eliminate the need for a sighting study, and may also demonstrate whether one sex is more susceptible [see GD 39 (2)].

**TRADITIONAL PROTOCOL****General considerations: Traditional protocol**

27. In a Traditional study, groups of animals are exposed to a test chemical for a fixed period of time (generally 4 hours) in either a nose-only or whole-body exposure chamber. Animals are exposed to either a limit concentration (limit test), or to at least three concentrations in a stepwise procedure (main study). A sighting study may precede a main study unless some information about the test chemical already exists, such as a previously performed B.52 study [see GD 39 (2)].

**Sighting study: Traditional protocol**

28. A sighting study is used to estimate test chemical potency, identify sex differences in susceptibility, and assist in selecting exposure concentration levels for the main study or limit test. When selecting concentration levels for the sighting study, all available information should be used including available (Q)SAR data and data for similar chemicals. No more than three males and three females should be exposed at each concentration (3 animals/sex may be needed to establish a sex difference). A sighting study may consist of a single concentration, but more concentrations may be tested if necessary. A sighting study should not test so many animals and concentrations that it resembles a main study. A previously performed B.52 study (4) may be used instead of a sighting study [see GD 39 (2)].

**Limit test: Traditional protocol**

29. A limit test is used when the test chemical is known or expected to be virtually non-toxic, i.e. eliciting a toxic response only above the regulatory limit concentration. In a limit test, a single group of three males and three females is exposed to the test chemical at a limit concentration. Information about the toxicity of the test chemical can be gained from knowledge about similar tested chemicals, taking into consideration the identity and percentage of components known to be of toxicological significance. In those situations where there is little or no information about its toxicity, or the test chemical is expected to be toxic, the main test should be performed.
30. The selection of limit concentrations usually depends on regulatory requirements. When Regulation (EC) No 1272/2008 is used, the limit concentrations for gases, vapours, and aerosols are 20 000 ppm, 20 mg/l and 5 mg/l, respectively (or the maximum attainable concentration) (3). It can be technically challenging to generate limit concentrations of some test chemicals, especially as vapours and aerosols. When testing aerosols, the primary goal should be to achieve a respirable particle size (MMAD of 1-4  $\mu\text{m}$ ). This is possible with most test chemicals at a concentration of 2 mg/l. Aerosol testing at greater than 2 mg/l should only be attempted if a respirable particle size can be achieved [see GD 39 (2)]. Regulation (EC) No 1272/2008 discourages testing in excess of a limit concentration for animal welfare reasons (3). The limit concentration should only be considered when there is a strong likelihood that results of such a test would have direct relevance for protecting human health (3), and justification provided in the study report. In the case of potentially explosive test chemicals, care should be taken to avoid conditions favourable for an explosion. To avoid an unnecessary use of animals, a test run without animals should be conducted prior to the limit test to ensure that the chamber conditions for a limit test can be achieved.

31. If mortality or moribundity is observed at the limit concentration, the results of the limit test can serve as a sighting study for further testing at other concentrations (see main study). If a test chemical's physical or chemical properties make it impossible to attain a limit concentration, the maximum attainable concentration should be tested. If less than 50 % lethality occurs at the maximum attainable concentration, no further testing is necessary. If the limit concentration could not be attained, the study report should provide an explanation and supportive data. If the maximum attainable concentration of a vapour does not elicit toxicity, it may be necessary to generate the test chemical as a liquid aerosol.

#### **Main study: Traditional protocol**

32. A main study is typically performed using five males and five females (or 5 animals of the susceptible sex, if known) per concentration level, with at least three concentration levels. Sufficient concentration levels should be used to obtain a robust statistical analysis. The time interval between exposure groups is determined by the onset, duration, and severity of toxic signs. Exposure of animals at the next concentration level should be delayed until there is reasonable confidence of survival for previously tested animals. This allows the study director to adjust the target concentration for the next exposure group. Due to the dependence on sophisticated technologies, this may not always be practical in inhalation studies, so the exposure of animals at the next concentration level should be based on previous experience and scientific judgement. GD 39 (2) should be consulted when testing mixtures.

#### **CONCENTRATION × TIME (C × T) PROTOCOL**

##### **General considerations: C × t protocol**

33. A step-wise C × t study may be considered as an alternative to a Traditional protocol when assessing inhalation toxicity (12) (13) (14). This approach allows animals to be exposed to a test chemical at several concentration levels and for multiple time durations. All testing is performed in a nose-only chamber (whole-body chambers are not practical for this protocol). A flow diagram in Appendix 1 illustrates this protocol. A simulation analysis has shown that the Traditional protocol and the C × t protocol are both capable of yielding robust LC<sub>50</sub> values, but the C × t protocol is generally better at yielding robust LC<sub>01</sub> and LC<sub>10</sub> values (15).
34. A simulation analysis has demonstrated that using two animals per C × t interval (one per sex using both sexes, or two of the more susceptible sex) may generally be adequate when testing 4 concentrations and 5 exposure durations in a main study. Under some circumstances, the study director may elect to use two rats per sex per C × t interval (15). Using 2 animals per sex per concentration and time point may reduce bias and variability of the estimates, increase the estimation success rate, and improve confidence interval coverage. However, in case of an insufficient close fit to the data for estimation (when using one animal per sex or two animals of the more susceptible sex) a 5th exposure concentration may also suffice. Further guidance on the number of animals and concentrations to be used in a C × t study can be found in GD 39 (2).

##### **Sighting study: C × t protocol**

35. A sighting study is used to estimate test chemical potency and to assist in selecting exposure concentration levels for the main study. A sighting study using up to three animals/sex/concentration [for details see Appendix III of GD 39 (2)] may be needed to choose an appropriate starting concentration for the main study and to minimise the number of animals used. It may be necessary to use three animals per sex to establish a sex difference. These animals should be exposed for a single duration, generally 240 min. The feasibility of generating adequate test atmospheres should be assessed during technical pre-tests without animals. It is generally not necessary to perform a sighting study if mortality data are available from a B.52 study (4). When selecting the initial target concentration in a B.2 study, the study director should consider the mortality patterns observed in any available B.52 studies (4) for both sexes and for all concentrations tested [see GD 39 (2)].

##### **Initial Concentration: C × t protocol**

36. The initial concentration (Exposure Session I) (Appendix 1) will either be a limit concentration or a concentration selected by the study director based on the sighting study. Groups of 1 animal/sex are exposed to this concentration for multiple durations (e.g. 15, 30, 60, 120, or 240 minutes), resulting in a total number of 10 animals (called Exposure Session I) (Appendix 1).
37. The selection of limit concentrations usually depends on regulatory requirements. When Regulation (EC) No 1272/2008 is used, the limit concentrations for gases, vapours, and aerosols are 20 000 ppm, 20 mg/l and 5 mg/l, respectively (or the maximum attainable concentration) (3). It can be technically challenging to generate limit concentrations of some test chemicals, especially as vapours and aerosols. When testing aerosols, the goal should be to achieve a respirable particle size (i.e. an MMAD of 1-4 µm) at a limit concentration of 2 mg/l. This is possible with most test chemicals. Aerosol testing at greater than 2 mg/l should only be attempted if a respirable particle size can be achieved [see GD 39 (2)]. Regulation (EC) No 1272/2008 discourages testing in excess of a limit concentration for animal welfare reasons (3). Testing in excess of the limit concentration should only be considered when there is a strong likelihood that results of such a test would



have direct relevance for protecting human health (3), justification should be provided in the study report. In the case of potentially explosive test chemicals, care should be taken to avoid conditions favourable for an explosion. To avoid an unnecessary use of animals, a test run without animals should be conducted prior to testing at the initial concentration to ensure that the chamber conditions for this concentration can be achieved.

38. If mortality or moribundity is observed at the initial concentration, the results at this concentration can serve as a starting point for further testing at other concentrations (see main study). When a test chemical's physical or chemical properties make it impossible to attain a limit concentration, the maximum attainable concentration should be tested. If less than 50 % lethality occurs at the maximum attainable concentration, no further testing is necessary. If the limit concentration could not be attained, the study report should provide an explanation and supportive data. If the maximum attainable concentration of a vapour does not elicit toxicity, it may be necessary to generate the test chemical as a liquid aerosol.

#### **Main study: C × t protocol**

39. The initial concentration (Exposure Session I) (Appendix 1) tested in the main study will either be a limit concentration or a concentration selected by the study director based on the sighting study. If mortality has been observed during or following Exposure Session I, the minimum exposure (C × t) which results in mortality will be taken as a guide to establish the concentration and periods of exposure for Exposure Session II. Each subsequent exposure session will depend on the previous session (see Appendix 1).
40. For many test chemicals the results obtained at the initial concentration, together with three additional exposure sessions with a smaller time grid (i.e. the geometric spacing of exposure periods as indicated by the factor between successive periods, generally  $\sqrt{2}$ ), will be sufficient to establish the C × t mortality relationship (15), but there may be some benefit to using a 5th exposure concentration [see Appendix 1 and GD 39 (2)]. For mathematical treatment of results for the C × t protocol, see Appendix 1.

#### **OBSERVATIONS**

41. The animals should be clinically observed frequently during the exposure period. Following exposure, clinical observations should be made at least twice on the day of exposure, or more frequently when indicated by the response of the animals to treatment, and at least once daily thereafter for a total of 14 days. The length of the observation period is not fixed, but should be determined by the nature and time of onset of clinical signs and length of the recovery period. The times at which signs of toxicity appear and disappear are important, especially if there is a tendency for signs of toxicity to be delayed. All observations are systematically recorded with individual records being maintained for each animal. Animals found in a moribund condition and animals showing severe pain and/or enduring signs of severe distress should be humanely killed for animal welfare reasons. Care should be taken when conducting examinations for clinical signs of toxicity that initial poor appearance and transient respiratory changes, resulting from the exposure procedure, are not mistaken for test chemical-related toxicity that would require premature killing of the animals. The principles and criteria summarised in the Guidance Document on Humane Endpoints (GD 19) should be taken into consideration (7). When animals are killed for humane reasons or found dead, the time of death should be recorded as precisely as possible.
42. Cage-side observations should include changes in the skin and fur, eyes and mucous membranes, and also respiratory, circulatory, autonomic and central nervous systems, and somatomotor activity and behaviour patterns. When possible, any differentiation between local and systemic effects should be noted. Attention should be directed to observations of tremors, convulsions, salivation, diarrhoea, lethargy, sleep and coma. The measurement of rectal temperature may provide supportive evidence of reflex bradypnea or hypo/hyperthermia related to treatment or confinement.

#### **Body weights**

43. Individual animal weights should be recorded once during the acclimatization period, on the day of exposure prior to exposure (day 0), and at least on days 1, 3 and 7 (and weekly thereafter), and at the time of death or euthanasia if exceeding day 1. Body weight is recognised as a critical indicator of toxicity so animals exhibiting a sustained decrement of  $\geq 20\%$ , compared to pre-study values, should be closely monitored. Surviving animals are weighed and humanely killed at the end of the post-exposure period.

#### **Pathology**

44. All test animals, including those which die during the test or are euthanised and removed from the study for animal welfare reasons, should be subjected to gross necropsy. If necropsy cannot be performed immediately after a dead animal is discovered, the animal should be refrigerated (not frozen) at temperatures low enough to minimise autolysis. Necropsies should be performed as soon as possible, normally within a day or two. All gross pathological changes should be recorded for each animal with particular attention to any changes in the respiratory tract.

45. Additional examinations included a priori by design may be considered to extend the interpretive value of the study, such as measuring lung weight of surviving rats, and/or providing evidence of irritation by microscopic examination of the respiratory tract. Examined organs may also include those showing evidence of gross pathology in animals surviving 24 or more hours, and organs known or expected to be affected. Microscopic examination of the entire respiratory tract may provide useful information for test chemicals that are reactive with water, such as acids and hygroscopic test chemicals.

#### DATA AND REPORTING

##### **Data**

46. Individual animal data on body weights and necropsy findings should be provided. Clinical observation data should be summarised in tabular form, showing for each test group the number of animals used, the number of animals displaying specific signs of toxicity, the number of animals found dead during the test or killed for humane reasons, time of death of individual animals, a description and time course of toxic effects and reversibility, and necropsy findings.

##### **Test report**

47. The test report should include the following information, as appropriate:

##### *Test animals and husbandry*

- Description of caging conditions, including: number (or change in number) of animals per cage, bedding material, ambient temperature and relative humidity, photoperiod, and identification of diet
- Species/strain used and justification for using a species other than the rat
- Number, age and sex of animals
- Method of randomisation
- Details of food and water quality (including diet type/source, water source)
- Description of any pre-test conditioning including diet, quarantine, and treatment for disease;

##### *Test chemical*

- Physical nature, purity and, where relevant, physico-chemical properties (including isomerisation)
- Identification data and Chemical Abstract Services (CAS) Registry Number, if known;

##### *Vehicle*

- Justification for use of vehicle and justification for choice of vehicle (if other than water)
- Historical or concurrent data demonstrating that the vehicle does not interfere with the outcome of the study;

##### *Inhalation chamber*

- Description of the inhalation chamber including dimensions and volume
- Source and description of equipment used for the exposure of animals as well as generation of atmosphere
- Equipment for measuring temperature, humidity, particle-size, and actual concentration

- Source of air and treatment of air supplied/extracted and system used for conditioning
- Methods used for calibration of equipment to ensure a homogeneous test atmosphere
- Pressure difference (positive or negative)
- Exposure ports per chamber (nose-only); location of animals in the system (whole-body)
- Temporal homogeneity/stability of test atmosphere
- Location of temperature and humidity sensors and sampling of test atmosphere in the chamber
- Air flow rates, air flow rate/exposure port (nose-only), or animal load/chamber (whole-body)
- Information about the equipment used to measure oxygen and carbon dioxide, if applicable
- Time required to reach inhalation chamber equilibrium ( $t_{95}$ )
- Number of volume changes per hour
- Metering devices (if applicable);

#### *Exposure data*

- Rationale for target concentration selection in the main study
- Nominal concentrations (total mass of test chemical generated into the inhalation chamber divided by the volume of air passed through the chamber)
- Actual test chemical concentrations collected from the animals' breathing zone; for mixtures that produce heterogeneous physical forms (gases, vapours, aerosols), each may be analysed separately
- All air concentrations should be reported in units of mass (e.g. mg/l, mg/m<sup>3</sup>, etc.); units of volume (e.g. ppm, ppb, etc.) may also be reported parenthetically
- Particle size distribution, mass median aerodynamic diameter (MMAD), and geometric standard deviation ( $\sigma_g$ ), including their methods of calculation. Individual particle size analyses should be reported;

#### *Test conditions*

- Details of test chemical preparation, including details of any procedures used to reduce the particle size of solid materials or to prepare solutions of the test chemical. In cases where mechanical processes may have altered test chemical composition, include the results of analyses to verify the composition of the test chemical
- A description (preferably including a diagram) of the equipment used to generate the test atmosphere and to expose the animals to the test atmosphere
- Details of the chemical analytical method used and method validation (including efficiency of recovery of test chemical from the sampling medium)
- The rationale for the selection of test concentrations;



*Results*

- Tabulation of chamber temperature, humidity, and airflow
- Tabulation of chamber nominal and actual concentration data
- Tabulation of particle size data including analytical sample collection data, particle size distribution and calculations of the MMAD and  $\sigma_g$
- Tabulation of response data and concentration level for each animal (i.e. animals showing signs of toxicity including mortality, nature, severity, time of onset and duration of effects)
- Individual body weights of animals collected on study; date and time of death if prior to scheduled euthanasia, time course of onset of signs of toxicity and whether these were reversible for each animal
- Necropsy findings and histopathological findings for each animal, if available
- Lethality estimates (e.g. LC<sub>50</sub>, LD<sub>01</sub>) including 95 % confidence limits, and slope (if provided by the evaluation method)
- Statistical relation, including estimate for the exponent n (C × t protocol). The name of the statistical software used should be provided;

*Discussion and interpretation of results*

- Particular emphasis should be made to the description of methods used to meet this Test Method's criteria, e.g. the limit concentration or the particle size
- The respirability of particles in light of the overall findings should be addressed, especially if the particle-size criteria could not be met
- An explanation should be provided if there was a need to humanely sacrifice animals in pain or showing signs of severe and enduring distress, based on the criteria in the OECD Guidance Document on Humane Endpoints (8)
- If testing with chapter B.52 of this Annex (4) was discontinued in favour of this Test Method B.2, justifications should be provided
- The consistency of methods used to determine nominal and actual concentrations, and the relation of actual concentration to nominal concentration should be included in the overall assessment of the study
- The likely cause of death and predominant mode of action (systemic versus local) should be addressed.

*LITERATURE:*

- (1) OECD (2009). Acute Inhalation Toxicity Testing. OECD Guideline for Testing of Chemicals No 403, OECD, Paris. Available at: [<http://www.oecd.org/env/testguidelines>]
- (2) OECD (2009). Guidance Document on Acute Inhalation Toxicity Testing. Environmental Health and Safety Monograph Series on Testing and Assessment No 39, OECD, Paris. Available at: [<http://www.oecd.org/env/testguidelines>]
- (3) Regulation (EC) No 1272/2008 of the European Parliament and of the Council of 16 December 2008 on classification, labelling and packaging of substances and mixtures, amending and repealing Directives 67/548/EEC and 1999/45/EC and amending Regulation (EC) No 1907/2006 (OJ L 353, 31.12.2008, p. 1).
- (4) Chapter B.52 of this Annex, Acute Inhalation Toxicity — Acute Toxic Class (ATC) Method.

- (5) Chapter B.40 of this Annex, In Vitro Skin Corrosion: Transcutaneous Electrical Resistance Test (TER).
- (6) Chapter B.40bis of this Annex, In Vitro Skin Corrosion: Human Skin Model Test.
- (7) OECD (2005), In Vitro Membrane Barrier Test Method For Skin Corrosion. OECD Guideline for Testing of Chemicals No 435, OECD, Paris. Available at: [<http://www.oecd.org/env/testguidelines>]
- (8) OECD (2000). Guidance Document on the Recognition, Assessment and Use of Clinical Signs as Humane Endpoints for Experimental Animals Used in Safety Evaluation. Environmental Health and Safety Monograph Series on Testing and Assessment No 19, OECD, Paris. Available at: [<http://www.oecd.org/env/testguidelines>]
- (9) SOT (1992). Technical Committee of the Inhalation Specialty Section, Society of Toxicology (SOT). Recommendations for the Conduct of Acute Inhalation Limit Tests. *Fund. Appl. Toxicol.* 18: 321-327.
- (10) Phalen RF (2009). *Inhalation Studies: Foundations and Techniques*. (2nd Edition) Informa Healthcare, New York.
- (11) Pauluhn J and Thiel A (2007). A Simple Approach to Validation of Directed-Flow Nose-Only Inhalation Chambers. *J. Appl. Toxicol.* 27: 160-167.
- (12) Zwart JHE, Arts JM, ten Berge WF, Appelman LM (1992). Alternative Acute Inhalation Toxicity Testing by Determination of the Concentration-Time-Mortality Relationship: Experimental Comparison with Standard LC50 Testing. *Reg. Toxicol. Pharmacol.* 15: 278-290.
- (13) Zwart JHE, Arts JM, Klokman-Houweling ED, Schoen ED (1990). Determination of Concentration-Time-Mortality Relationships to Replace LC50 Values. *Inhal. Toxicol.* 2: 105-117.
- (14) Ten Berge WF and Zwart A (1989). More Efficient Use of Animals in Acute Inhalation Toxicity Testing. *J. Haz. Mat.* 21: 65-71.
- (15) OECD (2009). Performance Assessment: Comparison of 403 and C × t Protocols via Simulation and for Selected Real Data Sets. Environmental Health and Safety Monograph Series on Testing and Assessment No 104, OECD, Paris. Available at: [<http://www.oecd.org/env/testguidelines>]
- (16) Finney DJ (1977). *Probit Analysis*, 3rd ed. Cambridge University Press, London/New York.

#### DEFINITION

**Test chemical:** Any substance or mixture tested using this Test Method.

---

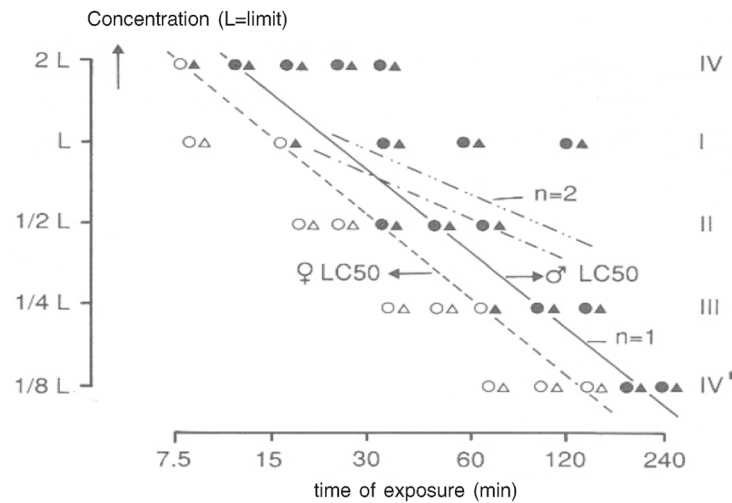
## Appendix 1

**C × t Protocol**

1. A step-wise Concentration × Time (C × t) study may be considered as an alternative to the Traditional protocol for assessing inhalation toxicity (12) (13) (14). It should be performed preferentially when there is a specific regulatory or scientific need that calls for the testing of animals over multiple time durations such as for emergency response planning or land use planning. This approach usually begins with testing at a limit concentration (Exposure Session I) in which animals are exposed to a test chemical for five time durations (e.g. 15, 30, 60, 120 and 240 min) so that multiple durations of time will be obtained within one exposure session (see Figure 1). When Regulation (EC) No 1272/2008 is used, the limit concentrations for gases, vapours, and aerosols are 20 000 ppm, 20 mg/l, and 5 mg/l, respectively. These levels may only be exceeded if there is a regulatory or scientific need for testing at these levels (see paragraph 37 in the B.2 main text).
2. In situations where there is little or no information about the toxicity of a test chemical, a sighting study should be performed in which groups of no more than 3 animals per sex are exposed to target concentrations selected by the study director, generally for 240 min.
3. If a limit concentration is tested during Exposure Session I and less than 50 % mortality is observed, no additional testing is needed. If there is a regulatory or scientific need to establish the concentration/time/response relationship at higher levels than the indicated limit concentration, the next exposure should be carried out at a higher level such as at two times the limit concentration (i.e. 2L in Figure 1).
4. If toxicity is observed at the limit concentration, additional testing (main study) is necessary. These additional exposures are carried out either at lower concentrations (in Figure 1: Exposure Sessions II, III or IV) or at higher concentrations using shorter durations (in Figure 1: Exposure Session IV) using durations that are adapted and not as widely spaced.
5. The test (initial concentration and additional concentrations) is carried out using 1 animal/sex per concentration/time point or with 2 animals of the more susceptible sex per concentration/time point. Under some circumstances, the study director may elect to utilise 2 rats per sex per concentration/time point (or 4 animals of the susceptible sex per concentration/time point) (15). Using 2 animals per sex per concentration/time point generally reduces bias and variability of the estimates, increases the estimation success rate, and improves confidence interval coverage relative to the protocol as described here. Further details are provided in GD 39 (2).
6. Ideally, each exposure session is carried out on one day. This gives the opportunity to delay the next exposure until there is reasonable confidence of survival, and it allows the study director to adjust the target concentration and durations for the next exposure session. It is advised to start each exposure session with the group that will be exposed the longest, e.g. the 240-min exposure group, followed by the 120 minute exposure group, and so on. If, for example, animals in the 240 minute group are dying after 90 minutes or showing severe signs of toxicity (e.g. extreme changes in breathing pattern such as laboured breathing), it would not make sense to expose a group for 120 minutes because mortality would likely be 100 %. Thus the study director should select shorter exposure durations for that concentration (e.g. 90, 65, 45, 33 and 25 minutes).
7. The chamber concentration should be measured frequently to determine the time-weighted-average concentration for each exposure duration. Whenever possible, the time of death for each animal (rather than the exposure duration) should be used in the statistical analysis.
8. The results of the first four exposure sessions should be examined to identify a data gap in the concentration-time curve (see Figure 1). In case of an insufficient fit, an additional exposure (5th concentration) may be performed. Concentration and exposure durations for the 5th exposure should be chosen to cover this gap.
9. All exposure sessions (including the first Exposure Session) will be used to calculate the concentration-time-response relationship using Statistical Analysis (16). If possible, for each C × t interval, the time-weighted average concentration and the duration of exposure until death (if death occurs during the exposure) should be used.

Figure 1

## Hypothetical illustration of a concentration-time-mortality relationship in rats



Open symbols = survivors; closed symbols = dead animals

Triangles = females; circles = males

Solid line = LC<sub>50</sub> values (range 7,5-240 min) for males with n = 1

Dashed line = LC<sub>50</sub> values (range 7,5-240 min) for females with n = 1

Dotted lines = hypothetical LC<sub>50</sub> values line for males and females if n had been equal to 2 (12).

Glossary

Concentration:

Time of exposure:

10. Below is an example of the stepwise procedure:

#### Exposure Session I — Testing at the limit concentration (see Figure 1)

- 1 animal/sex per concentration/time point; 10 animals in total <sup>(a)</sup>
- Target concentration <sup>(b)</sup> = limit concentration.
- Expose five groups of animals at this target concentration for durations of 15, 30, 60, 120 and 240 minutes, respectively.

↓

#### Exposure Session II <sup>(c)</sup> — Main Study

- 1 animal/sex per concentration/time point; 10 animals in total.

<sup>(a)</sup> If no sex susceptibility information is available, rats of both sexes will be used, *i.e.* 1 animal/sex per concentration. Based on existing information, or if it becomes apparent during this exposure session that one sex is more susceptible, 10 animals of the susceptible sex will be used (2 animals per concentration/time point) at each concentration level during subsequent testing.

<sup>(b)</sup> When Regulation (EC) No 1272/2008 is used, the limit concentrations for gases, vapours, and aerosols are 20 000 ppm, 20 mg/l, and 5 mg/l, respectively. In case of expected toxicity or based on the results of the sighting study, lower starting concentrations should be chosen. In case of regulatory or scientific needs, higher concentrations may be used.

<sup>(c)</sup> Ideally, exposure of animals at the next concentration level should be delayed until there is reasonable confidence of survival for previously treated animals. This allows the study director to adjust the target concentration and durations for the next exposure session.

- Expose five groups of animals at a lower concentration <sup>(d)</sup> (1/2L) with slightly longer exposure durations (factor  $\sqrt{2}$  spaced; see Figure 1).

↓

#### Exposure Session III — Main Study

- 1 animal/sex per concentration/time point; 10 animals total.
- Expose five groups of animals at a lower concentration <sup>(d)</sup> (1/4L) with slightly longer exposure durations (factor  $\sqrt{2}$  spaced; see Figure 1).

↓

#### Exposure Session IV' — Main Study

- 1 animal/sex per concentration/time point; 10 animals total.
- Expose five groups of animals at a lower concentration <sup>(d)</sup> (1/8L) with slightly longer exposure durations (factor  $\sqrt{2}$  spaced; see Figure 1).

↓ or

#### Exposure Session IV — Main Study

- 1 animal/sex per concentration/time point; 10 animals total.
- Expose five groups of animals at a higher concentration <sup>(e)</sup> (2L) with slightly shorter exposure durations (factor  $\sqrt{2}$  spaced; see Figure 1).

#### Mathematical treatment of results for the C × t protocol

11. A C × t procedure with 4 or 5 exposure concentrations and five durations will yield 20 or 25 data points, respectively. With these data points, the C × t relationship can be calculated using statistical analysis (16):

Equation 1:

$$\text{Probit}(P) = b_0 + b_1 \ln C + b_2 \ln t$$

where C = concentration; t = exposure duration, or

Equation 2:

$$\text{Response} = f(C^n t)$$

where  $n = b_1/b_2$ .

Using equation 1, the LC<sub>50</sub> value can be calculated for a given time period (e.g. 4 hour, 1 hour, 30 minutes, or any time period within the range of time periods tested) using P = 5 (50 % response). Note that Haber's rule is only applicable when n = 1. The LC<sub>01</sub> can be calculated using P = 2,67.

<sup>(d)</sup> The minimum dose (concentration x time) which resulted in mortality during testing at initial concentration (first exposure session) will be taken as a guide to establish the next combination of concentration and exposure durations. Typically, the concentration will be decreased two-fold (1/2L) and animals will be exposed over a new time range with a finer grid using a geometric division of exposure periods with a factor 1,4 ( $\sqrt{2}$ ; see reference 11) around the time according to the minimum lethal dose level (time x concentration) observed during the first exposure. In this figure (Figure 1), mortality in Exposure session I was first observed at 15 min; the durations during session II are therefore centred around 30 min, and are 15, 21, 30, 42 and 60 min. After the first two exposures, it is strongly advised to plot the data in a similar figure as indicated above, and to check whether the relationship between concentration and time has an angle of 45 degrees (n = 1) or if the concentration-time-response relationship is less steep (e.g. n = 2) or steeper (e.g. n = 0,8). In the latter cases it is strongly advised to adapt the next concentrations and durations accordingly.

<sup>(e)</sup> In certain cases it may be necessary to increase the concentration (2L) over a new time range with a still finer grid using a geometric division of exposure periods with a factor 1,4 ( $\sqrt{2}$ ) around the time according to the minimum lethal concentration level observed during the first exposure. The minimum exposure duration should preferably exceed 5 minutes; the maximum exposure duration should not exceed 8 hours.

- (4) Chapters B.7 and B.8 are replaced by the following:

#### **'B.7. REPEATED DOSE 28-DAY ORAL TOXICITY STUDY IN RODENTS**

##### INTRODUCTION

1. This Test Method is equivalent to OECD Test Guideline 407 (2008). The original Test Guideline 407 was adopted in 1981. In 1995 a revised version was adopted, to obtain additional information from the animal used in the study, in particular on neurotoxicity and immunotoxicity.
2. In 1998, the OECD initiated a high-priority activity, to revise existing Test Guidelines and to develop new Test Guidelines for the screening and testing of potential endocrine disruptors (8). One element of the activity was to update the existing OECD guideline for "repeated dose 28-day oral toxicity study in rodents" (TG 407) by parameters suitable to detect endocrine activity of test chemicals. This procedure underwent an extensive international program to test for the relevance and practicability of the additional parameters, the performance of these parameters for chemicals with (anti)oestrogenic, (anti)androgenic, and (anti)thyroid activity, the intra- and inter-laboratory reproducibility, and the interference of the new parameters with those required by the prior TG 407. The large amount of data thereby obtained has been compiled and evaluated in detail in a comprehensive OECD report (9). This updated Test Method B.7 (as equivalent to TG 407) is the outcome of the experience and results gained during the international test program. This Test Method allows certain endocrine mediated effects to be put into context with other toxicological effects.

##### INITIAL CONSIDERATIONS AND LIMITATIONS

3. In the assessment and evaluation of the toxic characteristics of a chemical, the determination of oral toxicity using repeated doses may be carried out after initial information on toxicity has been obtained by acute toxicity testing. This Test Method is intended to investigate effects on a very broad variety of potential targets of toxicity. It provides information on the possible health hazards likely to arise from repeated exposure over a relatively limited period of time, including effects on the nervous, immune and endocrine systems. Regarding these particular endpoints, it should identify chemicals with neurotoxic potential, which may warrant further in-depth investigation of this aspect, and chemicals that interfere with thyroid physiology. It may also provide data on chemicals that affect the male and/or female reproductive organs in young adult animals and may give an indication of immunological effects.
4. The results from this Test Method B.7 should be used for hazard identification and risk assessment. The results obtained by the endocrine related parameters should be seen in the context of the "OECD Conceptual Framework for Testing and Assessment of Endocrine Disrupting Chemicals" (11). The method comprises the basic repeated dose toxicity study that may be used for chemicals on which a 90-day study is not warranted (e.g. when the production volume does not exceed certain limits) or as a preliminary to a long-term study. The duration of exposure should be 28 days.
5. The international program conducted on the validation of parameters suitable to potentially detect endocrine activity of a test chemical showed that the quality of data obtained by this Test Method B.7 will depend much on the experience of the test laboratory. This relates specifically to the histopathological determination of cyclic changes in the female reproductive organs and to the weight determination of the small hormone dependent organs which are difficult to dissect. Guidance on histopathology has been developed (19). It is available on the OECD public website on Test Guidelines. It is intended to assist pathologists in their examinations and help increase the sensitivity of the assay. A variety of parameters were found to be indicative of endocrine-related toxicity and have been incorporated in the Test Method. Parameters for which insufficient data were available to prove usefulness or which showed only weak evidence in the validation programme of their ability to help in detection of endocrine disrupters are proposed as optional endpoints (see Appendix 2).
6. On the basis of data generated in the validation process, it must be emphasised that the sensitivity of this assay is not sufficient to identify all substances with (anti)androgenic or (anti)oestrogenic modes of action (9). The Test Method is not performed in a life-stage that is most sensitive to endocrine disruption. The Test Method nevertheless, during the validation process identified substances weakly and strongly affecting thyroid function, and strong and moderate endocrine active substances acting through oestrogen or androgen receptors, but in most cases failed to identify endocrine active substances that weakly affect oestrogen or androgen receptors. Thus it cannot be described as a screening assay for endocrine activity.
7. Consequently, the lack of effects related to these modes of action can not be taken as evidence for the lack of effects on the endocrine system. Regarding endocrine mediated effects, substance characterisation should not therefore be based on the results of this Test Method alone but should be used in a weight of evidence approach incorporating all existing data on a chemical to characterise potential endocrine activity. For this reason, regulatory decision making on endocrine activity (substance characterisation) should be a broadly based approach, not solely reliant on results from application of this test method.

8. It is acknowledged that all animal-based procedures will conform to local standards of animal care; the descriptions of care and treatment set forth below are minimal performance standards, and will be superseded by local regulations where more stringent. Further guidance of the humane treatment of animals is given by the OECD (14).
9. Definitions used are given in Appendix 1.

#### PRINCIPLE OF THE TEST

10. The test chemical is orally administered daily in graduated doses to several groups of experimental animals, one dose level per group for a period of 28 days. During the period of administration the animals are observed closely, each day for signs of toxicity. Animals that die or are euthanised during the test are necropsied and at the conclusion of the test surviving animals are euthanised and necropsied. A 28 day study provides information on the effects of repeated oral exposure and can indicate the need for further longer term studies. It can also provide information on the selection of concentrations for longer term studies. The data derived from using the Test Method should allow for the characterisation of the test chemical toxicity, for an indication of the dose response relationship and the determination of the No-Observed Adverse Effect Level (NOAEL).

#### DESCRIPTION OF THE METHOD

##### **Selection of animal species**

11. The preferred rodent species is the rat, although other rodent species may be used. If the parameters specified within this Test Method B.7 are investigated in another rodent species a detailed justification should be given. Although it is biologically plausible that other species should respond to toxicants in a similar manner to the rat, the use of smaller species may result in increased variability due to technical challenges of dissecting smaller organs. In the international validation program for the detection of endocrine disruptors, the rat was the only species used. Young healthy adult animals of commonly used laboratory strains should be employed. Females should be nulliparous and non pregnant. Dosing should begin as soon as feasible after weaning, and, in any case, before the animals are nine weeks old. At the commencement of the study the weight variation of animals used should be minimal and not exceed  $\pm 20\%$  of the mean weight of each sex. When a repeated oral dose is conducted as a preliminary to a longer-term study, it is preferable that animals from the same strain and source should be used in both studies.

##### **Housing and feeding**

12. All procedures should conform to local standards of laboratory animal care. The temperature in the experimental animal room should be  $22\text{ }^{\circ}\text{C}$  ( $\pm 3\text{ }^{\circ}\text{C}$ ). Although the relative humidity should be at least 30 % and preferably not to exceed 70 % other than during room cleaning, the aim should be 50-60 %. Lighting should be artificial, the photoperiod being 12 hours light, 12 hours dark. For feeding, conventional laboratory diets may be used with an unlimited supply of drinking water. The choice of diet may be influenced by the need to ensure a suitable admixture of a test chemical when administered by this method. Animals should be group housed in small groups of the same sex; animals may be housed individually if scientifically justified. For group caging, no more than five animals should be housed per cage.
13. The feed should be regularly analysed for contaminants. A sample of the diet should be retained until finalisation of the report.

##### **Preparation of animals**

14. Healthy young adult animals are randomly assigned to the control and treatment groups. Cages should be arranged in such a way that possible effects due to cage placement are minimised. The animals are identified uniquely and kept in their cages for at least five days prior to the start of the treatment study to allow for acclimatisation to the laboratory conditions.

##### **Preparation of doses**

15. The test chemical is administered by gavage or via the diet or drinking water. The method of oral administration is dependent on the purpose of the study, and the physical/chemical/toxico-kinetic properties of the test chemical.
16. Where necessary, the test chemical is dissolved or suspended in a suitable vehicle. It is recommended that, wherever possible, the use of an aqueous solution/suspension be considered first, followed by consideration of a solution/suspension in oil (e.g. corn oil) and then by possible solution in other vehicles. For vehicles other than water the toxic characteristics of the vehicle must be known. The stability of the test chemical in the vehicle should be determined.



## PROCEDURE

### Number and sex of animals

17. At least 10 animals (five female and five male) should be used at each dose level. If interim euthanasia are planned, the number should be increased by the number of animals scheduled to be euthanised before the completion of the study. Consideration should be given to an additional satellite group of ten animals (five per sex) in the control and in the top dose group for observation of reversibility, persistence, or delayed occurrence of toxic effects, for at least 14 days post treatment.

### Dosage

18. Generally, at least three test groups and a control group should be used, but if from assessment of other data, no effects would be expected at a dose of 1 000 mg/kg bw/d, a limit test may be performed. If there are no suitable data available, a range finding study (animals of the same strain and source) may be performed to aid the determination of the doses to be used. Except for treatment with the test chemical, animals in the control group should be handled in an identical manner to the test group subjects. If a vehicle is used in administering the test chemical, the control group should receive the vehicle in the highest volume used.
19. Dose levels should be selected taking into account any existing toxicity and (toxico-) kinetic data available for the test chemical or related chemicals. The highest dose level should be chosen with the aim of inducing toxic effects but not death or severe suffering. Thereafter, a descending sequence of dose levels should be selected with a view to demonstrating any dosage related response and no-observed-adverse effects at the lowest dose level (NOAEL). Two to four fold intervals are frequently optimal for setting the descending dose levels and addition of a fourth test group is often preferable to using very large intervals (e.g. more than a factor of 10) between dosages.
20. In the presence of observed general toxicity (e.g. reduced body weight, liver, heart, lung or kidney effects, etc.) or other changes that may not be toxic responses (e.g. reduced food intake, liver enlargement), observed effects on immune, neurological or endocrine sensitive endpoints should be interpreted with caution.

### Limit test

21. If a test at one dose level of at least 1 000 mg/kg body weight/day or, for dietary or drinking water administration, an equivalent percentage in the diet, or drinking water (based upon body weight determinations), using the procedures described for this study, produces no observable toxic effects and if toxicity would not be expected based upon data from structurally related chemicals, then a full study using three dose levels may not be considered necessary. The limit test applies except when human exposure indicates the need for a higher dose level to be used.

### Administration of doses

22. The animals are dosed with test chemical daily 7 days each week for a period of 28 days. When the test chemical is administered by gavage, this should be done in a single dose to the animals using a stomach tube or a suitable intubation cannula. The maximum volume of liquid that can be administered at one time depends on the size of the test animal. The volume should not exceed 1 ml/100 g body weight except in the case of aqueous solutions where 2 ml/100 g body weight may be used. Except for irritating or corrosive chemicals, which will normally reveal exacerbated effects with higher concentrations, variability in test volume should be minimized by adjusting the concentration to ensure a constant volume at all dose levels.
23. For chemicals administered via the diet or drinking water it is important to ensure that the quantities of the test chemical involved do not interfere with normal nutrition or water balance. When the test chemical is administered in the diet either a constant dietary concentration (ppm) or a constant dose level in terms of the animals' body weight may be used; the alternative used must be specified. For a chemical administered by gavage, the dose should be given at similar times each day, and adjusted as necessary to maintain a constant dose level in terms of animal body weight. Where a repeated dose study is used as a preliminary to a long term study, a similar diet should be used in both studies.

### Observations

24. The observation period should be 28 days. Animals in a satellite group scheduled for follow-up observations should be kept for at least 14 days without treatment to detect delayed occurrence, or persistence of, or recovery from toxic effects.
25. General clinical observations should be made at least once a day, preferably at the same time(s) each day and considering the peak period of anticipated effects after dosing. The health condition of the animals should be recorded. At least twice daily, all animals are observed for morbidity and mortality.



26. Once before the first exposure (to allow for within-subject comparisons), and at least once a week thereafter, detailed clinical observations should be made in all animals. These observations should be made outside the home cage in a standard arena and preferably at the same time of day on each occasion. They should be carefully recorded, preferably using scoring systems, explicitly defined by the testing laboratory. Effort should be made to ensure that variations in the test conditions are minimal and that observations are preferably conducted by observers unaware of the treatment. Signs noted should include, but not be limited to, changes in skin, fur, eyes, mucous membranes, occurrence of secretions and excretions and autonomic activity (e.g. lacrimation, piloerection, pupil size, unusual respiratory pattern). Changes in gait, posture and response to handling as well as the presence of clonic or tonic movements, stereotypies (e.g. excessive grooming, repetitive circling) or bizarre behaviour (e.g. self-mutilation, walking backwards) should also be recorded (2).
27. In the fourth exposure week sensory reactivity to stimuli of different types (2) (e.g. auditory, visual and proprioceptive stimuli) (3)(4)(5), assessment of grip strength (6) and motor activity assessment (7) should be conducted. Further details of the procedures that could be followed are given in the respective references. However, alternative procedures than those referenced could be used.
28. Functional observations conducted in the fourth exposure week may be omitted when the study is conducted as a preliminary study to a subsequent subchronic (90-day) study. In that case, the functional observations should be included in this follow-up study. On the other hand, the availability of data on functional observations from the repeated dose study may enhance the ability to select dose levels for a subsequent subchronic study.
29. As an exception, functional observations may also be omitted for groups that otherwise reveal signs of toxicity to an extent that would significantly interfere with the functional test performance.
30. At necropsy, the oestrus cycle of all females could be determined (optional) by taking vaginal smears. These observations will provide information regarding the stage of oestrus cycle at the time of sacrifice and assist in histological evaluation of estrogen sensitive tissues [see guidance on histopathology (19)].

#### **Body weight and food/water consumption**

31. All animals should be weighed at least once a week. Measurements of food consumption should be made at least weekly. If the test chemical is administered via the drinking water, water consumption should also be measured at least weekly.

#### **Haematology**

32. The following haematological examinations should be made at the end of the test period: haematocrit, haemoglobin concentrations, erythrocyte count, reticulocytes, total and differential leucocyte count, platelet count and a measure of blood clotting time/potential. Other determinations that should be carried out, if the test chemical or its putative metabolites have or are suspected to have oxidising properties include methaemoglobin concentration and Heinz bodies.
33. Blood samples should be taken from a named site just prior to or as part of the procedure for euthanasia of the animals, and stored under appropriate conditions. Animals should be fasted overnight prior to euthanasia <sup>(1)</sup>.

#### **Clinical biochemistry**

34. Clinical biochemistry determinations to investigate major toxic effects in tissues and, specifically, effects on kidney and liver, should be performed on blood samples obtained of all animals just prior to or as part of the procedure for euthanasia of the animals (apart from those found moribund and/or euthanised prior to the termination of the study). Investigations of plasma or serum shall include sodium, potassium, glucose, total cholesterol, urea, creatinine, total protein and albumin, at least two enzymes indicative of hepatocellular effects (such as alanin aminotransferase, aspartate aminotransferase, alkaline phosphatase,  $\gamma$ -glutamyl trans-peptidase and glutamate dehydrogenase), and bile acids. Measurements of additional enzymes (of hepatic or other origin) and bilirubin may provide useful information under certain circumstances.
35. Optionally, the following urinalysis determinations could be performed during the last week of the study using timed urine volume collection; appearance, volume, osmolality or specific gravity, pH, protein, glucose and blood/blood cells.

<sup>(1)</sup> For a number of measurements in serum and plasma, most notably for glucose, overnight fasting would be preferable. The major reason for this preference is that the increased variability which would inevitably result from non-fasting, would tend to mask more subtle effects and make interpretation difficult. On the other hand, however, overnight fasting may interfere with the general metabolism of the animals and, particularly in feeding studies, may disturb the daily exposure to the test chemical. If overnight fasting is adopted, clinical biochemical determinations should be performed after the conduct of functional observations in week 4 of the study.

36. In addition, studies to investigate plasma or serum markers of general tissue damage should be considered. Other determinations that should be carried out, if the known properties of the test chemical may, or are suspected to, affect related metabolic profiles include calcium, phosphate, triglycerides, specific hormones, and cholinesterase. These need to be identified for chemicals in certain classes or on a case-by-case basis.
37. Although in the international evaluation of the endocrine related endpoints a clear advantage for the determination of thyroid hormones (T3, T4) and TSH could not be demonstrated, it may be helpful to retain plasma or serum samples to measure T3, T4 and TSH (optional) if there is an indication for an effect on the pituitary-thyroid axis. These samples may be frozen at  $-20^{\circ}$  for storage. The following factors may influence the variability and the absolute concentrations of the hormone determinations:
- time of sacrifice because of diurnal variation of hormone concentrations
  - method of sacrifice to avoid undue stress to the animals that may affect hormone concentrations
  - test kits for hormone determinations that may differ by their standard curves.

Definitive identification of thyroid-active chemicals is more reliable by histopathological analysis rather than hormone levels.

38. Plasma samples specifically intended for hormone determination should be obtained at a comparable time of the day. It is recommended that consideration should be given to T3, T4 and TSH determinations triggered based upon alterations of thyroid histopathology. The numerical values obtained when analysing hormone concentrations differ with various commercial assay kits. Consequently, it may not be possible to provide performance criteria based upon uniform historical data. Alternatively, laboratories should strive to keep control coefficients of variation below 25 for T3 and T4 and below 35 for TSH. All concentrations are to be recorded in ng/ml.
39. If historical baseline data are inadequate, consideration should be given to determination of haematological and clinical biochemistry variables before dosing commences or preferably in a set of animals not included in the experimental groups.

#### PATHOLOGY

##### Gross necropsy

40. All animals in the study shall be subjected to a full, detailed gross necropsy which includes careful examination of the external surface of the body, all orifices, and the cranial, thoracic and abdominal cavities and their contents. The liver, kidneys, adrenals, testes, epididymides, prostate + seminal vesicles with coagulating glands as a whole, thymus, spleen, brain and heart of all animals (apart from those found moribund and/or euthanised prior to the termination of the study) should be trimmed of any adherent tissue, as appropriate, and their wet weight taken as soon as possible after dissection to avoid drying. Care must be exercised when trimming the prostate complex to avoid puncture of the fluid filled seminal vesicles. Alternatively, seminal vesicles and prostate may be trimmed and weighed after fixation.
41. In addition, two other tissues could be optionally weighed as soon as possible after dissection, to avoid drying: paired ovaries (wet weight) and uterus, including cervix (guidance on removal and preparation of the uterine tissues for weight measurement is provided in OECD TG 440 (18)).
42. The thyroid weight (optional) could be determined after fixation. Trimming should also be done very carefully and only after fixation to avoid tissue damage. Tissue damage could compromise histopathology analysis.
43. The following tissues should be preserved in the most appropriate fixation medium for both the type of tissue and the intended subsequent histopathological examination (see paragraph 47): all gross lesions, brain (representative regions including cerebrum, cerebellum and pons), spinal cord, eye, stomach, small and large intestines (including Peyer's patches), liver, kidneys, adrenals, spleen, heart, thymus, thyroid, trachea and lungs (preserved by inflation with fixative and then immersion), gonads (testis and ovaries), accessory sex organs (uterus and cervix, epididymides, prostate + seminal vesicles with coagulating glands), vagina, urinary bladder, lymph nodes [besides the most proximal draining node another lymph node should be taken according to the laboratory's experience (15)], peripheral nerve (sciatic or tibial) preferably in close proximity to the muscle, skeletal muscle and bone, with bone marrow (section or, alternatively, a fresh mounted bone marrow aspirate). It is recommended that testes be fixed by immersion in Bouin's or modified Davidson's fixative (16) (17). The tunica albuginea must be gently and shallowly punctured at the both poles of the organ with a needle to permit rapid penetration of the fixative. The clinical and other findings may suggest the need to examine additional tissues. Also any organs considered likely to be target organs based on the known properties of the test chemical should be preserved.

44. The following tissues may give valuable indication for endocrine-related effects: Gonads (ovaries and testes), accessory sex organs (uterus including cervix, epididymides, seminal vesicles with coagulation glands, dorso-lateral and ventral prostate), vagina, pituitary, male mammary gland, the thyroid and adrenal gland. Changes in male mammary glands have not been sufficiently documented but this parameter may be very sensitive to substances with oestrogenic action. Observation of organs/tissues that are not listed in paragraph 43 is optional (see Appendix 2).
45. The Guidance on histopathology (19) details extra information on dissection, fixation, sectioning and histopathology of endocrine tissues.
46. In the international test program some evidence was obtained that subtle endocrine effects by chemicals with a low potency for affecting sex hormone homeostasis may be identified by disturbance of the synchronisation of the oestrus cycle in different tissues and not so much by frank histopathological alterations in female sex organs. Although no definitive proof was obtained for such effects, it is recommended that evidence of possible asynchrony of the oestrus cycle should be taken into account in interpretation of the histopathology of the ovaries (follicular, thecal, and granulosa cells), uterus, cervix and vagina. If assessed, the stage of cycle as determined by vaginal smears could be included in this comparison as well.

### **Histopathology**

47. Full histopathology should be carried out on the preserved organs and tissues of all animals in the control and high dose groups. These examinations should be extended to animals of all other dosage groups, if treatment-related changes are observed in the high dose group.
48. All gross lesions shall be examined.
49. When a satellite group is used, histopathology should be performed on tissues and organs identified as showing effects in the treated groups.

### **DATA AND REPORTING**

#### **Data**

50. Individual data should be provided. Additionally, all data should be summarised in tabular form showing for each test group the number of animals at the start of the test, the number of animals found dead during the test or euthanised for humane reasons and the time of any death or euthanasia, the number showing signs of toxicity, a description of the signs of toxicity observed, including time of onset, duration, and severity of any toxic effects, the number of animals showing lesions, the type of lesions, their severity and the percentage of animals displaying each type of lesion.
51. When possible, numerical results should be evaluated by an appropriate and generally acceptable statistical method. Comparisons of the effect along a dose range should avoid the use of multiple t-tests. The statistical methods should be selected during the design of the study.
52. For quality control it is proposed that historical control data are collected and that for numerical data coefficients of variation are calculated, especially for the parameters linked with endocrine disrupter detection. These data can be used for comparison purposes when actual studies are evaluated.

#### **Test report**

53. The test report must include the following information:

##### *Test chemical:*

- physical nature, purity and physicochemical properties;
- identification data.

##### *Vehicle (if appropriate):*

- justification for choice of vehicle, if other than water.

*Test animals:*

- species/strain used;
- number, age and sex of animals;
- source, housing conditions, diet, etc.;
- individual weights of animals at the start of the test.
- justification for species if not rat

*Test conditions:*

- rationale for dose level selection;
- details of test chemical formulation/diet preparation, achieved concentration, stability and homogeneity of the preparation;
- details of the administration of the test chemical;
- conversion from diet/drinking water test chemical concentration (ppm) to the actual dose (mg/kg body weight/day), if applicable;
- details of food and water quality.

*Optional endpoints investigated*

- list of optional endpoints investigated

*Results:*

- body weight/body weight changes;
- food consumption, and water consumption, if applicable;
- toxic response data by sex and dose level, including signs of toxicity;
- nature, severity and duration of clinical observations (whether reversible or not);
- sensory activity, grip strength and motor activity assessments;
- haematological tests with relevant base-line values;
- clinical biochemistry tests with relevant base-line values;
- body weight at euthanasia and organ weight data;
- necropsy findings;
- a detailed description of all histopathological findings;
- absorption data if available;
- statistical treatment of results, where appropriate.

*Discussion of results**Conclusions*

---

*Appendix 1*

## DEFINITIONS

**Androgenicity** is the capability of a chemical to act like a natural androgenic hormone (e.g. testosterone) in a mammalian organism.

**Antiandrogenicity** is the capability of a chemical to suppress the action of a natural androgenic hormone (e.g. testosterone) in a mammalian organism.

**Antioestrogenicity** is the capability of a chemical to suppress the action of a natural oestrogenic hormone (e.g. oestradiol 17 $\beta$ ) in a mammalian organism.

**Antithyroid activity** is the capability of a chemical to suppress the action of a natural thyroid hormone (e.g. T<sub>3</sub>) in a mammalian organism.

**Dosage** is a general term comprising of dose, its frequency and the duration of dosing.

**Dose** is the amount of test chemical administered. The dose is expressed as weight of test chemical per unit body weight of test animal per day (e.g. mg/kg body weight/day), or as a constant dietary concentration.

**Evident toxicity** is a general term describing clear signs of toxicity following administration of test chemical. These should be sufficient for hazard assessment and should be such that an increase in the dose administered can be expected to result in the development of severe toxic signs and probable mortality.

**NOAEL** is the abbreviation for no-observed-adverse-effect level. This is the highest dose level where no adverse treatment-related findings are observed due to treatment.

**Oestrogenicity** is the capability of a chemical to act like a natural oestrogenic hormone (e.g. oestradiol 17 $\beta$ ) in a mammalian organism.

**Test chemical:** Any substance or mixture tested using this Test Method.

**Thyroid activity** is the capability of a chemical to act like a natural thyroid hormone (e.g. T<sub>3</sub>) in a mammalian organism.

**Validation** is a scientific process designed to characterise the operational requirements and limitations of a test method and to demonstrate its reliability and relevance for a particular purpose.

---

## Appendix 2

**Endpoints recommended for the detection of endocrine disruptors (EDs) in this Test Method B.7**

Mandatory endpoints	Optional endpoints
Weight	
<ul style="list-style-type: none"> <li>— Testes</li> <li>— Epididymides</li> <li>— Adrenals</li> <li>— Prostate + seminal vesicles with coagulating glands</li> </ul>	<ul style="list-style-type: none"> <li>— Ovaries</li> <li>— Uterus, including cervix</li> <li>— Thyroid</li> </ul>
Histopathology	
<ul style="list-style-type: none"> <li>— Gonads: <ul style="list-style-type: none"> <li>— Testes and</li> <li>— Ovaries</li> </ul> </li> <li>— Accessory sex organs: <ul style="list-style-type: none"> <li>— Epididymides,</li> <li>— Prostate + seminal vesicle with coagulating glands</li> <li>— Uterus, including cervix</li> </ul> </li> <li>— Adrenal</li> <li>— Thyroid</li> <li>— Vagina</li> </ul>	<ul style="list-style-type: none"> <li>— Vaginal smears</li> <li>— Male mammary glands</li> <li>— Pituitary</li> </ul>
Hormones measurement	
	<ul style="list-style-type: none"> <li>— Circulating levels of T3, T4</li> <li>— Circulating levels of TSH</li> </ul>

**LITERATURE:**

- (1) OECD (Paris, 1992). Chairman's Report of the Meeting of the ad hoc Working Group of Experts on Systemic Short-term and (Delayed) Neurotoxicity.
- (2) IPCS (1986). Principles and Methods for the Assessment of Neurotoxicity Associated with Exposure to Chemicals. Environmental Health Criteria Document No 60.
- (3) Tupper DE, Wallace RB (1980). Utility of the Neurologic Examination in Rats. *Acta Neurobiol. Exp.* 40: 999-1003.
- (4) Gad SC (1982). A Neuromuscular Screen for Use in Industrial Toxicology. *J. Toxicol Environ. Health* 9: 691-704.
- (5) Moser VC, McDaniel KM, Phillips PM (1991). Rat Strain and Stock Comparisons Using a Functional Observational Battery: Baseline Values and Effects of Amitraz. *Toxicol. Appl. Pharmacol.* 108: 267-283.
- (6) Meyer OA, Tilson HA, Byrd WC, Riley MT (1979). A Method for the Routine Assessment of Fore- and Hindlimb Grip Strength of Rats and Mice. *Neurobehav. Toxicol.* 1: 233-236.
- (7) Crofton KM, Howard JL, Moser VC, Gill MW, Reiter LW, Tilson HA, MacPhail RC (1991). Interlaboratory Comparison of Motor Activity Experiments: Implication for Neurotoxicological Assessments. *Neurotoxicol. Teratol.* 13: 599-609.
- (8) OECD (1998). Report of the First Meeting of the OECD Endocrine Disrupter Testing and Assessment (EDTA) Task Force, 10th-11 March 1998, ENV/MC/CHEM/RA(98)5.
- (9) OECD. (2006). Report of the Validation of the Updated Test Guideline 407: Repeat Dose 28-day Oral Toxicity Study in Laboratory Rats. Series on Testing and Assessment No 59, ENV/JM/MONO(2006)26.

- (10) OECD (2002). Detailed Review Paper on the Appraisal of Test Methods for Sex Hormone Disrupting Chemicals. Series on Testing and Assessment No 21, ENV/JM/MONO(2002)8.
- (11) OECD (2012). Conceptual Framework for Testing and Assessment of Endocrine Disrupting Chemicals. [http://www.oecd.org/document/58/0,3343,fr\\_2649\\_37407\\_2348794\\_1\\_1\\_1\\_37407,00.html](http://www.oecd.org/document/58/0,3343,fr_2649_37407_2348794_1_1_1_37407,00.html)
- (12) OECD (2006). Final Summary report of the meeting of the Validation Management Group for mammalian testing. ENV/JM/TG/EDTA/M(2006)2.
- (13) OECD. Draft Summary record of the meeting of the Task Force on Endocrine Disrupters Testing and Assessment. ENV/JM/TG/EDTA/M(2006)3.
- (14) OECD (2000). Guidance document on the recognition, assessment and use of clinical signs as humane endpoints for experimental animals used in safety evaluation. Series on Testing and Assessment No 19. ENV/JM/MONO(2000)7.
- (15) Haley P, Perry R, Ennulat D, Frame S, Johnson C, Lapointe J-M, Nyska A, Snyder PW, Walker D, Walter G (2005). STP Position Paper: Best Practice Guideline for the Routine Pathology Evaluation of the Immune System. Toxicol Pathol 33: 404-407.
- (16) Hess RA, Moore BJ (1993). Histological Methods for the Evaluation of the Testis. In: Methods in Reproductive Toxicology, Chapin RE and Heindel JJ (eds). Academic Press: San Diego, CA, pp. 52-85.
- (17) Latendresse JR, Warbritton AR, Jonassen H, Creasy DM.(2002) Fixation of testes and eyes using a modified Davidson's fluid: comparison with Bouin's fluid and conventional Davidson's fluid. Toxicol. Pathol. 30, 524-533.
- (18) OECD (2007). OECD Guideline for Testing of Chemicals No 440: Uterotrophic Bioassay in Rodents: A short-term screening test for oestrogenic properties.
- (19) OECD (2009). Guidance Document 106 on Histologic evaluation of Endocrine and Reproductive Tests in Rodents ENV/JM/Mono(2009)11.

#### B.8. SUBACUTE INHALATION TOXICITY: 28-DAY STUDY

##### SUMMARY

This revised Test Method B.8 has been designed to fully characterise test chemical toxicity by the inhalation route following repeated exposure for a limited period of time (28 days), and to provide data for quantitative inhalation risk assessments. Groups of at least 5 male and 5 female rodents are exposed 6 hours per day for 28 days to a) the test chemical at three or more concentration levels, b) filtered air (negative control), and/or c) the vehicle (vehicle control). Animals are generally exposed 5 days per week but exposure for 7 days per week is also allowed. Males and females are always tested, but they may be exposed at different concentration levels if it is known that one sex is more susceptible to a given test chemical. This method allows the study director the flexibility to include satellite (reversibility) groups, bronchoalveolar lavage (BAL), neurologic tests, and additional clinical pathology and histopathological evaluations in order to better characterise the toxicity of a test chemical.

##### INTRODUCTION

1. This Test Method is equivalent to OECD Test Guideline 412 (2009). The original subacute inhalation Test Guideline 412 (TG 412) was adopted in 1981 (1). This Test Method B.8 (as equivalent to the revised TG 412) has been updated to reflect the state of science and to meet current and future regulatory needs.
2. This method enables the characterisation of adverse effects following repeated daily inhalation exposure to a test chemical for 28 days. The data derived from 28-day sub-acute inhalation toxicity studies can be used for quantitative risk assessments [if not followed by a 90-day subchronic inhalation toxicity study (Chapter B.29 of this Annex)]. The data can also provide information on the selection of concentrations for longer term studies such as the 90-day subchronic inhalation toxicity study. This test method is not specifically intended for the testing of nanomaterials. Definitions used in the context of this Test Method are provided at the end of this chapter and in the Guidance Document 39 (2).

#### INITIAL CONSIDERATIONS

3. All available information on the test chemical should be considered by the testing laboratory prior to conducting the study in order to enhance the quality of the study and minimize animal usage. Information that will assist in the selection of appropriate test concentrations might include the identity, chemical structure, and physico-chemical properties of the test chemical; results of any *in vitro* or *in vivo* toxicity tests; anticipated use(s) and potential for human exposure; available (Q)SAR data and toxicological data on structurally related chemicals; and data derived from acute inhalation toxicity testing. If neurotoxicity is expected or is observed in the course of the study, the study director may choose to include appropriate evaluations such as a functional observational battery (FOB) and measurement of motor activity. Although the timing of exposures relative to specific examinations may be critical, the performance of these additional activities should not interfere with the basic study design.
4. Dilutions of corrosive or irritating test chemicals may be tested at concentrations that will yield the desired degree of toxicity [refer to GD 39 (2)]. When exposing animals to these materials, the targeted concentrations should be low enough to not cause marked pain and distress, yet sufficient to extend the concentration-response curve to levels that reach the regulatory and scientific objective of the test. These concentrations should be selected on a case-by-case basis, preferably based upon an adequately designed range-finding study that provides information regarding the critical endpoint, any irritation threshold, and the time of onset (see paragraphs 11-13). The justification for concentration selection should be provided.
5. Moribund animals or animals obviously in pain or showing signs of severe and enduring distress should be humanely killed. Moribund animals are considered in the same way as animals that die on test. Criteria for making the decision to kill moribund or severely suffering animals, and guidance on the recognition of predictable or impending death, are the subject of an OECD Guidance Document on Humane Endpoints (3).

#### DESCRIPTION OF THE METHOD

##### **Selection of Animal Species**

6. Healthy young adult rodents of commonly used laboratory strains should be employed. The preferred species is the rat. Justification should be provided if other species are used.

##### **Preparation of Animals**

7. Females should be nulliparous and non-pregnant. On the day of randomisation, animals should be young adults 7 to 9 weeks of age. Body weights should be within  $\pm 20\%$  of the mean weight for each sex. The animals are randomly selected, marked for individual identification, and kept in their cages for at least 5 days prior to the start of the test to allow for acclimatisation to laboratory conditions.

##### **Animal Husbandry**

8. Animals should be individually identified, if possible with subcutaneous transponders, to facilitate observations and avoid confusion. The temperature of the experimental animal maintenance room should be  $22 \pm 3$  °C. The relative humidity should ideally be maintained in the range of 30 to 70 %, though this may not be possible when using water as a vehicle. Before and after exposures, animals generally should be caged in groups by sex and concentration, but the number of animals per cage should not interfere with clear observation of each animal and should minimise losses due to cannibalism and fighting. When animals are to be exposed nose-only, it may be necessary for them to be acclimated to the restraining tubes. The restraining tubes should not impose undue physical, thermal, or immobilisation stress on the animals. Restraint may affect physiological endpoints such as body temperature (hyperthermia) and/or respiratory minute volume. If generic data are available to show that no such changes occur to any appreciable extent, then pre-adaptation to the restraining tubes is not necessary. Animals exposed whole-body to an aerosol should be housed individually during exposure to prevent them from filtering the test aerosol through the fur of their cage mates. Conventional and certified laboratory diets may be used, except during exposure, accompanied with an unlimited supply of municipal drinking water. Lighting should be artificial, the sequence being 12 hours light/12 hours dark.

##### **Inhalation Chambers**

9. The nature of the test chemical and the object of the test should be considered when selecting an inhalation chamber. The preferred mode of exposure is nose-only (which term includes head-only, nose-only, or snout-only). Nose-only exposure is generally preferred for studies of liquid or solid aerosols and for vapours that may condense to form aerosols. Special objectives of the study may be better achieved by using a whole-body mode of exposure, but this should be justified in the study report. To ensure atmosphere stability when using a whole-body chamber, the total "volume" of the test animals should not exceed 5 % of the chamber volume. Principles of the nose-only and whole-body exposure techniques and their particular advantages and disadvantages are addressed in GD 39 (2).



## TOXICITY STUDIES

### Limit Concentrations

10. Unlike with acute studies, there are no defined limit concentrations in 28-day sub-acute inhalation toxicity studies. The maximum concentration tested should consider: (1) the maximum attainable concentration, (2) the "worst case" human exposure level, (3) the need to maintain an adequate oxygen supply, and/or (4) animal welfare considerations. In the absence of data-based limits, the acute limits of the Regulation (EC) No 1272/2008 (13) may be used (i.e. up to a maximum concentration of 5 mg/l for aerosols, 20 mg/l for vapours and 20 000 ppm for gases); refer to GD 39 (2). Justification should be provided if it is necessary to exceed these limits when testing gases or highly volatile test chemicals (e.g. refrigerants). The limit concentration should elicit unequivocal toxicity without causing undue stress to the animals or affecting their longevity (3).

### Range-Finding Study

11. Before commencing with the main study, it may be necessary to perform a range-finding study. A range-finding study is more comprehensive than a sighting study because it is not limited to concentration selection. Knowledge learned from a range-finding study can lead to a successful main study. A range-finding study may, for example, provide technical information regarding analytical methods, particle sizing, discovery of toxic mechanisms, clinical pathology and histopathological data, and estimations of what may be NOAEL and MTC concentrations in a main study. The study director may choose to use the range-finding study to identify the threshold of respiratory tract irritation (e.g. with histopathology of the respiratory tract, pulmonary function testing, or bronchoalveolar lavage), the upper concentration which is tolerated without undue stress to the animals, and the parameters that will best characterise a test chemical's toxicity.
12. A range-finding study may consist of one or more concentration levels. No more than three males and three females should be exposed at each concentration level. A range-finding study should last a minimum of 5 days and generally no more than 14 days. The rationale for the selection of concentrations for the main study should be provided in the study report. The objective of the main study is to demonstrate a concentration-response relationship based on what is anticipated to be the most sensitive endpoint. The low concentration should ideally be a no-observed-adverse effect concentration while the high concentration should elicit unequivocal toxicity without causing undue stress to the animals or affecting their longevity (3).
13. When selecting concentration levels for the range-finding study, all available information should be considered including structure-activity relationships and data for similar chemicals (see paragraph 3). A range-finding study may verify/refute what are considered to be the most sensitive mechanistically based endpoints, e.g. cholinesterase inhibition by organophosphates, methaemoglobin formation by erythrocytotoxic agents, thyroidal hormones (T<sub>3</sub>, T<sub>4</sub>) for thyrotoxicants, protein, LDH, or neutrophils in bronchoalveolar lavage for innocuous poorly soluble particles or pulmonary irritant aerosols.

### Main Study

14. The main sub-acute toxicity study generally consists of three concentration levels, and also concurrent negative (air) and/or vehicle controls as needed (see paragraph 17). All available data should be utilised to aid selection of appropriate exposure levels, including the results of systemic toxicity studies, metabolism and kinetics (particular emphasis should be given to avoiding high concentration levels which saturate kinetic processes). Each test group contains at least 10 rodents (5 male and 5 female) that are exposed to the test chemical for 6 hours per day on a 5 day per week basis for a period of 4 weeks (total study duration of 28 days). Animals may also be exposed 7 days per week (e.g. when testing inhaled pharmaceuticals). If one sex is known to be more susceptible to a given test chemical, the sexes may be exposed at different concentration levels in order to optimise the concentration-response as described in paragraph 15. If rodent species other than rats are exposed nose-only, maximum exposure durations may be adjusted to minimise species-specific distress. A rationale should be provided when using an exposure duration less than 6 hours/day, or when it is necessary to conduct a long duration (e.g. 22 hours/day) whole-body exposure study [refer to GD 39 (2)]. Feed should be withheld during the exposure period unless exposure exceeds 6 hours. Water may be provided throughout a whole-body exposure.
15. The target concentrations selected should identify the target organ(s) and demonstrate a clear concentration-response:
  - The high concentration level should result in toxic effects but not cause lingering signs or lethality which would prevent a meaningful evaluation.
  - The intermediate concentration level(s) should be spaced to produce a gradation of toxic effects between that of the low and high concentration.
  - The low concentration level should produce little or no evidence of toxicity.

### Satellite (Reversibility) Study

16. A satellite (reversibility) study may be used to observe reversibility, persistence, or delayed occurrence of toxicity for a post-treatment period of an appropriate length, but no less than 14 days. Satellite (reversibility) groups consist of five males and five females exposed contemporaneously with the experimental animals in the main study. Satellite (reversibility) study groups should be exposed to the test chemical at the highest concentration level and there should be concurrent air and/or vehicle controls as needed (see paragraph 17).

### Control Animals

17. Concurrent negative (air) control animals should be handled in a manner identical to the test group animals except that they are exposed to filtered air rather than test chemical. When water or another substance is used to assist in generating the test atmosphere, a vehicle control group, instead of a negative (air) control group, should be included in the study. Water should be used as the vehicle whenever possible. When water is used as the vehicle, the control animals should be exposed to air with the same relative humidity as the exposed groups. The selection of a suitable vehicle should be based on an appropriately conducted pre-study or historical data. If a vehicle's toxicity is not well known, the study director may choose to use both a negative (air) control and a vehicle control, but this is strongly discouraged. If historical data reveal that a vehicle is non-toxic, then there is no need for a negative (air) control group and only a vehicle control should be used. If a pre-study of a test chemical formulated in a vehicle reveals no toxicity, it follows that the vehicle is non-toxic at the concentration tested and this vehicle control should be used.

### EXPOSURE CONDITIONS

#### Administration of Concentrations

18. Animals are exposed to the test chemical as a gas, vapour, aerosol, or a mixture thereof. The physical state to be tested depends on the physico-chemical properties of the test chemical, the selected concentration, and/or the physical form most likely present during the handling and use of the test chemical. Hygroscopic and chemically reactive test chemicals should be tested under dry air conditions. Care should be taken to avoid generating explosive concentrations. Particulate material may be subjected to mechanical processes to decrease the particle size. Further guidance is provided in GD 39 (2).

#### Particle-Size Distribution

19. Particle sizing should be performed for all aerosols and for vapours that may condense to form aerosols. To allow for exposure of all relevant regions of the respiratory tract, aerosols with mass median aerodynamic diameters (MMAD) ranging from 1 to 3  $\mu\text{m}$  with a geometric standard deviation ( $\sigma_g$ ) in the range of 1,5 to 3,0 are recommended (4). Although a reasonable effort should be made to meet this standard, expert judgement should be provided if it cannot be achieved. For example, metal fume particles may be smaller than this standard, and charged particles and fibres may exceed it.

#### Test chemical Preparation in a Vehicle

20. Ideally, the test chemical should be tested without a vehicle. If it is necessary to use a vehicle to generate an appropriate test chemical concentration and particle size, water should be given preference. Whenever a test chemical is dissolved in a vehicle, its stability should be demonstrated.

### MONITORING OF EXPOSURE CONDITIONS

#### Chamber Airflow

21. The flow of air through the exposure chamber should be carefully controlled, continuously monitored, and recorded at least hourly during each exposure. The real-time monitoring of the test atmosphere concentration (or temporal stability) is an integral measurement of all dynamic parameters and provides an indirect means to control all relevant dynamic inhalation parameters. If the concentration is monitored real-time, the frequency of measurement of air flows may be reduced to one single measurement per exposure per day. Special consideration should be given to avoiding re-breathing in nose-only chambers. Oxygen concentration should be at least 19 % and carbon dioxide concentration should not exceed 1 %. If there is reason to believe that this standard cannot be met, oxygen and carbon dioxide concentrations should be measured. If measurements on the first day of exposure show that these gases are at proper levels, no further measurements should be necessary.

#### Chamber Temperature and Relative Humidity

22. Chamber temperature should be maintained at  $22 \pm 3$  °C. Relative humidity in the animals' breathing zone, for both nose-only and whole-body exposures, should be monitored continuously and recorded hourly during each exposure where possible. The relative humidity should preferably be maintained in the range of 30 to 70 %, but this may either be unattainable (e.g. when testing water based mixtures) or not measurable due to test chemical interference with the Test Method.

**Test chemical: Nominal Concentration**

23. Whenever feasible, the nominal exposure chamber concentration should be calculated and recorded. The nominal concentration is the mass of generated test chemical divided by the total volume of air passed through the inhalation chamber system. The nominal concentration is not used to characterise the animals' exposure, but a comparison of the nominal concentration and the actual concentration gives an indication of the generation efficiency of the test system, and thus may be used to discover generation problems.

**Test chemical: Actual Concentration**

24. The actual concentration is the test chemical concentration as sampled at the animals' breathing zone in an inhalation chamber. Actual concentrations can be obtained either by specific methods (e.g. direct sampling, adsorptive or chemical reactive methods, and subsequent analytical characterisation) or by non-specific methods such as gravimetric filter analysis. The use of gravimetric analysis is acceptable only for single component powder aerosols or aerosols of low volatility liquids and should be supported by appropriate pre-study test chemical-specific characterisations. Multi-component powder aerosol concentration may also be determined by gravimetric analysis. However, this requires analytical data which demonstrate that the composition of airborne material is similar to the starting material. If this information is not available, a reanalysis of the test chemical (ideally in its airborne state) at regular intervals during the course of the study may be necessary. For aerosolised agents that may evaporate or sublime, it should be shown that all phases were collected by the method chosen.
25. One lot of the test chemical should be used throughout the duration of the study, if possible, and the test sample should be stored under conditions that maintain its purity, homogeneity, and stability. Prior to the start of the study, there should be a characterisation of the test chemical including its purity and, if technically feasible, the identity, and quantities of identified contaminants and impurities. This can be demonstrated but is not limited by the following data: retention time and relative peak area, molecular weight from mass spectroscopy or gas chromatography analyses, or other estimates. Although the test sample's identity is not the responsibility of the test laboratory, it may be prudent for the test laboratory to confirm the sponsor's characterisation at least in a limited way (e.g. colour, physical nature, etc.).
26. The exposure atmosphere should be held as constant as practicable. A real-time monitoring device, such as an aerosol photometer for aerosols or a total hydrocarbon analyser for vapours may be used to demonstrate the stability of the exposure conditions. Actual chamber concentration should be measured at least 3 times during each exposure day for each exposure level. If not feasible due to limited air flow rates or low concentrations, one sample per exposure period is acceptable. Ideally, this sample should then be collected over the entire exposure period. Individual chamber concentration samples should deviate from the mean chamber concentration by no more than  $\pm 10\%$  for gases and vapours, and by no more than  $\pm 20\%$  for liquid or solid aerosols. Time to attain chamber equilibration ( $t_{95}$ ) should be calculated and reported. The duration of an exposure spans the time that the test chemical is generated. This takes into account the times required to attain chamber equilibration ( $t_{95}$ ) and decay. Guidance for estimating  $t_{95}$  can be found in GD 39 (2).
27. For very complex mixtures consisting of gases/vapours and aerosols (e.g. combustion atmospheres and test chemicals propelled from purpose-driven end-use products/devices), each phase may behave differently in an inhalation chamber. Therefore, at least one indicator substance (analyte), normally the principal active substance in the mixture, of each phase (gas/vapour and aerosol) should be selected. When the test chemical is a mixture, the analytical concentration should be reported for the total mixture, and not just for the active ingredient or the indicator substance (analyte). Additional information regarding actual concentrations can be found in GD 39 (2).

**Test chemical: Particle Size Distribution**

28. The particle size distribution of aerosols should be determined at least weekly for each concentration level by using a cascade impactor or an alternative instrument, such as an aerodynamic particle sizer (APS). If equivalence of the results obtained by a cascade impactor and the alternative instrument can be shown, then the alternative instrument may be used throughout the study.
29. A second device, such as a gravimetric filter or an impinger/gas bubbler, should be used in parallel to the primary instrument to confirm the collection efficiency of the primary instrument. The mass concentration obtained by particle size analysis should be within reasonable limits of the mass concentration obtained by filter analysis [see GD 39 (2)]. If equivalence can be demonstrated at all concentrations tested in the early phase of the study, then further confirmatory measurements may be omitted. For the sake of animal welfare, measures should be taken to minimise inconclusive data which may lead to a need to repeat a study.
30. Particle sizing should be performed for vapours if there is any possibility that vapour condensation may result in the formation of an aerosol, or if particles are detected in a vapour atmosphere with potential for mixed phases.

## OBSERVATIONS

31. The animals should be clinically observed before, during and after the exposure period. More frequent observations may be indicated depending on the response of the animals during exposure. When animal observation is hindered by the use of animal restraint tubes, poorly lit whole body chambers, or opaque atmospheres, animals should be carefully observed after exposure. Observations before the next day's exposure can assess any reversibility or exacerbation of toxic effects.
32. All observations are recorded with individual records being maintained for each animal. When animals are killed for humane reasons or found dead, the time of death should be recorded as precisely as possible.
33. Cage-side observations should include changes in the skin and fur, eyes, and mucous membranes; changes in the respiratory and circulatory systems, changes in the nervous system, and changes in somatomotor activity and behaviour patterns. Attention should be directed to observations of tremors, convulsions, salivation, diarrhoea, lethargy, sleep, and coma. The measurement of rectal temperatures may provide supportive evidence of reflex bradypnea or hypo/hyperthermia related to treatment or confinement. Additional assessments may be included in the study protocol such as kinetics, biomonitoring, lung function, retention of poorly soluble materials that accumulate in lung tissue, and behavioural changes.

## BODY WEIGHTS

34. Individual animal weights should be recorded shortly before the first exposure (day 0), twice weekly thereafter (for example: on Fridays and Mondays to demonstrate recovery over an exposure-free weekend or at a time interval to allow assessment of systemic toxicity), and at the time of death or euthanasia. If there are no effects in the first 2 weeks, body weights may be measured weekly for the remainder of the study. Satellite (reversibility) animals (if used) should continue to be weighed weekly throughout the recovery period. At study termination, all animals should be weighed shortly before sacrifice to allow for an unbiased calculated of organ to body weight ratios.

## FOOD AND WATER CONSUMPTION

35. Food consumption should be measured weekly. Water consumption may also be measured.

## CLINICAL PATHOLOGY

36. Clinical pathology assessments should be made for all animals, including control and satellite (reversibility) animals, when they are sacrificed. The time interval between the end of exposure and blood collection should be recorded, particularly when the reconstitution of the addressed endpoint is rapid. Sampling following the end of exposure is indicated for those parameters with a short plasma half-time (e.g. COHb, CHE, and MetHb).
37. Table 1 lists the clinical pathology parameters that are generally required for all toxicology studies. Urinalysis is not required on a routine basis, but may be performed when deemed useful based on expected or observed toxicity. The study director may choose to assess additional parameters in order to better characterise a test chemical's toxicity (e.g. cholinesterase, lipids, hormones, acid/base balance, methaemoglobin or Heinz bodies, creatine kinase, myeloid/erythroid ratio, troponins, arterial blood gases, lactate dehydrogenase, sorbitol dehydrogenase, glutamate dehydrogenase, and gamma glutamyl transpeptidase).

Table 1

## Standard Clinical Pathology Parameters

Haematology	
Erythrocyte count	Total leukocyte count
Haematocrit	Differential leukocyte count
Haemoglobin concentration	Platelet count
Mean corpuscular haemoglobin	Clotting potential (select one):
Mean corpuscular volume	— Prothrombin time
Mean corpuscular haemoglobin concentration	— Clotting time
Reticulocytes	— Partial thromboplastin time

Clinical Chemistry	
Glucose (*)	Alanine aminotransferase
Total cholesterol	Aspartate aminotransferase
Triglycerides	Alkaline phosphatase
Blood urea nitrogen	Potassium
Total bilirubin	Sodium
Creatinine	Calcium
Total protein	Phosphorus
Albumin	Chloride
Globulin	
Urinalysis (optional)	
Appearance (colour and turbidity)	Total protein
Volume	Glucose
Specific gravity or osmolality	Blood/blood cells
pH	

(\*) Because a lengthy fasting period can introduce bias in glucose measurements for the treated versus control animals, the study director should determine whether it is appropriate to fast the animals. If a fasting period is used, it should be appropriate to the species used; for the rat this may be 16 h (overnight fasting). Determination of fasting glucose may be carried out after overnight fasting during the last exposure week, or after overnight fasting prior to necropsy (in the latter case together with all other clinical pathology parameters).

38. When there is evidence that the lower respiratory tract (i.e., the alveoli) is the primary site of deposition and retention, then bronchoalveolar lavage (BAL) may be the technique of choice to quantitatively analyse hypothesis-based dose-effect parameters focusing on alveolitis, pulmonary inflammation, and phospholipidosis. This allows for dose-response and time-course changes of alveolar injury to be suitably probed. The BAL fluid may be analysed for total and differential leukocyte counts, total protein, and lactate dehydrogenase. Other parameters that may be considered are those indicative of lysosomal injury, phospholipidosis, fibrosis, and irritant or allergic inflammation which may include the determination of pro-inflammatory cytokines/chemokines. BAL measurements generally complement the results from histopathology examinations but cannot replace them. Guidance on how to perform lung lavage can be found in GD 39 (2).

#### GROSS PATHOLOGY AND ORGAN WEIGHTS

39. All test animals, including those which die during the test or are removed from the study for animal welfare reasons, should be subjected to complete exsanguination (if feasible) and gross necropsy. The time between the end of each animal's last exposure and their sacrifice should be recorded. If a necropsy cannot be performed immediately after a dead animal is discovered, the animal should be refrigerated (not frozen) at a temperature low enough to minimise autolysis. Necropsies should be performed as soon as possible, normally within a day or two. All gross pathological changes should be recorded for each animal with particular attention to any changes in the respiratory tract.
40. Table 2 lists the organs and tissues that should be preserved in a suitable medium during gross necropsy for histopathological examination. The preservation of the [bracketed] organs and tissues and any other organs and tissues is at the discretion of the study director. The **bolded** organs should be trimmed and weighed wet as soon as possible after dissection to avoid drying. The thyroid and epididymides should only be weighed if needed because trimming artefacts may hinder histopathological evaluation. Tissues and organs should be fixed in 10 % buffered formalin or another suitable fixative as soon as necropsy is performed, and no less than 24-48 hours prior to trimming depending on the fixative to be used.

Table 2

**Organs and Tissues Preserved During Gross Necropsy**

<b>Adrenals</b>	Seminal vesicles
Bone marrow (and/or fresh aspirate)	Spinal cord (cervical, mid-thoracic, and lumbar)
<b>Brain</b> (including sections of cerebrum, cerebellum, and medulla/pons)	<b>Spleen</b>
[Eyes (retina, optic nerve) and eyelids]	Stomach
<b>Heart</b>	<b>Testes</b>
<b>Kidneys</b>	<b>Thymus</b>
Larynx (3 levels, 1 level to include the base of the epiglottis)	Thyroid
<b>Liver</b>	Trachea (at least 2 levels including 1 longitudinal section through the carina and 1 transverse section)
<b>Lung</b> (all lobes at one level, including main bronchi)	[Urinary bladder]
Lymph nodes from the hilar region of the lung, especially for poorly soluble particulate test chemicals, For more in depth examinations and/or studies with immunological focus, additional lymph nodes may be considered, e.g. those from the mediastinal, cervical/submandibular and/or auricular regions.	Uterus
Nasopharyngeal tissues (at least 4 levels; 1 level to include the nasopharyngeal duct and the Nasal Associated Lymphoid Tissue(NALT))	All gross lesions
Oesophagus	
[Olfactory bulb]	
Ovaries	

41. The lungs should be removed intact, weighed, and instilled with a suitable fixative at a pressure of 20-30 cm of water to ensure that lung structure is maintained (5). Sections should be collected for all lobes at one level, including main bronchi, but if lung lavage is performed, the unlavaged lobe should be sectioned at three levels (not serial sections).
42. At least 4 levels of the nasopharyngeal tissues should be examined, one of which should include the nasopharyngeal duct, (5, 6, 7, 8, 9) to allow adequate examination of the squamous, transitional (non-ciliated respiratory), respiratory (ciliated respiratory) and olfactory epithelium, and the draining lymphatic tissue (NALT; 10, 11). Three levels of the larynx should be examined, and one of these levels should include the base of the epiglottis (12). At least two levels of the trachea should be examined including one longitudinal section through the carina of the bifurcation of the extrapulmonary bronchi and one transverse section.

**HISTOPATHOLOGY**

43. A histopathological evaluation of all the organs and tissues listed in Table 2 should be performed for the control and high concentration groups, and for all animals which die or are sacrificed during the study. Particular attention should be paid to the respiratory tract, target organs, and gross lesions. The organs and tissues that have lesions in the high concentration group should be examined in all groups. The study director may choose to perform histopathological evaluations for additional groups to demonstrate a clear concentration response. When a satellite (reversibility) group is used, histopathological evaluation should be performed for all tissues and organs identified as showing effects in the treated groups. If there are excessive early deaths or other problems in the high exposure group that compromise the significance of the data, the next lower concentration should be examined histopathologically. An attempt should be made to correlate gross observations with microscopic findings.

## DATA AND REPORTING

**Data**

44. Individual animal data on body weights, food consumption, clinical pathology, gross pathology, organ weights, and histopathology should be provided. Clinical observation data should be summarised in tabular form showing for each test group the number of animals used, the number of animals displaying specific signs of toxicity, the number of animals found dead during the test or killed for humane reasons, time of death of individual animals, a description and time course of toxic effects and reversibility, and necropsy findings. All results, quantitative and incidental, should be evaluated by an appropriate statistical method. Any generally accepted statistical method may be used and the statistical methods should be selected during the design of the study.

**Test Report**

45. The test report should include the following information, as appropriate:

*Test animals and husbandry*

- Description of caging conditions, including: number (or change in number) of animals per cage, bedding material, ambient temperature and relative humidity, photoperiod, and identification of diet.
- Species/strain used and justification for using a species other than the rat. Source and historical data may be provided, if they are from animals exposed under similar exposure, housing, and fasting conditions.
- Number, age, and sex of animals.
- Method of randomisation.
- Description of any pre-test conditioning including diet, quarantine, and treatment for disease.

*Test chemical*

- Physical nature, purity, and, where relevant, physico-chemical properties (including isomerisation).
- Identification data and Chemical Abstract Services (CAS) Registry Number, if known.

*Vehicle*

- Justification for use of vehicle and justification for choice of vehicle (if other than water).
- Historical or concurrent data demonstrating that the vehicle does not interfere with the outcome of the study.

*Inhalation chamber*

- Detailed description of the inhalation chamber including volume and a diagram.
- Source and description of equipment used for the exposure of animals as well as generation of the atmosphere.
- Equipment for measuring temperature, humidity, particle-size, and actual concentration.
- Source of air and system used for conditioning.
- Methods used for calibration of equipment to ensure a homogeneous test atmosphere.
- Pressure difference (positive or negative).
- Exposure ports per chamber (nose-only); location of animals in the chamber (whole-body).



- Stability of the test atmosphere.
- Location of temperature and humidity sensors and sampling of test atmosphere in the chamber.
- Treatment of air supplied/extracted.
- Air flow rates, air flow rate/exposure port (nose-only), or animal load/chamber (whole-body).
- Time to inhalation chamber equilibrium ( $t_{95}$ ).
- Number of volume changes per hour.
- Metering devices (if applicable).

#### *Exposure data*

- Rationale for target concentration selection in the main study.
- Nominal concentrations (total mass of test chemical generated into the inhalation chamber divided by the volume of air passed through the chamber).
- Actual test chemical concentrations collected from the animals' breathing zone; for mixtures that produce heterogeneous physical forms (gases, vapours, aerosols), each may be analysed separately.
- All air concentrations should be reported in units of mass ( $\text{mg/l}$   $\text{mg/m}^3$ , etc.) rather than in units of volume (ppm, ppb, etc.).
- Particle size distribution, mass median aerodynamic diameter (MMAD), and geometric standard deviation ( $\sigma_g$ ), including their methods of calculation. Individual particle size analyses should be reported.

#### *Test conditions*

- Details of test chemical preparation, including details of any procedures used to reduce the particle size of solids or to prepare solutions of the test chemical.
- A description (preferably including a diagram) of the equipment used to generate the test atmosphere and to expose the animals to the test atmosphere.
- Details of the equipment used to monitor chamber temperature, humidity, and chamber airflow (i.e. development of a calibration curve).
- Details of the equipment used to collect samples for determination of chamber concentration and particle size distribution.
- Details of the chemical analytical method used and method validation (including efficiency of recovery of test chemical from the sampling medium).
- Method of randomisation in assigning animals to test and control groups.
- Details of food and water quality (including diet type/source, water source).
- The rationale for the selection of test concentrations.

#### *Results*

- Tabulation of chamber temperature, humidity, and airflow.
- Tabulation of chamber nominal and actual concentration data.



- Tabulation of particle size data including analytical sample collection data, particle size distribution, and calculations of the MMAD and  $\sigma_g$ .
- Tabulation of response data and concentration level for each animal (i.e. animals showing signs of toxicity including mortality, nature, severity, time of onset, and duration of effects).
- Tabulation of individual animal weights.
- Tabulation of food consumption
- Tabulation of clinical pathology data
- Necropsy findings and histopathological findings for each animal, if available.
- Tabulation of any other parameters measured

#### *Discussion and interpretation of results*

- Particular emphasis should be made to the description of methods used to meet the criteria of this Test Method, e.g. the limit concentration or the particle size.
- The respirability of particles in light of the overall findings should be addressed, especially if the particle-size criteria could not be met.
- The consistency of methods used to determine nominal and actual concentrations, and the relation of actual concentration to nominal concentration should be included in the overall assessment of the study.
- The likely cause of death and predominant mode of action (systemic versus local) should be addressed.
- An explanation should be provided if there was a need to humanely sacrifice animals in pain or showing signs of severe and enduring distress, based on the criteria in the OECD Guidance Document on Humane Endpoints (3).
- The target organ(s) should be identified.
- The NOAEL and LOAEL should be determined.

#### *LITERATURE:*

- (1) OECD (1981). Subchronic Inhalation Toxicity Testing, Original Test Guideline No 412, Environment Directorate, OECD, Paris.
- (2) OECD (2009). Guidance Document on Acute Inhalation Toxicity Testing, Environmental Health and Safety Monograph Series on Testing and Assessment No 39, ENV/JM/MONO(2009)28, OECD, Paris.
- (3) OECD (2000). Guidance Document on the Recognition, Assessment and Use of Clinical Signs as Humane Endpoints for Experimental Animals Used in Safety Evaluation, Environmental Health and Safety Monograph Series on Testing and Assessment No 19, ENV/JM/MONO(2000)7, OECD, Paris.
- (4) Whalan JE and Redden JC (1994). Interim Policy for Particle Size and Limit Concentration Issues in Inhalation Toxicity Studies. Office of Pesticide Programs, United States Environmental Protection Agency.
- (5) Dungworth DL, Tyler WS, Plopper CE (1985). Morphological Methods for Gross and Microscopic Pathology (Chapter 9) in Toxicology of Inhaled Material, Witschi, H.P. and Brain, J.D. (eds), Springer Verlag Heidelberg, pp. 229-258.
- (6) Young JT (1981). Histopathological examination of the rat nasal cavity. *Fundam. Appl. Toxicol.* 1: 309-312.
- (7) Harkema JR (1990). Comparative pathology of the nasal mucosa in laboratory animals exposed to inhaled irritants. *Environ. Health Perspect.* 85: 231-238.

- 
- (8) Woutersen RA, Garderen-Hoetmer A, van Slootweg PJ, Feron VJ (1994). Upper respiratory tract carcinogenesis in experimental animals and in humans. In: Waalkes MP and Ward JM (eds) Carcinogenesis. Target Organ Toxicology Series, Raven Press, New York, 215-263.
  - (9) Mery S, Gross EA, Joyner DR, Godo M, Morgan KT (1994). Nasal diagrams: A tool for recording the distribution of nasal lesions in rats and mice. *Toxicol. Pathol.* 22: 353-372.
  - (10) Kuper CF, Koornstra PJ, Hameleers DMH, Biewenga J, Spit BJ, Duijvestijn AM, Breda Vriesman van PJC, Sminia T (1992). The role of nasopharyngeal lymphoid tissue. *Immunol. Today* 13: 219-224.
  - (11) Kuper CF, Arts JHE, Feron VJ (2003). Toxicity to nasal-associated lymphoid tissue. *Toxicol. Lett.* 140-141: 281-285.
  - (12) Lewis DJ (1981). Mitotic Indices of Rat Laryngeal Epithelia. *Journal of Anatomy* 132(3): 419-428.
  - (13) Regulation (EC) No 1272/2008 of the European Parliament and of the Council of 16 December 2008 on classification, labelling and packaging of substances and mixtures, amending and repealing Directives 67/548/EEC and 1999/45/EC, and amending Regulation (EC) No 1907/2006 (OJ L 353, 31.12.2008, p. 1).
-

## Appendix 1

## DEFINITION

**Test chemical:** Any substance or mixture tested using this Test Method.'

(5) Chapters B.29 and B.30 are replaced by the following:

**B.29. SUBCHRONIC INHALATION TOXICITY: 90-DAY STUDY**

## SUMMARY

This revised Test Method B.29 has been designed to fully characterise test chemical toxicity by the inhalation route for a subchronic duration (90 days), and to provide robust data for quantitative inhalation risk assessments. Groups of 10 male and 10 female rodents are exposed 6 hours per day during a 90 day (13 week) period to a) the test chemical at three or more concentration levels, b) filtered air (negative control), and/or c) the vehicle (vehicle control). Animals are generally exposed 5 days per week but exposure for 7 days per week is also allowed. Males and females are always tested, but they may be exposed at different concentration levels if it is known that one sex is more susceptible to a given test chemical. This method allows the study director the flexibility to include satellite (reversibility) groups, interim sacrifices, bronchoalveolar lavage (BAL), neurologic tests, and additional clinical pathology and histopathological evaluations in order to better characterise the toxicity of a test chemical.

## INTRODUCTION

1. This Test Method is equivalent to OECD Test Guideline 413 (2009). The original subchronic inhalation Test Guideline 413 (TG 413) was adopted in 1981 (1). This Test Method B.29 (as equivalent to the revised TG 413 (2009)) has been updated to reflect the state of the science and to meet current and future regulatory needs.
2. Subchronic inhalation toxicity studies are primarily used to derive regulatory concentrations for assessing worker risk in occupation settings. They are also used to assess human residential, transportation, and environmental risk. This method enables the characterisation of adverse effects following repeated daily inhalation exposure to a test chemical for 90 days (approximately 10 % of the lifespan of a rat). The data derived from subchronic inhalation toxicity studies can be used for quantitative risk assessments and for the selection of concentrations for chronic studies. This test method is not specifically intended for the testing of nanomaterials. Definitions used in the context of this Test Method are provided at the end of this chapter and in the Guidance Document (GD) 39 (2).

## INITIAL CONSIDERATIONS

3. All available information on the test chemical should be considered by the testing laboratory prior to conducting the study in order to enhance the quality of the study and minimise animal usage. Information that will assist in the selection of appropriate test concentrations might include the identity, chemical structure, and physico-chemical properties of the test chemical; results of any *in vitro* or *in vivo* toxicity tests; anticipated use(s) and potential for human exposure; available (Q)SAR data and toxicological data on structurally related chemicals; and data derived from other repeated exposure studies. If neurotoxicity is expected or is observed in the course of the study, the study director may choose to include appropriate evaluations such as a functional observational battery (FOB) and measurement of motor activity. Although the timing of exposures relative to specific examinations may be critical, the performance of these additional activities should not interfere with the basic study design.
4. Dilutions of corrosive or irritating test chemicals may be tested at concentrations that will yield the desired degree of toxicity. Please refer to GD 39 (2) for further information. When exposing animals to these materials, the targeted concentrations should be low enough to not cause marked pain and distress, yet sufficient to extend the concentration-response curve to levels that reach the regulatory and scientific objective of the test. These concentrations should be selected on a case-by-case basis, preferably based upon an adequately designed range-finding study that provides information regarding the critical endpoint, any irritation threshold, and the time of onset (see paragraphs 11-13). The justification for concentration selection should be provided.
5. Moribund animals or animals obviously in pain or showing signs of severe and enduring distress should be humanely killed. Moribund animals are considered in the same way as animals that die on test. Criteria for making the decision to kill moribund or severely suffering animals, and guidance on the recognition of predictable or impending death, are the subject of an OECD Guidance Document on Humane Endpoints (3).

## DESCRIPTION OF THE METHOD

### Selection of Animal Species

6. Healthy young adult rodents of commonly used laboratory strains should be employed. The preferred species is the rat. Justification should be provided if other species are used.

### Preparation of Animals

7. Females should be nulliparous and non-pregnant. On the day of randomisation, animals should be young adults 7 to 9 weeks of age. Body weights should be within  $\pm 20\%$  of the mean weight for each sex. The animals are randomly selected, marked for individual identification, and kept in their cages for at least 5 days prior to the start of the test to allow for acclimatization to laboratory conditions.

### Animal Husbandry

8. Animals should be individually identified, preferably with subcutaneous transponders, to facilitate observations and avoid confusion. The temperature of the experimental animal maintenance room should be  $22 \pm 3^\circ\text{C}$ . The relative humidity should ideally be maintained in the range of 30 to 70 %, though this may not be possible when using water as a vehicle. Before and after exposures, animals generally should be caged in groups by sex and concentration, but the number of animals per cage should not interfere with clear observation of each animal and should minimise losses due to cannibalism and fighting. When animals are to be exposed nose-only, it may be necessary for them to be acclimated to the restraining tubes. The restraining tubes should not impose undue physical, thermal, or immobilisation stress on the animals. Restraint may affect physiological endpoints such as body temperature (hyperthermia) and/or respiratory minute volume. If generic data are available to show that no such changes occur to any appreciable extent, then pre-adaptation to the restraining tubes is not necessary. Animals exposed whole-body to an aerosol should be housed individually during exposure to prevent them from filtering the test aerosol through the fur of their cage mates. Conventional and certified laboratory diets may be used, except during exposure, accompanied with an unlimited supply of municipal drinking water. Lighting should be artificial, the sequence being 12 hours light/12 hours dark.

### Inhalation Chambers

9. The nature of the test chemical and the object of the test should be considered when selecting an inhalation chamber. The preferred mode of exposure is nose-only (which term includes head-only, nose-only, or snout-only). Nose-only exposure is generally preferred for studies of liquid or solid aerosols and for vapours that may condense to form aerosols. Special objectives of the study may be better achieved by using a whole-body mode of exposure, but this should be justified in the study report. To ensure atmosphere stability when using a whole-body chamber, the total volume of the test animals should not exceed 5 % of the chamber volume. Principles of the nose-only and whole body exposure techniques and their particular advantages and disadvantages are addressed in GD 39 (2).

## TOXICITY STUDIES

### Limit Concentrations

10. Unlike with acute studies, there are no defined limit concentrations in subchronic inhalation toxicity studies. The maximum concentration tested should consider: 1) the maximum attainable concentration, 2) the "worst case" human exposure level, 3) the need to maintain an adequate oxygen supply, and/or 4) animal welfare considerations. In the absence of data-based limits, the acute limits of Regulation (EC) No 1272/2008 (13) may be used (i.e. up to a maximum concentration of 5 mg/l for aerosols, 20 mg/l for vapours, and 20 000 ppm for gases); refer to GD 39 (2). Justification should be provided if it is necessary to exceed these limits when testing gases or highly volatile test chemicals (e.g. refrigerants). The limit concentration should elicit unequivocal toxicity without causing undue stress to the animals or affecting their longevity (3).

### Range-Finding Study

11. Before commencing with the main study, it is generally necessary to perform a range-finding study. A range-finding study is more comprehensive than a sighting study because it is not limited to concentration selection. Knowledge learned from a range-finding study can lead to a successful main study. A range-finding study may, for example, provide technical information regarding analytical methods, particle sizing, discovery of toxic mechanisms, clinical pathology and histopathological data, and estimations of what may be NOAEL and MTC concentrations in a main study. The study director may choose to use the range-finding study to identify the threshold of respiratory tract irritation (e.g. with histopathology of the respiratory tract, pulmonary function testing, or bronchoalveolar lavage), the upper concentration which is tolerated without undue stress to the animals, and the parameters that will best characterise a test chemical's toxicity.

12. A range-finding study may consist of one or more concentration levels. Depending on the endpoints chosen, three to six males and three to six females should be exposed at each concentration level. A range-finding study should last a minimum of 5 days and generally no more than 28 days. The rationale for the selection of concentrations for the main study should be provided in the study report. The objective of the main study is to demonstrate a concentration-response relationship based on what is anticipated to be the most sensitive endpoint. The low concentration should ideally be a no-observed-adverse effect concentration while the high concentration should elicit unequivocal toxicity without causing undue stress to the animals or affecting their longevity (3).
13. When selecting concentration levels for the range-finding study, all available information should be considered including structure-activity relationships and data for similar chemicals (see paragraph 3). A range-finding study may verify/refute what are considered to be the most sensitive mechanistically based endpoints, e.g. cholinesterase inhibition by organophosphates, methaemoglobin formation by erythrocytotoxic agents, thyroidal hormones (T<sub>3</sub>, T<sub>4</sub>) for thyrotoxicants, protein, LDH, or neutrophils in bronchoalveolar lavage for innocuous poorly soluble particles or pulmonary irritant aerosols.

#### **Main Study**

14. The main subchronic toxicity study generally consists of three concentration levels, and also concurrent negative (air) and/or vehicle controls as needed (see paragraph 18). All available data should be utilised to aid selection of appropriate exposure levels, including the results of systemic toxicity studies, metabolism and kinetics (particular emphasis should be given to avoiding high concentration levels which saturate kinetic processes). Each test group contains 10 male and 10 female rodents that are exposed to the test chemical for 6 hours per day on a 5 day per week basis for a period of 13 weeks (total study duration of at least 90 days). Animals may also be exposed 7 days per week (e.g. when testing inhaled pharmaceuticals). If one sex is known to be more susceptible to a given test chemical, the sexes may be exposed at different concentration levels in order to optimise the concentration-response as described in paragraph 15. If rodent species other than rats are exposed nose-only, maximum exposure durations may be adjusted to minimise species-specific distress. A rationale should be provided when using an exposure duration less than 6 hours/day, or when it is necessary to conduct a long duration (e.g. 22 hours/day) whole-body exposure study (refer to GD 39) (2). Feed should be withheld during the exposure period unless exposure exceeds 6 hours. Water may be provided throughout a whole-body exposure.
15. The target concentrations selected should identify the target organ(s) and demonstrate a clear concentration-response:
  - The high concentration level should result in toxic effects but not cause lingering signs or lethality which would prevent a meaningful evaluation.
  - The intermediate concentration level(s) should be spaced to produce a gradation of toxic effects between that of the low and high concentration.
  - The low concentration level should produce little or no evidence of toxicity.

#### **Interim Sacrifices**

16. If interim sacrifices are planned, the number of animals at each exposure level should be increased by the number to be sacrificed before study completion. The rationale for using interim sacrifices should be provided, and statistical analyses should properly account for them.

#### **Satellite (Reversibility) Study**

17. A satellite (reversibility) study may be used to observe reversibility, persistence, or delayed occurrence of toxicity for a post-treatment period of an appropriate length, but no less than 14 days. Satellite (reversibility) groups consist of 10 males and 10 females exposed contemporaneously with the experimental animals in the main study. Satellite (reversibility) study groups should be exposed to the test chemical at the highest concentration level and there should be concurrent air and/or vehicle controls as needed (see paragraph 18).

#### **Control Animals**

18. Concurrent negative (air) control animals should be handled in a manner identical to the test group animals except that they are exposed to filtered air rather than test chemical. When water or another substance is used to assist in generating the test atmosphere, a vehicle control group, instead of a negative (air) control group, should be included in the study. Water should be used as the vehicle whenever possible. When water is used as

the vehicle, the control animals should be exposed to air with the same relative humidity as the exposed groups. The selection of a suitable vehicle should be based on an appropriately conducted pre-study or historical data. If a vehicle's toxicity is not well known, the study director may choose to use both a negative (air) control and a vehicle control, but this is strongly discouraged. If historical data reveal that a vehicle is non-toxic, then there is no need for a negative (air) control group and only a vehicle control should be used. If a pre-study of a test chemical formulated in a vehicle reveals no toxicity, it follows that the vehicle is non-toxic at the concentration tested and this vehicle control should be used.

#### EXPOSURE CONDITIONS

##### Administration of Concentrations

19. Animals are exposed to the test chemical as a gas, vapour, aerosol, or a mixture thereof. The physical state to be tested depends on the physico-chemical properties of the test chemical, the selected concentrations, and/or the physical form most likely present during the handling and use of the test chemical. Hygroscopic and chemically reactive test chemicals should be tested under dry air conditions. Care should be taken to avoid generating explosive concentrations. Particulate materials may be subjected to mechanical processes to decrease the particle size. Further guidance is provided in GD 39 (2).

##### Particle-Size Distribution

20. Particle sizing should be performed for all aerosols and for vapours that may condense to form aerosols. To allow for exposure of all relevant regions of the respiratory tract, aerosols with mass median aerodynamic diameters (MMAD) ranging from 1 to 3  $\mu\text{m}$  with a geometric standard deviation ( $\sigma_g$ ) in the range of 1,5 to 3,0 are recommended (4). Although a reasonable effort should be made to meet this standard, expert judgement should be provided if it cannot be achieved. For example, metal fume particles will be smaller than this standard, and charged particles and fibres may exceed it.

##### Test chemical Preparation in a Vehicle

21. Ideally, the test chemical should be tested without a vehicle. If it is necessary to use a vehicle to generate an appropriate test chemical concentration and particle size, water should be given preference. Whenever a test chemical is dissolved in a vehicle, its stability should be demonstrated.

#### MONITORING OF EXPOSURE CONDITIONS

##### Chamber Airflow

22. The flow of air through the exposure chamber should be carefully controlled, continuously monitored, and recorded at least hourly during each exposure. The real-time monitoring of the test atmosphere concentration (or temporal stability) is an integral measurement of all dynamic parameters and provides an indirect means to control all relevant dynamic inhalation parameters. If the concentration is monitored real-time, the frequency of measurement of air flows may be reduced to one single measurement per exposure per day. Special consideration should be given to avoiding rebreathing in nose-only chambers. Oxygen concentration should be at least 19 % and carbon dioxide concentration should not exceed 1 %. If there is reason to believe that this standard cannot be met, oxygen and carbon dioxide concentrations should be measured. If measurements on the first day of exposure show that these gases are at proper levels, no further measurements should be necessary.

##### Chamber Temperature and Relative Humidity

23. Chamber temperature should be maintained at  $22 \pm 3$  °C. Relative humidity in the animals' breathing zone, for both nose-only and whole-body exposures, should be monitored continuously and recorded hourly during each exposure where possible. The relative humidity should preferably be maintained in the range of 30 to 70 %, but this may either be unattainable (e.g. when testing water based mixtures) or not measurable due to test chemical interference with the Test Method.

##### Test chemical: Nominal Concentration

24. Whenever feasible, the nominal exposure chamber concentration should be calculated and recorded. The nominal concentration is the mass of generated test chemical divided by the total volume of air passed through the inhalation chamber system. The nominal concentration is not used to characterise the animals' exposure, but a comparison of the nominal concentration and the actual concentration gives an indication of the generation efficiency of the test system, and thus may be used to discover generation problems.

**Test chemical: Actual Concentration**

25. The actual concentration is the test chemical concentration as sampled at the animals' breathing zone in an inhalation chamber. Actual concentrations can be obtained either by specific methods (e.g. direct sampling, adsorptive or chemical reactive methods, and subsequent analytical characterisation) or by non-specific methods such as gravimetric filter analysis. The use of gravimetric analysis is acceptable only for single component powder aerosols or aerosols of low volatility liquids and should be supported by appropriate pre-study test chemical-specific characterisations. Multi-component powder aerosol concentration may also be determined by gravimetric analysis. However, this requires analytical data which demonstrate that the composition of airborne material is similar to the starting material. If this information is not available, a reanalysis of the test chemical (ideally in its airborne state) at regular intervals during the course of the study may be necessary. For aerosolised agents that may evaporate or sublime, it should be shown that all phases were collected by the method chosen.
26. One lot of the test chemical should be used throughout the duration of the study, if possible, and the test sample should be stored under conditions that maintain its purity, homogeneity, and stability. Prior to the start of the study, there should be a characterisation of the test chemical, including its purity and, if technically feasible, the identity, and quantities of identified contaminants and impurities. This can be demonstrated by, but is not limited to, the following data: retention time and relative peak area, molecular weight from mass spectroscopy or gas chromatography analyses, or other estimates. Although the test sample's identity is not the responsibility of the test laboratory, it may be prudent for the test laboratory to confirm the sponsor's characterisation at least in a limited way (e.g. colour, physical nature, etc.).
27. The exposure atmosphere should be held as constant as practicable. A real-time monitoring device, such as an aerosol photometer for aerosols or a total hydrocarbon analyser for vapours, may be used to demonstrate the stability of the exposure conditions. Actual chamber concentration should be measured at least 3 times during each exposure day for each exposure level. If not feasible due to limited air flow rates or low concentrations, one sample per exposure period is acceptable. Ideally, this sample should then be collected over the entire exposure period. Individual chamber concentration samples should deviate from the mean chamber concentration by no more than  $\pm 10\%$  for gases and vapours, and by no more than  $\pm 20\%$  for liquid or solid aerosols. Time to attain chamber equilibration ( $t_{95}$ ) should be calculated and reported. The duration of an exposure spans the time that the test chemical is generated. This takes into account the times required to attain chamber equilibration ( $t_{95}$ ) and decay. Guidance for estimating  $t_{95}$  can be found in GD 39 (2).
28. For very complex mixtures consisting of gases/vapours and aerosols (e.g. combustion atmospheres and test chemicals propelled from purpose-driven end-use products/devices), each phase may behave differently in an inhalation chamber. Therefore, at least one indicator substance (analyte), normally the principal active ingredient in the mixture, of each phase (gas/vapour and aerosol) should be selected. When the test chemical is a mixture, the analytical concentration should be reported for the total mixture, and not just for the active ingredient or the indicator substance (analyte). Additional information regarding actual concentrations can be found in GD 39 (2).

**Test chemical: Particle Size Distribution**

29. The particle size distribution of aerosols should be determined at least weekly for each concentration level by using a cascade impactor or an alternative instrument such as an aerodynamic particle sizer (APS). If equivalence of the results obtained by a cascade impactor and the alternative instrument can be shown, then the alternative instrument may be used throughout the study.
30. A second device, such as a gravimetric filter or an impinger/gas bubbler, should be used in parallel to the primary instrument to confirm the collection efficiency of the primary instrument. The mass concentration obtained by particle size analysis should be within reasonable limits of the mass concentration obtained by filter analysis [see GD 39 (2)]. If equivalence can be demonstrated at all concentrations tested in the early phase of the study, then further confirmatory measurements may be omitted. For the sake of animal welfare, measures should be taken to minimise inconclusive data which may lead to a need to repeat a study.
31. Particle sizing should be performed for vapours if there is any possibility that vapour condensation may result in the formation of an aerosol, or if particles are detected in a vapour atmosphere with potential for mixed phases.



## OBSERVATIONS

32. The animals should be clinically observed before, during, and after the exposure period. More frequent observations may be indicated depending on the response of the animals during exposure. When animal observation is hindered by the use of animal restraint tubes, poorly lit whole body chambers, or opaque atmospheres, animals should be carefully observed after exposure. Observations before the next day's exposure can assess any reversibility or exacerbation of toxic effects.
33. All observations are recorded with individual records being maintained for each animal. When animals are killed for humane reasons or found dead, the time of death should be recorded as precisely as possible.
34. Cage-side observations should include changes in the skin and fur, eyes, and mucous membranes; changes in the respiratory and circulatory systems; changes in the nervous system; and changes in somatomotor activity and behaviour patterns. Attention should be directed to observations of tremors, convulsions, salivation, diarrhoea, lethargy, sleep, and coma. The measurement of rectal temperatures may provide supportive evidence of reflex bradypnea or hypo/hyperthermia related to treatment or confinement. Additional assessments may be included in the study protocol such as kinetics, biomonitoring, lung function, retention of poorly soluble materials that accumulate in lung tissue, and behavioural changes.

## BODY WEIGHTS

35. Individual animal weights should be recorded shortly before the first exposure (day 0), twice weekly thereafter (for example: on Fridays and Mondays to demonstrate recovery over an exposure-free weekend, or at a time interval to allow assessment of systemic toxicity), and at the time of death or euthanasia. If there are no effects in the first 4 weeks, body weights may be measured weekly for the remainder of the study. Satellite (reversibility) animals (if used) should continue to be weighed weekly throughout the recovery period. At study termination, all animals should be weighed shortly before sacrifice to allow for an unbiased calculated of organ to body weight ratios.

## FOOD AND WATER CONSUMPTION

36. Food consumption should be measured weekly. Water consumption may also be measured.

## CLINICAL PATHOLOGY

37. Clinical pathology assessments should be made for all animals, including controls and satellite (reversibility) animals, when they are sacrificed. The time interval between the end of exposure and blood collection should be recorded, particularly when the reconstitution of the addressed endpoint is rapid. Sampling following the end of exposure is indicated for those parameters with a short plasma half-time (e.g. COHb, CHE, and MetHb).
38. Table 1 lists the clinical pathology parameters that are generally required for all toxicology studies. Urinalysis is not required on a routine basis, but may be performed when deemed useful based on expected or observed toxicity. The study director may choose to assess additional parameters in order to better characterise a test chemical's toxicity (e.g. cholinesterase, lipids, hormones, acid/base balance, methaemoglobin or Heinz bodies, creatine kinase, myeloid/erythroid ratio, troponins, arterial blood gases, lactate dehydrogenase, sorbital dehydrogenase, glutamate dehydrogenase, and gamma glutamyl transpeptidase).

Table 1

## Standard Clinical Pathology Parameters

Haematology	
Erythrocyte count	Total leukocyte count
Haematocrit	Differential leukocyte count
Haemoglobin concentration	Platelet count
Mean corpuscular haemoglobin	Clotting potential (select one):
Mean corpuscular volume	— Prothrombin time
Mean corpuscular haemoglobin concentration	— Clotting time
Reticulocytes	— Partial thromboplastin time



Clinical Chemistry	
Glucose (*)	Alanine aminotransferase
Total cholesterol	Aspartate aminotransferase
Triglycerides	Alkaline phosphatase
Blood urea nitrogen	Potassium
Total bilirubin	Sodium
Creatinine	Calcium
Total protein	Phosphorus
Albumin	Chloride
Globulin	
Urinalysis (optional)	
Appearance (colour and turbidity)	Total protein
Volume	Glucose
Specific gravity or osmolality	Blood/blood cells
pH	

(\*) Because a lengthy fasting period can introduce bias in glucose measurements for the treated versus control animals, the study director should determine whether it is appropriate to fast the animals. If a fasting period is used, it should be appropriate to the species used; for the rat this may be 16 h (overnight fasting). Determination of fasting glucose may be carried out after overnight fasting during the last exposure week, or after overnight fasting prior to necropsy (in the latter case together with all other clinical pathology parameters).

39. When there is evidence that the lower respiratory tract (i.e. the alveoli) is the primary site of deposition and retention, then bronchoalveolar lavage (BAL) may be the technique of choice to quantitatively analyse hypothesis-based dose-effect parameters focusing on alveolitis, pulmonary inflammation, and phospholipidosis. This allows for dose-response and time-course changes of alveolar injury to be suitably probed. The BAL fluid may be analysed for total and differential leukocyte counts, total protein, and lactate dehydrogenase. Other parameters that may be considered are those indicative of lysosomal injury, phospholipidosis, fibrosis, and irritant or allergic inflammation which may include the determination of pro-inflammatory cytokines/chemokines. BAL measurements generally complement the results from histopathology examinations but cannot replace them. Guidance on how to perform lung lavage can be found in GD 39 (2).

#### OPHTHALMOLOGICAL EXAMINATION

40. Using an ophthalmoscope or an equivalent device, ophthalmological examinations of the fundus, refractive media, iris, and conjunctivae should be performed for all animals prior to the administration of the test chemical, and for all high concentration and control groups at termination. If changes in the eyes are detected, all animals in the other groups should be examined including the satellite (reversibility) group.

#### GROSS PATHOLOGY AND ORGAN WEIGHTS

41. All test animals, including those which die during the test or are removed from the study for animal welfare reasons, should be subjected to complete exsanguination (if feasible) and gross necropsy. The time between the end of each animal's last exposure and its sacrifice should be recorded. If a necropsy cannot be performed immediately after a dead animal is discovered, the animal should be refrigerated (not frozen) at a temperature low enough to minimise autolysis. Necropsies should be performed as soon as possible, normally within a day or two. All gross pathological changes should be recorded for each animal with particular attention to any changes in the respiratory tract.
42. Table 2 lists the organs and tissues that should be preserved in a suitable medium during gross necropsy for histopathological examination. The preservation of the [bracketed] organs and tissues and any other organs and tissues is at the discretion of the study director. The **bolded** organs should be trimmed and weighed wet as soon as possible after dissection to avoid drying. The thyroid and epididymides should only be weighed if needed because trimming artefacts may hinder histopathological evaluation. Tissues and organs should be fixed in 10 % buffered formalin or another suitable fixative as soon as necropsy is performed, and no less than 24-48 hours prior to trimming depending on the fixative to be used.

Table 2

**Organs and Tissues Preserved During Gross Necropsy**

<b>Adrenals</b>	Oesophagus
Aorta	[Olfactory bulb]
Bone marrow (and/or fresh aspirate)	<b>Ovaries</b>
<b>Brain</b> (including sections of cerebrum, cerebellum, and medulla/pons)	Pancreas
Caecum	Parathyroids
Colon	Peripheral nerve (sciatic or tibial, preferably close to muscle)
Duodenum	Pituitary
<b>[Epididymides]</b>	Prostate
[Eyes (retina, optic nerve) and eyelids]	Rectum
Femur and stifle joint	Salivary glands
Gallbladder (where present)	Seminal vesicles
[Harderian glands]	Skin
<b>Heart</b>	Spinal cord (cervical, mid-thoracic, and lumbar)
Ileum	<b>Spleen</b>
Jejunum	Sternum
<b>Kidneys</b>	Stomach
[Lacrimal glands (extraorbital)]	Teeth
Larynx (3 levels including the base of the epiglottis)	<b>Testes</b>
<b>Liver</b>	<b>Thymus</b>
<b>Lung</b> (all lobes at one level, including main bronchi)	<b>Thyroids</b>
Lymph nodes from the hilar region of the lung, especially for poorly soluble particulate test chemicals. For more in depth examinations and/or studies with immunological focus, additional lymph nodes may be considered, e.g. those from the mediastinal, cervical/submandibular and/or auricular regions.	[Tongue]
Lymph nodes (distal from the portal-of-entry)	Trachea (at least 2 levels including 1 longitudinal section through the carina and 1 transverse section)
Mammary gland (female)	[Ureter]
Muscle (thigh)	[Urethra]
Nasopharyngeal tissues (at least 4 levels; 1 level to include the nasopharyngeal duct and the Nasal Associated Lymphoid Tissue (NALT))	Urinary bladder
	<b>Uterus</b>
	Target organs
	All gross lesions and masses

43. The lungs should be removed intact, weighed, and instilled with a suitable fixative at a pressure of 20-30 cm of water to ensure that lung structure is maintained (5). Sections should be collected for all lobes at one level, including main bronchi, but if lung lavage is performed, the unlavaged lobe should be sectioned at three levels (not serial sections).

44. At least 4 levels of the nasopharyngeal tissues should be examined, one of which should include the nasopharyngeal duct (5) (6) (7) (8) (9) to allow adequate examination of the squamous, transitional (non-ciliated respiratory), respiratory (ciliated respiratory) and olfactory epithelium, and the draining lymphatic tissue (NALT) (10) (11). Three levels of the larynx should be examined, and one of these levels should include the base of the epiglottis (12). At least two levels of the trachea should be examined including one longitudinal section through the carina of the bifurcation of the extrapulmonary bronchi and one transverse section.

#### HISTOPATHOLOGY

45. A histopathological evaluation of all the organs and tissues listed in Table 2 should be performed for the control and high concentration groups, and for all animals which die or are sacrificed during the study. Particular attention should be paid to the respiratory tract, target organs, and gross lesions. The organs and tissues that have lesions in the high concentration group should be examined in all groups. The study director may choose to perform histopathological evaluations for additional groups to demonstrate a clear concentration response. When a satellite (reversibility) group is used, histopathological evaluation should be performed for all tissues and organs identified as showing effects in the treated groups. If there are excessive early deaths or other problems in the high exposure group that compromise the significance of the data, the next lower concentration should be examined histopathologically. An attempt should be made to correlate gross observations with microscopic findings.

#### DATA AND REPORTING

##### Data

46. Individual animal data on body weights, food consumption, clinical pathology, gross pathology, organ weights, and histopathology should be provided. Clinical observation data should be summarised in tabular form showing for each test group the number of animals used, the number of animals displaying specific signs of toxicity, the number of animals found dead during the test or killed for humane reasons, time of death of individual animals, a description and time course of toxic effects and reversibility, and necropsy findings. All results, quantitative and incidental, should be evaluated by an appropriate statistical method. Any generally accepted statistical method may be used and the statistical methods should be selected during the design of the study.

##### Test Report

47. The test report should include the following information, as appropriate:

##### *Test animals and husbandry*

- Description of caging conditions, including: number (or change in number) of animals per cage, bedding material, ambient temperature and relative humidity, photoperiod, and identification of diet.
- Species/strain used and justification for using a species other than the rat. Source and historical data may be provided, if they are for animals exposed under similar exposure, housing, and fasting conditions.
- Number, age, and sex of animals.
- Method of randomisation.
- Description of any pre-test conditioning including diet, quarantine, and treatment for disease.

##### *Test chemical*

- Physical nature, purity, and, where relevant, physico-chemical properties (including isomerisation).
- Identification data and Chemical Abstract Services (CAS) Registry Number, if known.

##### *Vehicle*

- Justification for use of vehicle and justification for choice of vehicle (if other than water).
- Historical or concurrent data demonstrating that the vehicle does not interfere with the outcome of the study.

*Inhalation chamber*

- Detailed description of the inhalation chamber including volume and a diagram.
- Source and description of equipment used for the exposure of animals as well as generation of atmosphere.
- Equipment for measuring temperature, humidity, particle-size, and actual concentration.
- Source of air and system used for conditioning.
- Methods used for calibration of equipment to ensure a homogeneous test atmosphere.
- Pressure difference (positive or negative).
- Exposure ports per chamber (nose-only); location of animals in the chamber (whole-body).
- Stability of the test atmosphere.
- Location of temperature and humidity sensors and sampling of test atmosphere in the chamber.
- Treatment of air supplied/extracted.
- Air flow rates, air flow rate/exposure port (nose-only), or animal load/chamber (whole-body).
- Time to inhalation chamber equilibrium ( $t_{95}$ ).
- Number of volume changes per hour.
- Metering devices (if applicable).

*Exposure data*

- Rationale for target concentration selection in the main study.
- Nominal concentrations (total mass of test chemical generated into the inhalation chamber divided by the volume of air passed through the chamber).
- Actual test chemical concentrations collected from the animals' breathing zone; for mixtures that produce heterogeneous physical forms (gases, vapours, aerosols), each may be analysed separately.
- All air concentrations should be reported in units of mass (mg/l, mg/m<sup>3</sup>, etc.) rather than in units of volume (ppm, ppb, etc.).
- Particle size distribution, mass median aerodynamic diameter (MMAD), and geometric standard deviation ( $\sigma_g$ ), including their methods of calculation. Individual particle size analyses should be reported.

*Test conditions*

- Details of test chemical preparation, including details of any procedures used to reduce the particle size of solid materials or to prepare solutions of the test chemical.
- A description (preferably including a diagram) of the equipment used to generate the test atmosphere and to expose the animals to the test atmosphere.
- Details of the equipment used to monitor chamber temperature, humidity, and chamber airflow (i.e. development of a calibration curve).
- Details of the equipment used to collect samples for determination of chamber concentration and particle size distribution.
- Details of the chemical analytical method used and method validation (including efficiency of recovery of test chemical from the sampling medium).

- Method of randomisation in assigning animals to test and control groups.
- Details of food and water quality (including diet type/source, water source).
- The rationale for the selection of test concentrations.

#### *Results*

- Tabulation of chamber temperature, humidity, and airflow.
- Tabulation of chamber nominal and actual concentration data.
- Tabulation of particle size data including analytical sample collection data, particle size distribution, and calculations of the MMAD and  $\sigma_g$ .
- Tabulation of response data and concentration level for each animal (i.e. animals showing signs of toxicity including mortality, nature, severity, time of onset, and duration of effects).
- Tabulation of individual animal weights.
- Tabulation of food consumption
- Tabulation of clinical pathology data
- Necropsy findings and histopathological findings for each animal, if available.

#### *Discussion and interpretation of results*

- Particular emphasis should be made to the description of methods used to meet the criteria of this Test Method, e.g. the limit concentration or the particle size.
- The respirability of particles in light of the overall findings should be addressed, especially if the particle-size criteria could not be met.
- The consistency of methods used to determine nominal and actual concentrations, and the relation of actual concentration to nominal concentration should be included in the overall assessment of the study.
- The likely cause of death and predominant mode of action (systemic versus local) should be addressed.
- An explanation should be provided if there was a need to humanely sacrifice animals in pain or showing signs of severe and enduring distress, based on the criteria in the OECD Guidance Document on Humane Endpoints (3).
- The target organ(s) should be identified.
- The NOAEL and LOAEL should be determined.

#### *LITERATURE:*

- (1) OECD (1981). *Subchronic Inhalation Toxicity Testing*, Original Test Guideline No 413, Environment Directorate, OECD, Paris.
- (2) OECD (2009). *Guidance Document on Acute Inhalation Toxicity Testing*, Environmental Health and Safety Monograph Series on Testing and Assessment No 39, ENV/JM/MONO(2009)28, OECD, Paris.
- (3) OECD (2000). *Guidance Document on the Recognition, Assessment and Use of Clinical Signs as Humane Endpoints for Experimental Animals Used in Safety Evaluation*, Environmental Health and Safety Monograph Series on Testing and Assessment No 19, ENV/JM/MONO(2000)7, OECD, Paris.
- (4) Whalan.E and Redden JC (1994). *Interim Policy for Particle Size and Limit Concentration Issues in Inhalation Toxicity Studies*. Office of Pesticide Programs, United States Environmental Protection Agency.

- 
- (5) Dungworth DL, Tyler WS, Plopper CE (1985). Morphological Methods for Gross and Microscopic Pathology (Chapter 9) in *Toxicology of Inhaled Material*, Witschi, H.P. and Brain, J.D. (eds), Springer Verlag Heidelberg, pp. 229-258.
  - (6) Young JT (1981). Histopathological examination of the rat nasal cavity. *Fundam. Appl. Toxicol.* 1: 309-312.
  - (7) Harkema JR (1990). Comparative pathology of the nasal mucosa in laboratory animals exposed to inhaled irritants. *Environ. Health Perspect.* 85: 231-238.
  - (8) Woutersen RA, Garderen-Hoetmer A, van Slootweg PJ, Feron VJ (1994). Upper respiratory tract carcinogenesis in experimental animals and in humans. In: Waalkes MP and Ward JM (eds) *Carcinogenesis. Target Organ Toxicology Series*, Raven Press, New York, 215-263.
  - (9) Mery S, Gross EA, Joyner DR, Godo M, Morgan KT (1994). Nasal diagrams: A tool for recording the distribution of nasal lesions in rats and mice. *Toxicol. Pathol.* 22: 353-372.
  - (10) Kuper CF, Koornstra PJ, Hameleers DMH, Biewenga J, Spit BJ, Duijvestijn AM, Breda Vriesman van PJC, Sminia T (1992). The role of nasopharyngeal lymphoid tissue. *Immunol. Today* 13: 219-224.
  - (11) Kuper CF, Arts JHE, Feron VJ (2003). Toxicity to nasal-associated lymphoid tissue. *Toxicol. Lett.* 140-141: 281-285.
  - (12) Lewis DJ (1981). Mitotic Indices of Rat Laryngeal Epithelia. *Journal of Anatomy* 132(3): 419-428.
  - (13) Regulation (EC) No 1272/2008 of the European Parliament and of the Council of 16 December 2008 on classification, labelling and packaging of substances and mixtures, amending and repealing Directives 67/548/EEC and 1999/45/EC, and amending Regulation (EC) No 1907/2006 (OJ L 353, 31.12.2008, p. 1).
-

## Appendix 1

## DEFINITION

**Test chemical:** Any substance or mixture tested using this Test Method.

## B.30. CHRONIC TOXICITY STUDIES

## INTRODUCTION

1. This Test Method is equivalent to OECD Test Guideline (TG) 452 (2009). The original TG 452 was adopted in 1981. Development of this revised Test Method B.30 was considered necessary in order to reflect recent developments in the field of animal welfare and regulatory requirements (1) (2) (3) (4). The updating of this Test Method B.30 has been carried out in parallel with revisions of Chapter B.32 of this Annex, Carcinogenicity Studies, and Chapter B.33 of this Annex, Combined Chronic Toxicity/Carcinogenicity studies, with the objective of obtaining additional information from the animals used in the study and providing further detail on dose selection. This Test Method is designed to be used in the testing of a broad range of chemicals, including pesticides and industrial chemicals.
2. The majority of chronic toxicity studies are carried out in rodent species, and this Test Method is intended therefore to apply primarily to studies carried out in these species. Should such studies be required in non-rodent species, the principles and procedures outlined in this Test Method, together with those outlined in Chapter B.27 of this Annex, Repeated Dose 90-day Oral Toxicity Study in Non-Rodents (5), may also be applied, with appropriate modifications, as outlined in the OECD Guidance Document No 116 on the Design and Conduct of Chronic Toxicity and Carcinogenicity Studies (6).
3. The three main routes of administration used in chronic toxicity studies are oral, dermal and inhalation. The choice of the route of administration depends on the physical and chemical characteristics of the test chemical and the predominant route of exposure of humans. Additional information on choice of route of exposure is provided in the OECD Guidance Document No 116 (6).
4. This Test Method focuses on exposure via the oral route, the route most commonly used in chronic toxicity studies. While long-term chronic toxicity studies involving exposure via the dermal or inhalation routes may also be necessary for human health risk assessment and/or may be required under certain regulatory regimes, both routes of exposure involve considerable technical complexity. Such studies will need to be designed on a case-by-case basis, although the Test Method outlined here for the assessment and evaluation of chronic toxicity by oral administration could form the basis of a protocol for inhalation and/or dermal studies, with respect to recommendations for treatment periods, clinical and pathology parameters, etc. OECD Guidance is available on the administration of test chemicals by the inhalation (6) (7) and dermal routes (6). Chapter B.8 of this Annex (8) and Chapter B.29 of this Annex (9), together with the OECD Guidance Document on acute inhalation testing (7), should be specifically consulted in the design of longer term studies involving exposure via the inhalation route. Chapter B.9 of this Annex (10) should be consulted in the case of testing carried out by the dermal route.
5. The chronic toxicity study provides information on the possible health hazards likely to arise from repeated exposure over a considerable part of the lifespan of the species used. The study will provide information on the toxic effects of the test chemical; indicate target organs and the possibility of accumulation. It can also provide an estimate of the no-observed-adverse effect level which can be used for establishing safety criteria for human exposure. The need for careful clinical observations of the animals, so as to obtain as much information as possible, is also stressed.
6. The objectives of studies covered by this Test Method include:
  - The identification of the chronic toxicity of a test chemical;
  - The identification of target organs;
  - Characterisation of the dose-response relationship;
  - Identification of a no-observed-adverse-effect level (NOAEL) or point of departure for establishment of a Benchmark Dose (BMD);
  - The prediction of chronic toxicity effects at human exposure levels;
  - Provision of data to test hypotheses regarding mode of action (6).

## INITIAL CONSIDERATIONS

7. In the assessment and evaluation of the toxicological characteristics of a test chemical, all available information on the test chemical should be considered by the testing laboratory prior to conducting the study, in order to focus the design of the study to more efficiently test for chronic toxicity potential and to minimize animal usage. Information that will assist in the study design includes the identity, chemical structure, and physico-chemical properties of the test chemical; any information on the mode of action; results of any *in vitro* or *in vivo* toxicity tests; anticipated use(s) and potential for human exposure; available (Q)SAR data and toxicological data on structurally-related chemicals; available toxicokinetic data (single dose and also repeat dose kinetics where available) and data derived from other repeated exposure studies. The determination of chronic toxicity should only be carried out after initial information on toxicity has been obtained from repeated dose 28-day and/or 90-day toxicity tests. A phased testing approach to chronic toxicity testing should be considered as part of the overall assessment of the potential adverse health effects of a particular test chemical (11) (12) (13) (14).
8. The statistical methods most appropriate for the analysis of results, given the experimental design and objectives, should be established before commencing the study. Issues to consider include whether the statistics should include adjustment for survival and analysis in the event of premature termination of one or more groups. Guidance on the appropriate statistical analyses and key references to internationally accepted statistical methods are given in Guidance Document No 116 (6), and also in Guidance Document No 35 on the analysis and evaluation of chronic toxicity and carcinogenicity studies (15).
9. In conducting a chronic toxicity study, the guiding principles and considerations outlined in the OECD Guidance Document No 19 on the recognition, assessment, and use of clinical signs as humane endpoints for experimental animals used in safety evaluation (16), in particular paragraph 62 thereof, should always be followed. This paragraph states that *"In studies involving repeated dosing, when an animal shows clinical signs that are progressive, leading to further deterioration in condition, an informed decision as to whether or not to humanely kill the animal should be made. The decision should include consideration as to the value of the information to be gained from the continued maintenance of that animal on study relative to its overall condition. If a decision is made to leave the animal on test, the frequency of observations should be increased, as needed. It may also be possible, without adversely affecting the purpose of the test, to temporarily stop dosing if it will relieve the pain or distress, or reduce the test dose."*
10. Detailed guidance on and discussion of the principles of dose selection for chronic toxicity and carcinogenicity studies can be found in Guidance Document No 116 (6), as well as two International Life Sciences Institute publications (17) (18). The core dose selection strategy is dependent on the primary objective or objectives of the study (paragraph 6). In selecting appropriate dose levels, a balance should be achieved between hazard screening on the one hand and characterisation of low-dose responses and their relevance on the other. This is particularly relevant in the situation where a combined chronic toxicity and carcinogenicity study (Chapter B.33 of this Annex) is to be carried out (paragraph 11).
11. Consideration should be given to carrying out a combined chronic toxicity and carcinogenicity study (Chapter B.33 of this Annex), rather than separate execution of a chronic toxicity study (this Test Method B.30) and carcinogenicity study (Chapter B.32 of this Annex). The combined test provides greater efficiency in terms of time and cost compared to conducting two separate studies, without compromising the quality of the data in either the chronic phase or the carcinogenicity phase. Careful consideration should however be given to the principles of dose selection (paragraphs 9 and 20-25) when undertaking a combined chronic toxicity and carcinogenicity study (Chapter B.33 of this Annex), and it is also recognised that separate studies may be required under certain regulatory frameworks.
12. Definitions used in the context of this Test Method can be found at the end of this chapter and in the Guidance Document No 116 (6).

## PRINCIPLE OF THE TEST

13. The test chemical is administered daily in graduated doses to several groups of experimental animals, normally for a period of 12 months, although longer or shorter durations may also be chosen depending on regulatory requirements (see paragraph 33). This duration is chosen to be sufficiently long to allow any effects of cumulative toxicity to become manifest, without the confounding effects of geriatric changes. Deviations from exposure duration of 12 months should be justified, particularly in the case of shorter durations. The test chemical is normally administered by the oral route although testing by the inhalation or dermal route may also be appropriate. The study design may also include one or more interim kills, e.g. at 3 and 6 months, and additional groups of animals may be included to accommodate this (see paragraph 19). During the period of administration the animals are observed closely for signs of toxicity. Animals which die or are killed during the test are necropsied and, at the conclusion of the test, surviving animals are killed and necropsied.



## DESCRIPTION OF THE METHOD

### Selection of animal species

14. This Test Method primarily covers assessment and evaluation of chronic toxicity in rodents (see paragraph 2) although it is recognised that similar studies in non-rodents may be required under certain regulatory regimes. The choice of species should be justified. The design and conduct of chronic toxicity studies in non-rodent species, when required, should be based on the principles outlined in this Test Method together with those in Chapter B.27 of this Annex, Repeated Dose 90-day Oral Toxicity Study in Non-Rodents (5). Additional information on choice of species and strain is provided in Guidance Document No 116 (6).
  
15. In this Test Method, the preferred rodent species is the rat, although other rodent species, e.g. the mouse, may be used. Rats and mice have been preferred experimental models because of their relatively short life span, their widespread use in pharmacological and toxicological studies, their susceptibility to tumour induction, and the availability of sufficiently characterised strains. As a consequence of these characteristics, a large amount of information is available on their physiology and pathology. Young healthy adult animals of commonly used laboratory strains should be employed. The chronic toxicity study should be carried out in animals from the same strain and source as those used in preliminary toxicity study(ies) of shorter duration. The females should be nulliparous and non-pregnant.

### Housing and feeding conditions

16. Animals may be housed individually, or be caged in small groups of the same sex; individual housing should be considered only if scientifically justified (19) (20) (21). Cages should be arranged in such a way that possible effects due to cage placement are minimised. The temperature in the experimental animal room should be 22 °C ( $\pm$  3 °C). Although the relative humidity should be at least 30 % and preferably not exceed 70 % other than during room cleaning, the aim should be 50-60 %. Lighting should be artificial, the sequence being 12 hours light, 12 hours dark. For feeding, conventional laboratory diets may be used with an unlimited supply of drinking water. The diet should meet all the nutritional requirements of the species tested and the content of dietary contaminants including but not limited to pesticide residues, persistent organic pollutants, phytoestrogens, heavy metals and mycotoxins, that might influence the outcome of the test, should be as low as possible. Analytical information on the nutrient and dietary contaminant levels should be generated periodically, at least at the beginning of the study and when there is a change in the batch used, and should be included in the final report. Analytical information on the drinking water used in the study should similarly be provided. The choice of diet may be influenced by the need to ensure a suitable admixture of a test chemical and to meet the nutritional requirements of the animals when the test chemical is administered by the dietary route.

### Preparation of animals

17. Healthy animals, which have been acclimated to laboratory conditions for at least 7 days and have not been subjected to previous experimental procedures, should be used. In the case of rodents, dosing of the animals should begin as soon as possible after weaning and acclimatisation and preferably before the animals are 8 weeks old. The test animals should be characterised as to species, strain, source, sex, weight and age. At the commencement of the study, the weight variation for each sex of animals used should be minimal and not exceed  $\pm$  20 % of the mean weight of all the animals within the study, separately for each sex. Animals should be randomly assigned to the control and treatment groups. After randomisation, there should be no significant differences in mean body weights between groups within each sex. If there are statistically significant differences, then the randomisation step should be repeated, if possible. Each animal should be assigned a unique identification number, and permanently marked with this number by tattooing, microchip implant, or other suitable method.

## PROCEDURE

### Number and sex of animals

18. Both sexes should be used. A sufficient number of animals should be used so that at the end of the study enough animals in every group are available for thorough biological and statistical evaluation. For rodents, at least 20 animals per sex per group should normally be used at each dose level, while for non-rodents a minimum of 4 per sex per group is recommended. In studies involving mice, additional animals may be needed in each dose group to conduct all required haematological determinations.

### Provision for interim kills, satellite groups and sentinel animals

19. The study may make provision for interim kills (at least 10 animals/sex/group), e.g. at 6 months, to provide information on progression of toxicological changes and mechanistic information, if scientifically justified. Where such information is already available from previous repeat dose toxicity studies on the test chemical, interim kills may not be scientifically justified. Satellite groups may also be included to monitor the reversibility of any toxicological changes induced by the test chemical under investigation; these will normally be restricted

to the highest dose level of the study plus control. An additional group of sentinel animals (typically 5 animals per sex) may also be included for monitoring of disease status, if necessary, during the study (22). If interim kills or inclusion of satellite or sentinel groups are planned, the number of animals included in the study design should be increased by the number of animals scheduled to be killed before the completion of the study. These animals should normally undergo the same observations, including body weight, food/water consumption, haematological and clinical biochemistry measurements and pathological investigations as the animals in the chronic toxicity phase of the main study, although provision may also be made (in the interim kill groups) for measurements to be restricted to specific, key measures such as neurotoxicity or immunotoxicity.

#### **Dose groups and dosage**

20. Guidance on all aspects of dose selection and dose level spacing is provided in Guidance Document No 116 (6). At least three dose levels and a concurrent control should be used, except where a limit test is conducted (see paragraph 27). Dose levels will generally be based on the results of shorter-term repeated dose or range finding studies and should take into account any existing toxicological and toxicokinetic data available for the test chemical or related chemicals.
21. Unless limited by the physical-chemical nature or biological effects of the test chemical, the highest dose level should normally be chosen to identify the principal target organs and toxic effects while avoiding suffering, severe toxicity, morbidity, or death. While taking into account the factors outlined in paragraph 22 below, the highest dose level should be chosen to elicit evidence of toxicity, as evidenced by, for example, depression of body weight gain (approximately 10 %).
22. However, dependent on the objectives of the study (see paragraph 6), a top dose lower than the dose providing evidence of toxicity may be chosen, e.g. if a dose elicits an adverse effect of concern that nonetheless has little impact on lifespan or body weight. The top dose should not exceed 1 000 mg/kg body weight/day (limit dose, see paragraph 27).
23. Dose levels and dose level spacing may be selected to establish a dose-response and a NOAEL or other intended outcome of the study, e.g. a BMD (see paragraph 25) at the lowest dose level. Factors that should be considered in the placement of lower doses include the expected slope of the dose-response curve, the doses at which important changes may occur in metabolism or mode of toxic action, where a threshold is expected, or where a point of departure for low-dose extrapolation is expected.
24. The dose level spacing selected will depend on the characteristics of the test chemical, and cannot be prescribed in this Test Method, but two to four fold intervals frequently provide good test performance when used for setting the descending dose levels and addition of a fourth test group is often preferable to using very large intervals (e.g. more than a factor of about 6-10) between dosages. In general the use of factors greater than 10 should be avoided, and should be justified if used.
25. As outlined further in Guidance Document No 116 (6), points to be considered in dose selection include:
  - Known or suspected nonlinearities or inflection points in the dose-response;
  - Toxicokinetics, and dose ranges where metabolic induction, saturation, or nonlinearity between external and internal doses does or does not occur;
  - Precursor lesions, markers of effect, or indicators of the operation of key underlying biological processes;
  - Key (or suspected) aspects of mode of action, such as doses at which cytotoxicity begins to arise, hormone levels are perturbed, homeostatic mechanisms are overwhelmed, etc.;
  - Regions of the dose-response curve where particularly robust estimation is needed, e.g. in the range of the anticipated BMD or a suspected threshold;
  - Consideration of anticipated human exposure levels.
26. The control group shall be an untreated group or a vehicle-control group if a vehicle is used in administering the test chemical. Except for treatment with the test chemical, animals in the control group should be handled in an identical manner to those in the test groups. If a vehicle is used, the control group shall receive the vehicle in the highest volume used among the dose groups. If a test chemical is administered in the diet, and causes significantly reduced dietary intake due to the reduced palatability of the diet, an additional pair-fed control group may be useful, to serve as a more suitable control.

27. If it can be anticipated, based on information from preliminary studies, that a test at one dose level, equivalent to at least 1 000 mg/kg body weight/day, using the procedures described for this study, is unlikely to produce adverse effects and if toxicity would not be expected based upon data from structurally related chemicals, then a full study using three dose levels may not be considered necessary. A limit of 1 000 mg/kg body weight/day may apply except when human exposure indicates the need for a higher dose level to be used.

#### **Preparation of doses and administration of test chemical**

28. The test chemical is normally administered orally, via the diet or drinking water, or by gavage. Additional information on routes and methods of administration is provided in Guidance Document No 116 (6). The route and method of administration is dependent on the purpose of the study, the physical/chemical properties of the test chemical, its bioavailability and the predominant route and method of exposure of humans. A rationale should be provided for the chosen route and method of administration. In the interests of animal welfare, oral gavage should normally be selected only for those agents for which this route and method of administration reasonably represent potential human exposure (e.g. pharmaceuticals). For dietary or environmental chemicals including pesticides, administration is typically via the diet or drinking water. However, for some scenarios, e.g. occupational exposure, administration via other routes may be more appropriate.
29. Where necessary, the test chemical is dissolved or suspended in a suitable vehicle. Consideration should be given to the following characteristics of the vehicle and other additives, as appropriate: effects on the absorption, distribution, metabolism, or retention of the test chemical; effects on the chemical properties of the test chemical which may alter its toxic characteristics; and effects on the food or water consumption or the nutritional status of the animals. It is recommended that, wherever possible, the use of an aqueous solution/suspension be considered first, followed by consideration of a solution/emulsion in oil (e.g. corn oil) and then by possible solution in other vehicles. For vehicles other than water, the toxic characteristics of the vehicle should be known. Information should be available on the stability of the test chemical and the homogeneity of dosing solutions or diets (as appropriate) under the conditions of administration (e.g. diet).
30. For chemicals administered via the diet or drinking water it is important to ensure that the quantities of the test chemical involved do not interfere with normal nutrition or water balance. In long-term toxicity studies using dietary administration, the concentration of the test chemical in the feed should not normally exceed an upper limit of 5 % of the total diet, in order to avoid nutritional imbalances. When the test chemical is administered in the diet, either a constant dietary concentration (mg/kg diet or ppm) or a constant dose level in terms of the animal's body weight (mg/kg body weight), calculated on a weekly basis, may be used. The alternative used should be specified.
31. In the case of oral administration, the animals are dosed with the test chemical daily (seven days each week), normally for a period of 12 months (see also paragraph 33), although a longer duration may be required depending on regulatory requirements. Any other dosing regime, e.g. five days per week, needs to be justified. In the case of dermal administration, animals are normally treated with the test chemical for at least 6 hours per day, 7 days per week, as specified in Chapter B.9 of this Annex (10), for a period of 12 months. Exposure by the inhalation route is carried out for 6 hours per day, 7 days per week, but exposure for 5 days per week may also be used, if justified. The period of exposure will normally be for a period of 12 months. If rodent species other than rats are exposed nose-only, maximum exposure durations may be adjusted to minimise species-specific distress. A rationale should be provided when using an exposure duration of less than 6 hours per day. See also Chapter B.8 of this Annex (8).
32. When the test chemical is administered by gavage to the animals this should be done using a stomach tube or a suitable intubation cannula, at similar times each day. Normally a single dose will be administered once daily, where for example a chemical is a local irritant, it may be possible to maintain the daily dose-rate by administering it as a split dose (twice a day). The maximum volume of liquid that can be administered at one time depends on the size of the test animal. The volume should be kept as low as practical, and should not normally exceed 1 ml/100 g body weight for rodents (22). Variability in test volume should be minimised by adjusting the concentration to ensure a constant volume at all dose levels. Potentially corrosive or irritant chemicals are the exception, and need to be diluted to avoid severe local effects. Testing at concentrations that are likely to be corrosive or irritant to the gastrointestinal tract should be avoided.

#### **Duration of study**

33. While this Test Method primarily is designed as a 12 month chronic toxicity study, the study design also allows for and can be applied to either shorter (e.g. 6 or 9 months) or longer (e.g. 18 or 24 months) duration studies, depending on the requirements of particular regulatory regimes or for specific mechanistic purposes. Deviations from an exposure duration of 12 months should be justified, particularly in the case of shorter durations. Satellite groups included to monitor the reversibility of any toxicological changes induced by the test chemical under investigation should be maintained without dosing for a period not less than 4 weeks and not more than one third of the total study duration after cessation of exposure. Further guidance, including consideration of survival in the study, is provided in Guidance Document No 116 (6).

#### OBSERVATIONS

34. All animals should be checked for morbidity or mortality, usually at the beginning and end of each day, including at weekends and holidays. General clinical observations should be made at least once a day, preferably at the same time(s) each day, taking into consideration the peak period of anticipated effects after dosing in the case of gavage administration.
35. Detailed clinical observations should be made on all animals at least once prior to the first exposure (to allow for within-subject comparisons), at the end of the first week of the study and monthly thereafter. The protocol for observations should be arranged such that variations between individual observers are minimised and independent of test group. These observations should be made outside the home cage, preferably in a standard arena and at similar times on each occasion. They should be carefully recorded, preferably using scoring systems, explicitly defined by the testing laboratory. Efforts should be made to ensure that variations in the observation conditions are minimal. Signs noted should include, but not be limited to, changes in skin, fur, eyes, mucous membranes, occurrence of secretions and excretions and autonomic activity (e.g. lacrimation, piloerection, pupil size, and unusual respiratory pattern). Changes in gait, posture and response to handling as well as the presence of clonic or tonic movements, stereotypies (e.g. excessive grooming, repetitive circling) or bizarre behaviour (e.g. self-mutilation, walking backwards) should also be recorded (24).
36. Ophthalmological examination, using an ophthalmoscope or other suitable equipment, should be carried out on all animals prior to the first administration of the test chemical. At the termination of the study, this examination should be preferably conducted in all animals but at least in the high dose and control groups. If treatment-related changes in the eyes are detected, all animals should be examined. If structural analysis or other information suggests ocular toxicity, then the frequency of ocular examination should be increased.
37. For chemicals where previous repeated dose 28-day and/or 90-day toxicity tests indicated the potential to cause neurotoxic effects, sensory reactivity to stimuli of different types (24) (e.g. auditory, visual and proprioceptive stimuli) (25), (26), (27), assessment of grip strength (28) and motor activity assessment (29) may optionally be conducted before commencement of the study and at 3 month periods after study initiation up to and including 12 months, as well as at study termination (if longer than 12 months). Further details of the procedures that could be followed are given in the respective references. However, alternative procedures than those referenced could also be used.
38. For chemicals where previous repeated dose 28-day and/or 90-day toxicity tests indicated the potential to cause immunotoxic effects, further investigations of this endpoint may optionally be conducted at termination.

#### **Body weight, food/water consumption and food efficiency**

39. All animals should be weighed at the start of treatment, at least once a week for the first 13 weeks, and at least monthly thereafter. Measurements of food consumption and food efficiency should be made at least weekly for the first 13 weeks and at least monthly thereafter. Water consumption should be measured at least weekly for the first 13 weeks and at least monthly thereafter when the chemical is administered in drinking water. Water consumption measurements should also be considered for studies in which drinking activity is altered.

#### **Haematology and clinical biochemistry**

40. In studies involving rodents, haematological examinations should be carried out in at least 10 male and 10 female animals per group, at 3, 6, and 12 months, as well as at study termination (if longer than 12 months), using the same animals throughout. In mice, satellite animals may be needed in order to conduct all required haematological determinations (see paragraph 18). In non-rodent studies, samples will be taken from smaller numbers of animals (e.g. 4 animals per sex and per group in dog studies), at interim sampling times and at termination as described for rodents. Measurements at 3 months, either in rodents or non-rodents, need not be conducted if no effect was seen on haematological parameters in a previous 90 day study carried out at comparable dose levels. Blood samples should be taken from a named site, for example by cardiac puncture or from the retro-orbital sinus, under anaesthesia.
41. The following list of parameters should be investigated (30): Total and differential leukocyte count, erythrocyte count, platelet count, haemoglobin concentration, haematocrit (packed cell volume), mean corpuscular volume (MCV), mean corpuscular haemoglobin (MCH), mean corpuscular haemoglobin concentration (MCHC), prothrombin time, and activated partial thromboplastin time. Other hematology parameters such as Heinz bodies or other atypical erythrocyte morphology or methaemoglobin may be measured as appropriate depending on the toxicity of the test chemical. Overall, a flexible approach should be adopted, depending on the observed and/or expected effect from a given test chemical. If the test chemical has an effect on the haematopoietic system, reticulocyte counts and bone marrow cytology may also be indicated, although these need not be routinely conducted.

42. Clinical biochemistry determinations to investigate major toxic effects in tissues and, specifically, effects on kidney and liver, should be performed on blood samples obtained from at least 10 male and 10 female animals per group at the same time intervals as specified for the haematological investigations, using the same animals throughout. In mice, satellite animals may be needed in order to conduct all required clinical biochemistry determinations. In non-rodent studies, samples will be taken from smaller numbers of animals (e.g. 4 animals per sex and per group in dog studies), at interim sampling times and at termination as described for rodents. Measurements at 3 months, either in rodents or non-rodents, need not be conducted if no effect was seen on clinical biochemistry parameters in a previous 90 day study carried out at comparable dose levels. Overnight fasting of the animals (with the exception of mice) prior to blood sampling is recommended. The following list of parameters should be investigated (30): glucose, urea (urea nitrogen), creatinine, total protein, albumin, calcium, sodium, potassium, total cholesterol, at least two appropriate tests for hepatocellular evaluation (alanine aminotransferase, aspartate aminotransferase, glutamate dehydrogenase, total bile acids) (31), and at least two appropriate tests for hepatobiliary evaluation (alkaline phosphatase, gamma glutamyl transferase, 5'-nucleotidase, total bilirubin, total bile acids) (31). Other clinical chemistry parameters such as fasting triglycerides, specific hormones and cholinesterase may be measured as appropriate, depending on the toxicity of the test chemical. Overall, there is a need for a flexible approach, depending on the observed and/or expected effect from a given test chemical.
43. Urinalysis determinations should be performed on at least 10 male and 10 female animals per group on samples collected at the same intervals as for haematology and clinical chemistry. Measurements at 3 months need not be conducted if no effect was seen on urinalysis in a previous 90 day study carried out at comparable dose levels. The following list of parameters was included in an expert recommendation on clinical pathology studies (30): appearance, volume, osmolality or specific gravity, pH, total protein, and glucose. Other determinations include ketone, urobilinogen, bilirubin, and occult blood. Further parameters may be employed where necessary to extend the investigation of observed effect(s).
44. It is generally considered that baseline haematological and clinical biochemistry variables are needed before treatment for dog studies, but need not be determined in rodent studies (30). However, if historical baseline data (see paragraph 50) are inadequate, consideration should be given to generating such data.

### Pathology

#### *Gross necropsy*

45. All animals in the study shall normally be subjected to a full, detailed gross necropsy which includes careful examination of the external surface of the body, all orifices, and the cranial, thoracic and abdominal cavities and their contents. However provision may also be made (in the interim kill or satellite groups) for measurements to be restricted to specific, key measures such as neurotoxicity or immunotoxicity (see paragraph 19). These animals need not be subjected to necropsy and the subsequent procedures described in the following paragraphs. Sentinel animals may require necropsy on a case-by-case basis, at the discretion of the study director.
46. Organ weights should be collected from all animals, other than those excluded by the latter part of paragraph 45. The adrenals, brain, epididymides, heart, kidneys, liver, ovaries, spleen, testes, thyroid (weighed post-fixation, with parathyroids), and uterus of all animals (apart from those found moribund and/or intercurrently killed) should be trimmed of any adherent tissue, as appropriate, and their wet weight taken as soon as possible after dissection to prevent drying. In a study using mice, weighing of the adrenal glands is optional.
47. The following tissues should be preserved in the most appropriate fixation medium for both the type of tissue and the intended subsequent histopathological examination (32) (tissues in square brackets are optional):

all gross lesions	heart	pancreas	stomach (forestomach, glandular stomach)
adrenal gland	ileum	parathyroid gland	[teeth]
aorta	jejunum	peripheral nerve	testis
brain (including sections of cerebrum, cerebellum, and medulla/pons)	kidney	pituitary	thymus
caecum	lacrimal gland (exorbital)	prostate	thyroid
cervix	liver	rectum	[tongue]

coagulating gland	lung	salivary gland	trachea
colon	lymph nodes (both superficial and deep)	seminal vesicle	urinary bladder
duodenum	mammary gland (obligatory for females and, if visibly dissectable, from males)	skeletal muscle	uterus (including cervix)
epididymis	[upper respiratory tract, including nose, turbinates, and paranasal sinuses]	skin	[ureter]
eye (including retina)	oesophagus	spinal cord (at three levels: cervical, mid-thoracic, and lumbar)	[urethra]
[femur with joint]	[olfactory bulb]	spleen	vagina
gall bladder (for species other than rat)	ovary	[sternum],	section of bone marrow and/or a fresh bone marrow aspirate
Harderian gland			

In the case of paired organs, e.g. kidney, adrenal, both organs should be preserved. The clinical and other findings may suggest the need to examine additional tissues. Also any organs considered likely to be target organs based on the known properties of the test chemical should be preserved. In studies involving the dermal route of administration, the list of organs as set out for the oral route should be preserved, and specific sampling and preservation of the skin from the site of application is essential. In inhalation studies, the list of preserved and examined tissues from the respiratory tract should follow the recommendations of Chapters B.8 of this Annex (8) and Chapter B.29 of this Annex (9). For other organs/tissues (and in addition to the specifically preserved tissues from the respiratory tract) the list of organs as set out for the oral route should be examined.

#### *Histopathology*

48. Guidance is available on best practices in the conduct of toxicological pathology studies (32). The minimum histopathological examinations should be:
- all tissues from the high dose and control groups;
  - all tissues from animals dying or killed during the study;
  - all tissues showing macroscopic abnormalities;
  - target tissues, or tissues which showed treatment-related changes in the high dose group, from all animals in all other dose groups;
  - in the case of paired organs, e.g. kidney, adrenal, both organs should be examined.

#### DATA AND REPORTING

##### **Data**

49. Individual animal data should be provided for all parameters evaluated. Additionally, all data should be summarised in tabular form showing for each test group the number of animals at the start of the test, the number of animals found dead during the test or killed for humane reasons and the time of any death or humane kill, the number showing signs of toxicity, a description of the signs of toxicity observed, including time of onset, duration, and severity of any toxic effects, the number of animals showing lesions, the type of lesions and the percentage of animals displaying each type of lesion. Summary data tables should provide the means and standard deviations (for continuous test data) of animals showing toxic effects or lesions, in addition to the grading of lesions.



50. Historical control data may be valuable in the interpretation of the results of the study, e.g. in the case when there are indications that the data provided by the concurrent controls are substantially out of line when compared to recent data from control animals from the same test facility/colony. Historical control data, if evaluated, should be submitted from the same laboratory and relate to animals of the same age and strain generated during the five years preceding the study in question.
51. When applicable, numerical results should be evaluated by an appropriate and generally acceptable statistical method. The statistical methods and the data to be analysed should be selected during the design of the study (paragraph 8). Selection should make provision for survival adjustments, if needed.

#### **Test Report**

52. The test report should include the following information:

##### *Test chemical:*

- physical nature, purity, and physicochemical properties;
- identification data;
- source of chemical;
- batch number;
- certificate of chemical analysis

##### *Vehicle (if appropriate):*

- justification for choice of vehicle (if other than water).

##### *Test animals:*

- species/strain used and justification for choice made;
- number, age, and sex of animals at start of test;
- source, housing conditions, diet, etc.;
- individual weights of animals at the start of the test.

##### *Test conditions:*

- rationale for route of administration and dose selection;
- when applicable, the statistical methods used to analyse the data;
- details of test chemical formulation/diet preparation;
- analytical data on achieved concentration, stability and homogeneity of the preparation;
- route of administration and details of the administration of the test chemical;
- for inhalation studies, whether nose only or whole body;
- actual doses (mg/kg body weight/day), and conversion factor from diet/drinking water test chemical concentration (mg/kg or ppm) to the actual dose, if applicable;
- details of food and water quality.

*Results (summary tabulated data and individual animal data should be presented):*

- survival data;
- body weight/body weight changes;
- food consumption, calculations of food efficiency, if made, and water consumption if applicable;
- toxic response data by sex and dose level, including signs of toxicity;
- nature, incidence (and, if scored, severity), and duration of clinical observations ((whether transitory or permanent);
- ophthalmological examination;
- haematological tests;
- clinical biochemistry tests;
- urinalysis tests;
- outcome of any investigations of neurotoxicity or immunotoxicity;
- terminal body weight;
- organ weights (and their ratios, if applicable);
- necropsy findings;
- a detailed description of all treatment-related histopathological findings;
- absorption data if available;

*Statistical treatment of results, as appropriate*

*Discussion of results including:*

- Dose: response relationships
- Consideration of any mode of action information
- Discussion of any modelling approaches
- BMD, NOAEL or LOAEL determination
- Historical control data
- Relevance for humans

*Conclusions*

**LITERATURE:**

- (1) OECD (1995). Report of the Consultation Meeting on Sub-chronic and Chronic Toxicity/Carcinogenicity Testing (Rome, 1995), internal working document, Environment Directorate, OECD, Paris.
- (2) Combes RD, Gaunt I, Balls M (2004). A Scientific and Animal Welfare Assessment of the OECD Health Effects Test Guidelines for the Safety Testing of Chemicals under the European Union REACH System. ATLA 32: 163-208.



- (3) Barlow SM, Greig JB, Bridges JW *et al.* (2002). Hazard identification by methods of animal-based toxicology. *Food. Chem. Toxicol.* 40, 145-191.
- (4) Chhabra RS, Bucher JR, Wolfe M, Portier C (2003). Toxicity characterization of environmental chemicals by the US National Toxicology Programme: an overview. *Int. J. Hyg. Environ. Health* 206: 437-445.
- (5) Chapter B.27 of this Annex, Sub-chronic Oral Toxicity Test Repeated Dose 90-day Oral Toxicity Study in Non-Rodents.
- (6) OECD (2012). Guidance Document on the Design and Conduct of Chronic Toxicity and Carcinogenicity Studies, Supporting Test Guidelines 451, 452 and 453 — Second edition. Series on Testing and Assessment No 116, available on the OECD public website for Test Guideline at [www.oecd.org/env/testguidelines](http://www.oecd.org/env/testguidelines).
- (7) OECD (2009). Guidance Document on Acute Inhalation Toxicity Testing, Series on Testing and Assessment No 39, ENV/JM/MONO(2009)28, OECD, Paris.
- (8) Chapter B.8 of this Annex, Subacute Inhalation Toxicity: 28-Day Study.
- (9) Chapter B.29 of this Annex, Subchronic Inhalation Toxicity: 90-Day Study.
- (10) Chapter B.9 of this Annex, Repeated Dose (28 Days) Toxicity (Dermal).
- (11) Carmichael NG, Barton HA, Boobis AR *et al.* (2006). Agricultural Chemical Safety Assessment: A Multisector Approach to the Modernization of Human Safety Requirements. *Critical Reviews in Toxicology* 36: 1-7.
- (12) Barton HA, Pastoor TP, Baetcke T *et al.* (2006). The Acquisition and Application of Absorption, Distribution, Metabolism, and Excretion (ADME) Data in Agricultural Chemical Safety Assessments. *Critical Reviews in Toxicology* 36: 9-35.
- (13) Doe JE, Boobis AR, Blacker A *et al.* (2006). A Tiered Approach to Systemic Toxicity Testing for Agricultural Chemical Safety Assessment. *Critical Reviews in Toxicology* 36: 37-68.
- (14) Cooper RL, Lamb JS, Barlow SM *et al.* (2006). A Tiered Approach to Life Stages Testing for Agricultural Chemical Safety Assessment. *Critical Reviews in Toxicology* 36: 69-98.
- (15) OECD (2002). Guidance Notes for Analysis and Evaluation of Chronic Toxicity and Carcinogenicity Studies, Series on Testing and Assessment No 35 and Series on Pesticides No 14, ENV/JM/MONO(2002)19, OECD, Paris.
- (16) OECD (2000). Guidance Document on the recognition, assessment, and use of clinical signs as humane endpoints for experimental animals used in safety evaluation, No 19, ENV/JM/MONO(2000)7, OECD, Paris.
- (17) Rhomberg LR, Baetcke K, Blancato J, Bus J, Cohen S, Conolly R, Dixit R, Doe J, Ekelman K, Fenner-Crisp P, Harvey P, Hattis D, Jacobs A, Jacobson-Kram D, Lewandowski T, Liteplo R, Pelkonen O, Rice J, Somers D, Turturro A, West W, Olin S (2007). Issues in the Design and Interpretation of Chronic Toxicity and Carcinogenicity Studies in Rodents: Approaches to Dose Selection *Crit Rev. Toxicol.* 37 (9): 729 - 837.
- (18) ILSI (International Life Sciences Institute) (1997). Principles for the Selection of Doses in Chronic Rodent Bioassays. Foran JA (Ed.). ILSI Press, Washington, DC.
- (19) Directive 2010/63/EU of the European parliament and of the Council of 22 September 2010 on the protection of animals used for scientific purposes (OJ L 276, 20.10.2010, p. 33).
- (20) National Research Council, 1985. Guide for the care and use of laboratory animals. NIH Publication No 86-23. Washington D.C., US. Dept. of Health and Human Services.
- (21) GV-SOLAS (Society for Laboratory Animal Science, Gesellschaft für Versuchstierkunde, 1988). Publication on the Planning and Structure of Animal Facilities for Institutes Performing Animal Experiments. ISBN 3-906255-04-2.

- 
- (22) GV-SOLAS (Society for Laboratory Animal Science, Gesellschaft für Versuchstierkunde, 2006). Microbiological monitoring of laboratory animals in various housing systems.
  - (23) Diehl K-H, Hull R, Morton D, Pfister R, Rabemampianina Y, Smith D, Vidal J-M, van de Vorstenbosch C. 2001. A good practice guide to the administration of substances and removal of blood, including routes and volumes. *Journal of Applied Toxicology* 21:15-23.
  - (24) IPCS (1986). Principles and Methods for the Assessment of Neurotoxicity Associated with Exposure to Chemicals. Environmental Health Criteria Document No 60.
  - (25) Tupper DE, Wallace RB (1980). Utility of the Neurologic Examination in Rats. *Acta Neurobiol. Exp.* 40: 999-1003.
  - (26) Gad SC (1982). A Neuromuscular Screen for Use in Industrial Toxicology. *J. Toxicol. Environ. Health* 9: 691-704.
  - (27) Moser VC, McDaniel KM, Phillips PM (1991). Rat Strain and Stock Comparisons Using a Functional Observational Battery: Baseline Values and Effects of Amitraz. *Toxicol. Appl. Pharmacol.* 108: 267-283.
  - (28) Meyer OA, Tilson HA, Byrd WC, Riley MT (1979). A Method for the Routine Assessment of Fore- and Hind-limb Grip Strength of Rats and Mice. *Neurobehav. Toxicol.* 1: 233-236.
  - (29) Crofton KM, Howard JL, Moser VC, Gill MW, Reiter LW, Tilson HA, MacPhail RC (1991). Interlaboratory Comparison of Motor Activity Experiments: Implication for Neurotoxicological Assessments. *Neurotoxicol. Teratol.* 13: 599-609.
  - (30) Weingand K, Brown G, Hall R *et al.* (1996). Harmonisation of Animal Clinical Pathology Testing in Toxicity and Safety Studies. *Fundam. & Appl. Toxicol.* 29: 198-201.
  - (31) EMEA (draft) document "Non-clinical guideline on drug-induced hepatotoxicity" (Doc. Ref. EMEA/CHMP/SWP/a50115/2006).
  - (32) Crissman JW, Goodman DG, Hildebrandt PK *et al.* (2004). Best Practices Guideline: Toxicological Histopathology. *Toxicologic Pathology* 32: 126-131.
-

## Appendix 1

## DEFINITION

**Test chemical:** Any substance or mixture tested using this Test Method.'

(6) Chapters B.32 and B.33 are replaced by the following:

**B.32. CARCINOGENICITY STUDIES**

## INTRODUCTION

1. This Test Method is equivalent to OECD Test Guideline (TG) 451 (2009). The original TG 451 on Carcinogenicity Studies was adopted in 1981. Development of this revised Test Method B.32 was considered necessary, in order to reflect recent developments in the field of animal welfare and regulatory requirements (2) (3) (4) (5) (6). The updating of this Test Method B.32 has been carried out in parallel with revisions of Chapter B.30 of this Annex, Chronic Toxicity Studies, and Chapter B.33, of this Annex, Combined Chronic Toxicity\Carcinogenicity Studies, and with the objective of obtaining additional information from the animals used in the study and providing further detail on dose selection. This Test Method B.32 is designed to be used in the testing of a broad range of chemicals, including pesticides and industrial chemicals. It should be noted however that some details and requirements may differ for pharmaceuticals (see International Conference on Harmonisation (ICH) Guidance S1B on Testing for Carcinogenicity of Pharmaceuticals).
2. The majority of carcinogenicity studies are carried out in rodent species, and this Test Method is intended therefore to apply primarily to studies carried out in these species. Should such studies be required in non-rodent species, the principles and procedures outlined in this Test Method together with those outlined in Chapter B.27 of this Annex, Repeated Dose 90-day Oral Toxicity Study in Non-Rodents (6), should be applied, with appropriate modifications. Further guidance is available in the OECD Guidance Document No 116 on the Design and Conduct of Chronic Toxicity and Carcinogenicity Studies (7).
3. The three main routes of administration used in carcinogenicity studies are oral, dermal and inhalation. The choice of the route of administration depends on the physical and chemical characteristics of the test chemical and the predominant route of exposure of humans. Additional information on choice of route of exposure is provided in Guidance Document No 116 (7).
4. This Test Method focuses on exposure via the oral route, the route most commonly used in carcinogenicity studies. While carcinogenicity studies involving exposure via the dermal or inhalation routes may also be necessary for human health risk assessment and/or may be required under certain regulatory regimes, both routes of exposure involve considerable technical complexity. Such studies will need to be designed on a case-by-case basis, although the Test Method outlined here for the assessment and evaluation of carcinogenicity by oral administration could form the basis of a protocol for inhalation and/or dermal studies, with respect to recommendations for treatment periods, clinical and pathology parameters, etc. OECD Guidance is available on the administration of test chemicals by the dermal (7), and inhalation routes (7) (8). Chapter B.8 of this Annex (9) and Chapter B.29 of this Annex (10), together with the OECD Guidance Document on acute inhalation testing (8), should be specifically consulted in the design of longer term studies involving exposure via the inhalation route. Chapter B.9 of this Annex (11) should be consulted in the case of testing carried out by the dermal route.
5. The carcinogenicity study provides information on the possible health hazards likely to arise from repeated exposure for a period lasting up to the entire lifespan of the species used. The study will provide information on the toxic effects of the test chemical including potential carcinogenicity, and may indicate target organs and the possibility of accumulation. It can provide an estimate of the no-observed-adverse effect level for toxic effects and, in the case of non-genotoxic carcinogens, for tumour responses, which can be used for establishing safety criteria for human exposure. The need for careful clinical observations of the animals, so as to obtain as much information as possible, is also stressed.
6. The objectives of carcinogenicity studies covered by this Test Method include:
  - The identification of the carcinogenic properties of a test chemical, resulting in an increased incidence of neoplasms, increased proportion of malignant neoplasms or a reduction in the time to appearance of neoplasms, compared with concurrent control groups;
  - The identification of target organ(s) of carcinogenicity;
  - The identification of the time to appearance of neoplasms;

- Characterisation of the tumour dose-response relationship;
- Identification of a no-observed-adverse-effect level (NOAEL) or point of departure for establishment of a Benchmark Dose (BMD);
- Extrapolation of carcinogenic effects to low dose human exposure levels;
- Provision of data to test hypotheses regarding mode of action (2) (7) (12) (13) (14) (15).

#### INITIAL CONSIDERATIONS

7. In the assessment and evaluation of the potential carcinogenicity of a test chemical, all available information on the test chemical should be considered by the testing laboratory prior to conducting the study, in order to focus the design of the study to more efficiently test for carcinogenic potential and to minimise animal usage. Information on, and consideration of, the mode of action of a suspected carcinogen (2) (7) (12) (13) (14) (15) is particularly important, since the optimal design may differ depending on whether the test chemical is a known or suspected genotoxic carcinogen. Further guidance on mode of action considerations can be found in Guidance Document No 116 (7).
8. Information that will assist in the study design includes the identity, chemical structure, and physico-chemical properties of the test chemical; results of any *in vitro* or *in vivo* toxicity tests including genotoxicity tests; anticipated use(s) and potential for human exposure; available (Q)SAR data, mutagenicity/genotoxicity, carcinogenicity and other toxicological data on structurally-related chemicals; available toxicokinetic data (single dose and also repeat dose kinetics where available) and data derived from other repeated exposure studies. Assessment of carcinogenicity should be carried out after initial information on toxicity has been obtained from repeated dose 28-day and/or 90-day toxicity tests. Short-term cancer initiation-promotion tests could also provide useful information. A phased testing approach to carcinogenicity testing should be considered as part of the overall assessment of the potential adverse health effects of a particular test chemical (16) (17) (18) (19).
9. The statistical methods most appropriate for the analysis of results, given the experimental design and objectives, should be established before commencing the study. Issues to consider include whether the statistics should include adjustment for survival, analysis of cumulative tumour risks relative to survival duration, analysis of the time to tumour and analysis in the event of premature termination of one or more groups. Guidance on the appropriate statistical analyses and key references to internationally accepted statistical methods are given in Guidance Document No 116 (7), and also in Guidance Document No 35 on the analysis and evaluation of chronic toxicity and carcinogenicity studies (20).
10. In conducting a carcinogenicity study, the guiding principles and considerations outlined in the OECD Guidance Document No 19 on the recognition, assessment, and use of clinical signs as humane endpoints for experimental animals used in safety evaluation (21), in particular paragraph 62 thereof, should always be followed. This paragraph states that *"In studies involving repeated dosing, when an animal shows clinical signs that are progressive, leading to further deterioration in condition, an informed decision as to whether or not to humanely kill the animal should be made. The decision should include consideration as to the value of the information to be gained from the continued maintenance of that animal on study relative to its overall condition. If a decision is made to leave the animal on test, the frequency of observations should be increased, as needed. It may also be possible, without adversely affecting the purpose of the test, to temporarily stop dosing if it will relieve the pain or distress, or reduce the test dose."*
11. Detailed guidance on and discussion of the principles of dose selection for chronic toxicity and carcinogenicity studies can be found in Guidance Document No 116 (7) as well as two International Life Sciences Institute publications (22) (23). The core dose selection strategy is dependent on the primary objective or objectives of the study (paragraph 6). In selecting appropriate dose levels, a balance should be achieved between hazard screening on the one hand and characterisation of low-dose responses and their relevance on the other. This is particularly relevant in the situation where a combined chronic toxicity and carcinogenicity study (Chapter B.33 of this Annex) is to be carried out (paragraph 12).
12. Consideration should be given to carrying out a combined chronic toxicity and carcinogenicity study (Chapter B.33 of this Annex), rather than separate execution of a chronic toxicity study (Chapter B.30 of this Annex) and carcinogenicity study (this Test Method B.32). The combined test provides greater efficiency in terms of time and cost compared to conducting two separate studies, without compromising the quality of the data in either the chronic phase or the carcinogenicity phase. Careful consideration should however be given to the principles of dose selection (paragraphs 11 and 22-25) when undertaking a combined chronic toxicity and carcinogenicity study (Chapter B.33 of this Annex), and it is also recognised that separate studies may be required under certain regulatory frameworks.

13. Definitions used in the context of this Test Method can be found at the end of this chapter and in the Guidance Document No 116 (7).

#### PRINCIPLE OF THE TEST

14. The test chemical is administered daily in graduated doses to several groups of test animals for the majority of their life span, normally by the oral route. Testing by the inhalation or dermal route may also be appropriate. The animals are observed closely for signs of toxicity and for the development of neoplastic lesions. Animals which die or are killed during the test are necropsied and, at the conclusion of the test, surviving animals are killed and necropsied.

#### DESCRIPTION OF METHOD

##### **Selection of animal species**

15. This Test Method primarily covers assessment and evaluation of carcinogenicity in rodents (paragraph 2). The use of non-rodent species may be considered when available data suggest that they are more relevant for the prediction of health effects in humans. The choice of species should be justified. The preferred rodent species is the rat, although other rodent species, e.g. the mouse, may be used. Although the use of the mouse in carcinogenicity testing may have limited utility (24) (25) (26), under some current regulatory programmes carcinogenicity testing in the mouse is still required unless it is determined that such a study is not scientifically necessary. Rats and mice have been preferred experimental models because of their relatively short life span, their widespread use in pharmacological and toxicological studies, their susceptibility to tumour induction, and the availability of sufficiently characterised strains. As a consequence of these characteristics, a large amount of information is available on their physiology and pathology. Additional information on choice of species and strain is provided in Guidance Document No 116 (7).
16. Young healthy adult animals of commonly used laboratory strains should be employed. The carcinogenicity study should preferably be carried out in animals from the same strain and source as those used in preliminary toxicity study(ies) of shorter duration although, if animals from this strain and source are known to present problems in achieving the normally accepted criteria of survival for long-term studies [see Guidance Document No 116 (7)], consideration should be given to using a strain of animal that has an acceptable survival rate for the long-term study. The females should be nulliparous and non-pregnant.

##### **Housing and feeding**

17. Animals may be housed individually, or be caged in small groups of the same sex; individual housing should be considered only if scientifically justified (27) (28) (29). Cages should be arranged in such a way that possible effects due to cage placement are minimised. The temperature in the experimental animal room should be 22 °C ( $\pm$  3 °C). Although the relative humidity should be at least 30 % and preferably not exceed 70 % other than during room cleaning, the aim should be 50-60 %. Lighting should be artificial, the sequence being 12 hours light, 12 hours dark. For feeding, conventional laboratory diets may be used with an unlimited supply of drinking water. The diet should meet all the nutritional requirements of the species tested and the content of dietary contaminants, including but not limited to pesticide residues, persistent organic pollutants, phytoestrogens, heavy metals and mycotoxins, that might influence the outcome of the test, should be as low as possible. Analytical information on the nutrient and dietary contaminant levels should be generated periodically, at least at the beginning of the study and when there is a change in the batch used, and should be included in the final report. Analytical information on the drinking water used in the study should similarly be provided. The choice of diet may be influenced by the need to ensure a suitable admixture of a test chemical and to meet the nutritional requirements of the animals when the test chemical is administered by the dietary route.

##### **Preparation of animals**

18. Healthy animals, which have been acclimated to laboratory conditions for at least 7 days and have not been subjected to previous experimental procedures, should be used. In the case of rodents, dosing of the animals should begin as soon as possible after weaning and acclimatisation and preferably before the animals are 8 weeks old. The test animals should be characterised as to species, strain, source, sex, weight and age. At the commencement of the study, the weight variation for each sex of animal used should be minimal and not exceed  $\pm$  20 % of the mean weight of all the animals within the study, separately for each sex. Animals should be randomly assigned to the control and treatment groups. After randomisation, there should be no significant differences in mean body weights between groups within each sex. If there are statistically significant differences, then the randomisation step should be repeated, if possible. Each animal should be assigned a unique identification number, and permanently marked with this number by tattooing, microchip implant, or other suitable method.

## PROCEDURE

**Number and sex of animals**

19. Both sexes should be used. A sufficient number of animals should be used so that a thorough biological and statistical evaluation is possible. Each dose group and concurrent control group should therefore contain at least 50 animals of each sex. Depending on the aim of the study, it may be possible to increase the statistical power of the key estimates by differentially allocating animals unequally to the various dose groups, with more than 50 animals in the low dose groups; e.g. to estimate the carcinogenic potential at low doses. However it should be recognised that a moderate increase in group size will provide relatively little increase in statistical power of the study. Further information on statistical design of the study and choice of dose levels to maximise statistical power is provided in Guidance Document No 116 (7).

**Provision for interim kills and satellite (sentinel) groups**

20. The study may make provision for interim kills, e.g. at 12 months, to provide information on progression of neoplastic changes and mechanistic information, if scientifically justified. Where such information is already available from previous repeat dose toxicity studies on the test chemical, interim kills may not be scientifically justified. If interim kills are included in the study design, the number of animals in each dose group scheduled for an interim kill will normally be 10 animals per sex, and the total number of animals included in the study design should be increased by the number of animals scheduled to be killed before the completion of the study. An additional group of sentinel animals (typically 5 animals per sex) may be included for monitoring of disease status, if necessary, during the study (30). Further guidance is provided in Guidance Document No 116 (7).

**Dose groups and dosage**

21. Guidance on all aspects of dose selection and dose level spacing is provided in Guidance Document No 116 (7). At least three dose levels and a concurrent control should be used. Dose levels will generally be based on the results of shorter-term repeated dose or range finding studies and should take into account any existing toxicological and toxicokinetic data available for the test chemical or related chemicals.
22. Unless limited by the physical-chemical nature or biological effects of the test chemical, the highest dose level should be chosen to identify the principal target organs and toxic effects while avoiding suffering, severe toxicity, morbidity, or death. While taking into account the factors outlined in paragraph 23 below, the highest dose level should normally be chosen to elicit evidence of toxicity, as evidenced by, for example, depression of body weight gain (approximately 10 %). However, dependent on the objectives of the study (see paragraph 6), a top dose lower than the dose providing evidence of toxicity may be chosen, e.g. if a dose elicits an adverse effect of concern that nonetheless has little impact on lifespan or body weight.
23. Dose levels and dose level spacing may be selected to establish a dose-response and, depending on the mode of action of the test chemical, a NOAEL or other intended outcome of the study, e.g. a BMD (see paragraph 25) at the lowest dose level. Factors that should be considered in the placement of lower doses include the expected slope of the dose-response curve, the doses at which important changes may occur in metabolism or mode of toxic action, where a threshold is expected, or where a point of departure for low-dose extrapolation is expected.
24. The dose level spacing selected will depend on the characteristics of the test chemical, and cannot be prescribed in this Test Method, but two to four fold intervals frequently provide good test performance for setting the descending dose levels and addition of a fourth test group is often preferable to using very large intervals (e.g. more than a factor of about 6-10) between dosages. In general, the use of factors greater than 10 should be avoided, and should be justified if used.
25. As discussed further in Guidance Document No 116 (7), points to be considered in dose selection include:
  - Known or suspected nonlinearities or inflection points in the dose-response;
  - Toxicokinetics, and dose ranges where metabolic induction, saturation, or nonlinearity between external and internal doses does or does not occur;
  - Precursor lesions, markers of effect, or indicators of the operation of key underlying biological processes;
  - Key (or suspected) aspects of mode of action, such as doses at which cytotoxicity begins to arise, hormone levels are perturbed, homeostatic mechanisms are overwhelmed, etc.;



- Regions of the dose–response curve where particularly robust estimation is needed, e.g. in the range of the anticipated BMD or a suspected threshold;
  - Consideration of anticipated human exposure levels.
26. The control group shall be an untreated group or a vehicle-control group if a vehicle is used in administering the test chemical. Except for treatment with the test chemical, animals in the control group should be handled in an identical manner to those in the test groups. If a vehicle is used, the control group shall receive the vehicle in the highest volume used among the dose groups. If a test chemical is administered in the diet, and causes significantly reduced dietary intake due to the reduced palatability of the diet, an additional pair-fed control group may be useful, to serve as a more suitable control.

#### **Preparation of doses and administration of test chemical**

27. The test chemical is normally administered orally, via the diet or drinking water, or by gavage. Additional information on routes and methods of administration is provided in Guidance Document No 116 (7). The route and method of administration is dependent on the purpose of the study, the physical-chemical properties of the test chemical, its bioavailability and the predominant route and method of exposure of humans. A rationale should be provided for the chosen route and method of administration. In the interest of animal welfare, oral gavage should normally be selected only for those agents, for which this route and method of administration reasonably represent potential human exposure (e.g. pharmaceuticals). For dietary or environmental chemicals including pesticides, administration is typically via the diet or drinking water. However, for some scenarios, e.g. occupational exposure, administration via other routes may be more appropriate.
28. Where necessary, the test chemical is dissolved or suspended in a suitable vehicle. Consideration should be given to the following characteristics of the vehicle and other additives, as appropriate: effects on the absorption, distribution, metabolism, or retention of the test chemical; effects on the chemical properties of the test chemical which may alter its toxic characteristics; and effects on the food or water consumption or the nutritional status of the animals. It is recommended that, wherever possible, the use of an aqueous solution/suspension be considered first, followed by consideration of a solution/emulsion in oil (e.g. corn oil) and then by possible solution in other vehicles. For vehicles other than water, the toxic characteristics of the vehicle should be known. Information should be available on the stability of the test chemical and the homogeneity of dosing solutions or diets (as appropriate) under the conditions of administration (e.g. diet).
29. For chemicals administered via the diet or drinking water it is important to ensure that the quantities of the test chemical involved do not interfere with normal nutrition or water balance. In long-term toxicity studies using dietary administration, the concentration of the test chemical in the feed should not normally exceed an upper limit of 5 % of the total diet, in order to avoid nutritional imbalances. When the test chemical is administered in the diet, either a constant dietary concentration (mg/kg diet or ppm) or a constant dose level in terms of the animal's body weight (mg/kg body weight), calculated on a weekly basis, may be used. The alternative used should be specified.
30. In the case of oral administration, the animals are dosed with the test chemical daily (seven days per week), normally for a period of 24 months for rodents (see also paragraph 32). Any other dosing regime, e.g. five days per week, needs to be justified. In the case of dermal administration, animals are normally treated with the test chemical for at least 6 hours per day, 7 days per week, as specified in Chapter B.9 of this Annex (11), for a period of 24 months. Exposure by the inhalation route is carried out for 6 hours per day, 7 days per week, but exposure for 5 days per week may also be used, if justified. The period of exposure will normally be for a period of 24 months. If rodent species other than rats are exposed nose-only, maximum exposure durations may be adjusted to minimise species-specific distress. A rationale should be provided when using an exposure duration of less than 6 hours per day. See also Chapter B.8 of this Annex (9).
31. When the test chemical is administered by gavage to the animals, this should be done using a stomach tube or a suitable intubation cannula, at similar times each day. Normally a single dose will be administered once daily; where for example a chemical is a local irritant, it may be possible to maintain the daily dose-rate by administering it as a split dose (twice a day). The maximum volume of liquid that can be administered at one time depends on the size of the test animal. The volume should be kept as low as practical, and should not normally exceed 1 ml/100g body weight for rodents (31). Variability in test volume should be minimised by adjusting the concentration to ensure a constant volume at all dose levels. Potentially corrosive or irritant chemicals are the exception, and need to be diluted to avoid severe local effects. Testing at concentrations that are likely to be corrosive or irritant to the gastrointestinal tract should be avoided.

### Duration of study

32. The duration of the study will normally be 24 months for rodents, representing the majority of the normal life span of the animals to be used. Shorter or longer study durations may be used, dependent on the lifespan of the strain of the animal species in the study, but should be justified. For specific strains of mice, e.g. AKR/J, C3H/J or C57BL/6J strains a duration of 18 months may be more appropriate. The following provides some guidance on duration, termination of the study and survival; further guidance, including consideration of the acceptability of a negative carcinogenicity relative to survival in the study, is provided in the OECD Guidance Document No 116 on the Design and Conduct of Chronic Toxicity and Carcinogenicity Studies (7).
- Termination of the study should be considered when the number of survivors in the lower dose groups or the control group falls below 25 per cent.
  - In the case where only the high dose group dies prematurely due to toxicity, this should not trigger termination of the study.
  - Survival of each sex should be considered separately.
  - The study should not be extended beyond the point when the data available from the study are no longer sufficient to enable a statistically valid evaluation to be made.

### OBSERVATIONS

33. All animals should be checked for morbidity or mortality, usually at the beginning and the end of each day, including at weekends and holidays. Animals should additionally be checked once a day for specific signs of toxicological relevance, taking into consideration the peak period of anticipated effects after dosing in the case of gavage administration. Particular attention should be paid to tumour development; and the time of tumour onset, location, dimensions, appearance, and progression of each grossly visible or palpable tumour should be recorded.

#### *Body weight, food/water consumption and food efficiency*

34. All animals should be weighed at the start of treatment, at least once a week for the first 13 weeks and at least monthly thereafter. Measurements of food consumption and food efficiency should be made at least weekly for the first 13 weeks and at least monthly thereafter. Water consumption should be measured at least weekly for the first 13 weeks and at least monthly thereafter when the test chemical is administered in drinking water. Water consumption measurements should also be considered for studies in which drinking activity is altered.

#### *Haematology, clinical biochemistry and other measurements*

35. In order to maximise the information obtained from the study, especially for mode of action considerations, blood samples may be taken for haematology and clinical biochemistry, and this at the discretion of the study director. Urinalysis may also be appropriate. Further guidance on the value of taking such samples as part of a carcinogenicity study is provided in Guidance Document No 116 (7). If considered appropriate, blood sampling for haematological and clinical chemistry determinations and urinalysis may be conducted as part of an interim kill (paragraph 20) and at study termination on a minimum of 10 animals per sex per group. Blood samples should be taken from a named site, for example by cardiac puncture or from the retro-orbital sinus under anaesthesia, and stored, if applicable, under appropriate conditions. Blood smears may also be prepared for examination, particularly if bone marrow appears to be the target organ, although the value of such examination for the assessment of carcinogenic/oncogenic potential has been questioned (32).

### PATHOLOGY

#### *Gross necropsy*

36. All animals in the study except sentinel animals (see paragraph 20) and other satellite animals should be subjected to a full, detailed gross necropsy which includes careful examination of the external surface of the body, all orifices, and the cranial, thoracic and abdominal cavities and their contents. Sentinel animals and other satellite animals may require necropsy on a case-by-case basis, at the discretion of the study director. Organ weights are not normally part of a carcinogenesis study, since geriatric changes and, at later stages, the development of tumours confounds the usefulness of organ weight data. They may, however, be critical to performing a weight of evidence evaluation and especially for mode of action considerations. If they are part of a satellite study, they should be collected at no later than one year after initiation of the study.
37. The following tissues should be preserved in the most appropriate fixation medium for both the type of tissue and the intended subsequent histopathological examination (33) (tissues in square brackets are optional):



all gross lesions	heart	pancreas	stomach (forestomach, glandular stomach)
adrenal gland	ileum	parathyroid gland	[teeth]
aorta	jejunum	peripheral nerve	testis
brain (including sections of cerebrum, cerebellum, and medulla/pons)	kidney	pituitary	thymus
caecum	lacrimal gland (exorbital)	prostate	thyroid
cervix	liver	rectum	[tongue]
coagulating gland	lung	salivary gland	trachea
colon	lymph nodes (both superficial and deep)	seminal vesicle	urinary bladder
duodenum	mammary gland (obligatory for females and, if visibly dissectable, from males)	skeletal muscle	uterus (including cervix)
epididymis	[upper respiratory tract, including nose, turbinates, and paranasal sinuses]	skin	[ureter]
eye (including retina)	oesophagus	spinal cord (at three levels: cervical, mid-thoracic, and lumbar)	[urethra]
[femur with joint]	[olfactory bulb]	spleen	vagina
gall bladder (for species other than rat)	ovary	[sternum],	section of bone marrow and/or a fresh bone marrow aspirate
Harderian gland			

In the case of paired organs, e.g. kidney, adrenal, both organs should be preserved. The clinical and other findings may suggest the need to examine additional tissues. Also, any organs considered likely to be target organs based on the known properties of the test chemical should be preserved. In studies involving the dermal route of administration, the list of organs as set out for the oral route should be preserved, and specific sampling and preservation of the skin from the site of application is essential. In inhalation studies, the list of preserved and examined tissues from the respiratory tract should follow the recommendations of Chapters B.8 and B.29 of this Annex. For other organs/tissues (and in addition to the specifically preserved tissues from the respiratory tract) the list of organs as set out for the oral route should be examined.

#### *Histopathology*

38. Guidance is available on best practices in the conduct of toxicological pathology studies (33). The minimum tissues examined should be:

- All tissues from the high dose and control groups;
- All tissues of animals dying or killed during the study;
- All tissues showing macroscopic abnormalities including tumours;
- When treatment-related histopathological changes are observed in the high dose group, those same tissues are to be examined from all animals in all other dose groups;
- In the case of paired organs, e.g. kidney, adrenal, both organs should be examined.

## DATA AND REPORTING

**Data**

39. Individual animal data should be provided for all parameters evaluated. Additionally, all data should be summarised in tabular form showing for each test group the number of animals at the start of the test, the number of animals found dead during the test or killed for humane reasons and the time of any death or humane kill, the number showing signs of toxicity, a description of the signs of toxicity observed, including time of onset, duration, and severity of any toxic effects, the number of animals showing lesions, the type of lesions and the percentage of animals displaying each type of lesion. Summary data tables should provide the means and standard deviations (for continuous test data) of animals showing toxic effects or lesions, in addition to the grading of lesions.
40. Historical control data may be valuable in the interpretation of the results of the study, e.g. in the case when there are indications that the data provided by the concurrent controls are substantially out of line when compared to recent data from control animals from the same test facility/colony. Historical control data, if evaluated, should be submitted from the same laboratory and relate to animals of the same age and strain generated during the five years preceding the study in question.
41. When applicable, numerical results should be evaluated by an appropriate and generally acceptable statistical method. The statistical methods and the data to be analysed should be selected during the design of the study (paragraph 9). Selection should make provision for survival adjustments, if needed.

**Test report**

42. The test report should include the following information:

*Test chemical:*

- physical nature, purity, and physicochemical properties;
- identification data;
- source of chemical;
- batch number;
- certificate of chemical analysis;

*Vehicle (if appropriate):*

- justification for choice of vehicle (if other than water);

*Test animals:*

- species/strain used and justification for choice made;
- number, age, and sex of animals at start of test;
- source, housing conditions, diet, etc.;
- individual weights of animals at the start of the test;

*Test conditions:*

- rationale for route of administration and dose selection;
- when applicable, the statistical methods used to analyse the data;
- details of test chemical formulation/diet preparation.
- analytical data on achieved concentration, stability and homogeneity of the preparation;

- route of administration and details of the administration of the test chemical;
- for inhalation studies, whether nose only or whole body;
- actual doses (mg/kg body weight/day), and conversion factor from diet/drinking water test chemical concentration (mg/kg or ppm) to the actual dose, if applicable;
- details of food and water quality;

*Results (summary tabulated data and individual animal data should be presented)*

#### *General*

- survival data;
- body weight/body weight changes;
- food consumption, calculations of food efficiency, if made, and water consumption, if applicable;
- toxicokinetic data (if available);
- ophthalmoscopy (if available);
- haematology (if available);
- clinical chemistry (if available);

#### *Clinical findings*

- Signs of toxicity;
- Incidence (and, if scored, severity) of any abnormality;
- Nature, severity, and duration of clinical observations (whether transitory or permanent);

#### *Necropsy data*

- Terminal body weight;
- Organ weights and their ratios, if applicable;
- Necropsy findings; Incidence and severity of abnormalities;

#### *Histopathology*

- Non neoplastic histopathological findings;
- Neoplastic histopathological findings;
- Correlation between gross and microscopic findings;
- Detailed description of all treatment-related histopathological findings including severity gradings;

— Report of any peer review of slides;

*Statistical treatment of results, as appropriate*

*Discussion of results including*

— Discussion of any modelling approaches;

— Dose-response relationships;

— Historical control data;

— Consideration of any mode of action information;

— BMD, NOAEL or LOAEL determination;

— Relevance for humans;

*Conclusions*

**LITERATURE:**

- (1) OECD (1995). Report of the Consultation Meeting on Sub-chronic and Chronic Toxicity/Carcinogenicity Testing (Rome, 1995), internal working document, Environment Directorate, OECD, Paris.
- (2) EPA (2005). Guidelines for Carcinogen Risk Assessment Risk Assessment Forum U.S. Environmental Protection Agency Washington, DC.
- (3) Combes RD, Gaunt, I, Balls M (2004). A Scientific and Animal Welfare Assessment of the OECD Health Effects Test Guidelines for the Safety Testing of Chemicals under the European Union REACH System. ATLA 32: 163-208.
- (4) Barlow SM, Greig JB, Bridges JW et al (2002). Hazard identification by methods of animal-based toxicology. Food. Chem. Toxicol. 40: 145-191.
- (5) Chhabra RS, Bucher JR, Wolfe M, Portier C (2003). Toxicity characterization of environmental chemicals by the US National Toxicology Programme: an overview. Int. J. Hyg. Environ. Health 206: 437-445.
- (6) Chapter B.27 of this Annex, Sub-chronic Oral Toxicity Test Repeated Dose 90-day Oral Toxicity Study in Non-Rodents.
- (7) OECD (2012). Guidance Document on the Design and Conduct of Chronic Toxicity and Carcinogenicity Studies, Supporting Test Guidelines 451, 452 and 453 — Second edition. Series on Testing and Assessment No 116, available on the OECD public website for Test Guideline at [www.oecd.org/env/testguidelines](http://www.oecd.org/env/testguidelines).
- (8) OECD (2009). Guidance Document on Acute Inhalation Toxicity Testing, Series on Testing and Assessment No 39, ENV/JM/MONO(2009)28, OECD, Paris.
- (9) Chapter B.8 of this Annex, Subacute Inhalation Toxicity: 28-Day Study.
- (10) Chapter B.29 of this Annex, Subchronic Inhalation Toxicity: 90-Day Study.
- (11) Chapter B.9 of this Annex, Repeated Dose (28 Days) Toxicity (Dermal).
- (12) Boobis AR, Cohen SM, Dellarco V, McGregor D, Meek ME, Vickers C, Willcocks D, Farland W (2006). IPCS Framework for analyzing the Relevance of a Cancer Mode of Action for Humans. Crit. Rev. in Toxicol, 36: 793-801.
- (13) Cohen SM, Meek ME, Klaunig JE, Patton DE, and Fenner-Crisp PA (2003). The human relevance of information on carcinogenic Modes of Action: An Overview. Crit. Rev. Toxicol. 33: 581-589.

- (14) Holsapple MP, Pitot HC, Cohen SN, Boobis AR, Klaunig JE, Pastoor T, Dellarco VL, Dragan YP (2006). Mode of Action in Relevance of Rodent Liver Tumors to Human Cancer Risk. *Toxicol. Sci.* 89: 51-56.
- (15) Meek EM, Bucher JR, Cohen SM, Dellarco V, Hill RN, Lehman-McKemmon LD, Longfellow DG, Pastoor T, Seed J, Patton DE (2003). A Framework for Human Relevance analysis of Information on Carcinogenic Modes of Action. *Crit. Rev. Toxicol.* 33: 591-653.
- (16) Carmichael NG, Barton HA, Boobis AR et al (2006). Agricultural Chemical Safety Assessment: A Multisector Approach to the Modernization of Human Safety Requirements. *Critical Reviews in Toxicology* 36: 1-7.
- (17) Barton HA, Pastoor TP, Baetcke T et al (2006). The Acquisition and Application of Absorption, Distribution, Metabolism, and Excretion (ADME) Data in Agricultural Chemical Safety Assessments. *Critical Reviews in Toxicology* 36: 9-35.
- (18) Doe JE, Boobis AR, Blacker A et al (2006). A Tiered Approach to Systemic Toxicity Testing for Agricultural Chemical Safety Assessment. *Critical Reviews in Toxicology* 36: 37-68.
- (19) Cooper RL, Lamb JS, Barlow SM et al (2006). A Tiered Approach to Life Stages Testing for Agricultural Chemical Safety Assessment. *Critical Reviews in Toxicology* 36: 69-98.
- (20) OECD (2002). Guidance Notes for Analysis and Evaluation of Chronic Toxicity and Carcinogenicity Studies, Series on Testing and Assessment No 35 and Series on Pesticides No 14, ENV/JM/MONO(2002)19, OECD, Paris.
- (21) OECD (2000). Guidance Document on the recognition, assessment, and use of clinical signs as humane endpoints for experimental animals used in safety evaluation, Series on Testing and Assessment No 19, ENV/JM/MONO(2000)7, OECD, Paris.
- (22) Rhomberg LR, Baetcke K, Blancato J, Bus J, Cohen S, Conolly R, Dixit R, Doe J, Ekelman K, Fenner-Crisp P, Harvey P, Hattis D, Jacobs A, Jacobson-Kram D, Lewandowski T, Liteplo R, Pelkonen O, Rice J, Somers D, Turturro A, West, W, Olin S(2007). Issues in the Design and Interpretation of Chronic Toxicity and Carcinogenicity Studies in Rodents: Approaches to Dose Selection *Crit Rev. Toxicol.* 37 (9): 729 – 837.
- (23) ILSI (International Life Sciences Institute) (1997). Principles for the Selection of Doses in Chronic Rodent Bioassays. Foran JA (Ed.). ILSI Press, Washington, DC.
- (24) Griffiths SA, Parkinson C, McAuslane JAN and Lumley CE (1994). The utility of the second rodent species in the carcinogenicity testing of pharmaceuticals. *The Toxicologist* 14(1):214.
- (25) Usui T, Griffiths SA and Lumley CE (1996). The utility of the mouse for the assessment of the carcinogenic potential of pharmaceuticals. In D'Arcy POF & Harron DWG (eds). *Proceedings of the Third International Conference on Harmonisation*. Queen's University Press, Belfast. pp 279-284.
- (26) Carmichael NG, Enzmann H, Pate I, Waechter F (1997). The Significance of Mouse Liver Tumor Formation for Carcinogenic Risk Assessment: Results and Conclusions from a Survey of 10 Years of Testing by the Agrochemical Industry. *Environ Health Perspect.* 105:1196-1203.
- (27) Directive 2010/63/EU of the European Parliament and of the Council of 22 September 2010 on the protection of animals used for scientific purposes (OJ L 276, 20.10.2010, p. 33).
- (28) National Research Council, 1985. Guide for the care and use of laboratory animals. NIH Publication No 86-23. Washington, D.C., US Dept. of Health and Human Services.
- (29) GV-SOLAS (Society for Laboratory Animal Science, Gesellschaft für Versuchstierkunde, 1988). Publication on the Planning and Structure of Animal Facilities for Institutes Performing Animal Experiments. ISBN 3-906255-04-2.

- (30) GV-SOLAS (Society for Laboratory Animal Science, Gesellschaft für Versuchstierkunde, 2006). Microbiological monitoring of laboratory animals in various housing systems.
  - (31) Diehl K-H, Hull R, Morton D, Pfister R, Rabemampianina Y, Smith D, Vidal J-M, van de Vorstenbosch C. (2001). A good practice guide to the administration of substances and removal of blood, including routes and volumes. *Journal of Applied Toxicology* 21:15-23.
  - (32) Weingand K, *et al.* (1996). Harmonization of Animal Clinical Pathology Testing in Toxicity and Safety Studies. *Fund. Appl. Toxicol.* 29: 198-201.
  - (33) Crissman J, Goodman D, Hildebrandt P, *et al.* (2004). Best Practices Guideline: Toxicological Histopathology. *Toxicologic Pathology* 32: 126-131.
-

## Appendix 1

## DEFINITION

**Test chemical:** Any substance or mixture tested using this Test Method.

---

**B.33. COMBINED CHRONIC TOXICITY/CARCINOGENICITY STUDIES**

## INTRODUCTION

1. This Test Method is equivalent to OECD Test Guideline (TG) 453 (2009). The original TG 453 was adopted in 1981. Development of this updated Test Method B.33 was considered necessary, in order to reflect recent developments in the field of animal welfare and regulatory requirements (1) (2) (3) (4) (5). The updating of this Test Method B.33 has been carried out in parallel with revisions of Chapter B.32 of this Annex, Carcinogenicity Studies, and Chapter B.30 of this Annex, Chronic Toxicity Studies, with the objective of obtaining additional information from the animals used in the study and providing further detail on dose selection. This Test Method is designed to be used in the testing of a broad range of chemicals, including pesticides and industrial chemicals. It should be noted however that some details and requirements may differ for pharmaceuticals [see International Conference on Harmonisation (ICH) Guidance S1B on Testing for Carcinogenicity of Pharmaceuticals].
2. The majority of chronic toxicity and carcinogenicity studies are carried out in rodent species and this Test Method is intended therefore to apply primarily to studies carried out in these species. Should such studies be required in non-rodent species, the principles and procedures outlined may also be applied, with appropriate modifications, together with those outlined in Chapter B.27 of this Annex, Repeated Dose 90-day Oral Toxicity Study in Non-Rodents (6), as outlined in the OECD Guidance Document No 116 on the Design and Conduct of Chronic Toxicity and Carcinogenicity Studies (7).
3. The three main routes of administration used in chronic toxicity/carcinogenicity studies are oral, dermal and inhalation. The choice of the route of administration depends on the physical and chemical characteristics of the test chemical and the predominant route of exposure of humans. Additional information on choice of route of exposure is provided in Guidance Document No 116 (7).
4. This Test Method focuses on exposure via the oral route, the route most commonly used in chronic toxicity and carcinogenicity studies. While long-term studies involving exposure via the dermal or inhalation routes may also be necessary for human health risk assessment and/or may be required under certain regulatory regimes, both routes of exposure involve considerable technical complexity. Such studies will need to be designed on a case-by-case basis, although the Test Method outlined here for the assessment and evaluation of chronic toxicity and carcinogenicity by oral administration could form the basis of a protocol for inhalation and/or dermal studies, with respect to recommendations for treatment periods, clinical and pathology parameters, etc. OECD Guidance is available on the administration of test chemicals by the inhalation (7) (8) and dermal routes (7). Chapter B.8 of this Annex (9) and Chapter B.29 of this Annex (10), together with the OECD Guidance Document on acute inhalation testing (8), should be specifically consulted in the design of longer term studies involving exposure via the inhalation route. Chapter B.9 of this Annex (11) should be consulted in the case of testing carried out by the dermal route.
5. The combined chronic toxicity/carcinogenicity study provides information on the possible health hazards likely to arise from repeated exposure for a period lasting up to the entire lifespan of the species used. The study will provide information on the toxic effects of the test chemical, including potential carcinogenicity, indicate target organs and the possibility of accumulation. It can provide an estimate of the no-observed-adverse effect level for toxic effects and, in the case of non-genotoxic carcinogens, for tumour responses, which can be used for establishing safety criteria for human exposure. The need for careful clinical observations of the animals, so as to obtain as much information as possible, is also stressed.
6. The objectives of chronic toxicity/carcinogenicity studies covered by this Test Method include:
  - The identification of the carcinogenic properties of a test chemical, resulting in an increased incidence of neoplasms, increased proportion of malignant neoplasms or a reduction in the time to appearance of neoplasms, compared with concurrent control groups;
  - The identification of the time to appearance of neoplasms;
  - The identification of the chronic toxicity of the test chemical;

- The identification of target organ(s) of chronic toxicity and carcinogenicity,
- Characterisation of the dose:response relationship,
- Identification of a no-observed-adverse-effect level (NOAEL) or point of departure for establishment of a Benchmark Dose (BMD),
- Extrapolation of carcinogenic effects to low dose human exposure levels,
- Prediction of chronic toxicity effects at human exposure levels,
- Provision of data to test hypotheses regarding mode of action (2) (7) (12) (13) (14) (15).

#### INITIAL CONSIDERATIONS

7. In the assessment and evaluation of the potential carcinogenicity and chronic toxicity of a test chemical, all available information on the test chemical should be considered by the testing laboratory prior to conducting the study, in order to focus the design of the study to more efficiently test for its toxicological properties and to minimise animal usage. Information on, and consideration of, the mode of action of a suspected carcinogen (2) (7) (12) (13) (14) (15) is particularly important, since the optimal design may differ depending on whether the test chemical is a known or suspected genotoxic carcinogen. Further guidance on mode of action considerations can be found in Guidance Document No 116 (7).
8. Information that will assist in the study design includes the identity, chemical structure, and physico-chemical properties of the test chemical; any information on the mode of action; results of any *in vitro* or *in vivo* toxicity tests including genotoxicity tests; anticipated use(s) and potential for human exposure; available (Q)SAR data, mutagenicity/genotoxicity, carcinogenicity and other toxicological data on structurally-related chemicals; available toxicokinetic data (single dose and also repeat dose kinetics where available) and data derived from other repeated exposure studies. The determination of chronic toxicity/carcinogenicity should only be carried out after initial information on toxicity has been obtained from repeated dose 28-day and/or 90-day toxicity tests. Short-term cancer initiation-promotion tests could also provide useful information. A phased testing approach to carcinogenicity testing should be considered as part of the overall assessment of the potential adverse health effects of a particular test chemical (16) (17) (18) (19).
9. The statistical methods most appropriate for the analysis of results, given the experimental design and objectives, should be established before commencing the study. Issues to consider include whether the statistics should include adjustment for survival, analysis of cumulative tumour risks relative to survival duration, analysis of the time to tumour and analysis in the event of premature termination of one or more groups. Guidance on the appropriate statistical analyses and key references to internationally accepted statistical methods are given in Guidance Document No 116 (7), and also in Guidance Document No 35 on the analysis and evaluation of chronic toxicity and carcinogenicity studies (20).
10. In conducting a carcinogenicity study, the guiding principles and considerations outlined in the OECD Guidance Document on the recognition, assessment, and use of clinical signs as humane endpoints for experimental animals used in safety evaluation (21), in particular paragraph 62 thereof, should always be followed. This paragraph states that *"In studies involving repeated dosing, when an animal shows clinical signs that are progressive, leading to further deterioration in condition, an informed decision as to whether or not to humanely kill the animal should be made. The decision should include consideration as to the value of the information to be gained from the continued maintenance of that animal on study relative to its overall condition. If a decision is made to leave the animal on test, the frequency of observations should be increased, as needed. It may also be possible, without adversely affecting the purpose of the test, to temporarily stop dosing if it will relieve the pain or distress, or reduce the test dose."*
11. Detailed guidance on and discussion of the principles of dose selection for chronic toxicity and carcinogenicity studies can be found in Guidance Document No 116 (7), as well as two International Life Sciences Institute publications (22) (23). The core dose selection strategy is dependent on the primary objective or objectives of the study (paragraph 6). In selecting appropriate dose levels, a balance should be achieved between hazard screening on the one hand and characterisation of low-dose responses and their relevance on the other. This is particularly relevant in the case of this combined chronic toxicity and carcinogenicity study.



12. Consideration should be given to carrying out this combined chronic toxicity and carcinogenicity study, rather than separate execution of a chronic toxicity study (Chapter B.30 of this Annex) and carcinogenicity study (Chapter B.32 of this Annex). The combined test provides greater efficiency in terms of time and cost, and some reduction in animal use, compared to conducting two separate studies, without compromising the quality of the data in either the chronic phase or the carcinogenicity phase. Careful consideration should however be given to the principles of dose selection (paragraphs 11 and 22-26) when undertaking a combined chronic toxicity and carcinogenicity study, and it is also recognised that separate studies may be required under certain regulatory frameworks. Further guidance on the design of the combined chronic toxicity and carcinogenicity study in order to achieve maximum efficiency of the study in terms of possibilities for reduction in numbers of animals used as well as via the streamlining of the various experimental procedures can be found in Guidance Document No 116 (7).
13. Definitions used in the context of this Test Method can be found at the end of this chapter and in Guidance Document No 116 (7).

#### PRINCIPLE OF THE TEST

14. The study design consists of two parallel phases, a chronic phase and a carcinogenicity phase (for duration see paragraphs 34 and 35, respectively). The test chemical is normally administered by the oral route although testing by the inhalation or dermal route may also be appropriate. For the chronic phase, the test chemical is administered daily in graduated doses to several groups of test animals, one dose level per group, normally for a period of 12 months, although longer or shorter durations may also be chosen depending on regulatory requirements (see paragraph 34). This duration is chosen to be sufficiently long to allow any effects of cumulative toxicity to become manifest, without the confounding effects of geriatric changes. The study design may also include one or more interim kills, e.g. at 3 and 6 months, and additional groups of animals may be included to accommodate this (see paragraph 20). For the carcinogenicity phase, the test chemical is administered daily to several groups of test animals for a major portion of their life span. The animals in both phases are observed closely for signs of toxicity and for the development of neoplastic lesions. Animals which die or are killed during the test are necropsied and, at the conclusion of the test, surviving animals are killed and necropsied.

#### DESCRIPTION OF THE METHOD

##### **Selection of animal species**

15. This Test Method primarily covers assessment and evaluation of chronic toxicity and carcinogenicity in rodents (paragraph 2). The use of non-rodent species may be considered when available data suggest that they are more relevant for the prediction of health effects in humans. The choice of species should be justified. The preferred rodent species is the rat, although other rodent species, e.g. the mouse, may be used. Although the use of the mouse in carcinogenicity testing may have limited utility (24) (25) (26), under some current regulatory programmes carcinogenicity testing in the mouse is still required unless it is determined that such a study is not scientifically necessary. Rats and mice have been preferred experimental models because of their relatively short life span, their widespread use in pharmacological and toxicological studies, their susceptibility to tumour induction, and the availability of sufficiently characterised strains. As a consequence of these characteristics, a large amount of information is available on their physiology and pathology. The design and conduct of chronic toxicity/carcinogenicity studies in non-rodent species, when required, should be based on the principles outlined in this Test Method together with those in Chapter B.27 of this Annex, Repeated Dose 90-day Oral Toxicity Study in Non-Rodents (6). Additional information on choice of species and strain is provided in Guidance Document No 116 (7).
16. Young healthy adult animals of commonly used laboratory strains should be employed. The combined chronic toxicity/carcinogenicity study should be carried out in animals from the same strain and source as those used in preliminary toxicity study(ies) of shorter duration, although, if animals from this strain and source are known to present problems in achieving the normally accepted criteria of survival for long-term studies [see Guidance Document No 116 (7)], consideration should be given to using a strain of animal that has a acceptable survival rate for the long-term study. The females should be nulliparous and non-pregnant.

##### **Housing and feeding conditions**

17. Animals may be housed individually, or be caged in small groups of the same sex; individual housing should be considered only if scientifically justified (27) (28) (29). Cages should be arranged in such a way that possible effects due to cage placement are minimised. The temperature in the experimental animal room should be 22 °C ( $\pm$  3 °C). Although the relative humidity should be at least 30 % and preferably not exceed 70 % other than during room cleaning, the aim should be 50-60 %. Lighting should be artificial, the sequence being 12 hours light, 12 hours dark. For feeding, conventional laboratory diets may be used with an unlimited supply of drinking water. The diet should meet all the nutritional requirements of the species tested and the content of dietary contaminants, including but not limited to pesticide residues, persistent organic pollutants, phytoestrogens, heavy metals and mycotoxins, that might influence the outcome of the test, should be as low as possible. Analytical information on the nutrient and dietary contaminant levels should be generated periodically,

at least at the beginning of the study and when there is a change in the batch used, and should be included in the final report. Analytical information on the drinking water used in the study should similarly be provided. The choice of diet may be influenced by the need to ensure a suitable admixture of a test chemical and to meet the nutritional requirements of the animals when the test chemical is administered by the dietary route.

#### **Preparation of animals**

18. Healthy animals, which have been acclimated to laboratory conditions for at least 7 days and have not been subjected to previous experimental procedures, should be used. In the case of rodents, dosing of the animals should begin as soon as possible after weaning and acclimatisation and preferably before the animals are 8 weeks old. The test animals should be characterised as to species, strain, source, sex, weight and age. At the commencement of the study, the weight variation for each sex of animals used should be minimal and not exceed  $\pm 20\%$  of the mean weight of all the animals within the study, separately for each sex. Animals should be randomly assigned to the control and treatment groups. After randomisation, there should be no significant differences in mean body weights between groups within each sex. If there are statistically significant differences, then the randomisation step should be repeated, if possible. Each animal should be assigned a unique identification number, and permanently marked with this number by tattooing, microchip implant, or other suitable method.

#### **PROCEDURE**

##### **Number and sex of animals**

19. Both sexes should be used. A sufficient number of animals should be used so that a thorough biological and statistical evaluation is possible. For rodents, each dose group (as outlined in paragraph 22) and concurrent control group intended for the carcinogenicity phase of the study should therefore contain at least 50 animals of each sex. Depending on the aim of the study, it may be possible to increase the statistical power of the key estimates by differentially allocating animals unequally to the various dose groups, with more than 50 animals in the low dose groups, e.g. to estimate the carcinogenic potential in low doses. However it should be recognised that a moderate increase in group size will provide relatively little increase in statistical power of the study. Each dose group (as outlined in paragraph 22) and concurrent control group intended for the chronic toxicity phase of the study should contain at least 10 animals of each sex, in the case of rodents. It should be noted that this number is lower than in the chronic toxicity study (Chapter B.30 of this Annex). The interpretation of the data from the reduced number of animals per group in the chronic toxicity phase of this combined study will however be supported by the data from the larger number of animals in the carcinogenicity phase of the study. In studies involving mice, additional animals may be needed in each dose group of the chronic toxicity phase, to conduct all required haematological determinations. Further information on statistical design of the study and choice of dose levels to maximise statistical power is provided in Guidance Document No 116 (7).

##### **Provision for interim kills, satellite group and sentinel animals**

20. The study may make provision for interim kills, e.g. at 6 months for the chronic toxicity phase, to provide information on progression of non-neoplastic changes and mechanistic information, if scientifically justified. Where such information is already available from previous repeat dose toxicity studies on the test chemical, interim kills may not be scientifically justified. The animals used in the chronic toxicity phase of the study, normally of 12 months duration (paragraph 34) provide interim kill data for the carcinogenicity phase of the study, thus achieving a reduction in the number of animals used overall. Satellite groups may also be included in the chronic toxicity phase of the study, to monitor the reversibility of any toxicological changes induced by the test chemical under investigation. These may be restricted to the highest dose level of the study plus control. An additional group of sentinel animals (typically 5 animals per sex) may be included for monitoring of disease status, if necessary, during the study (30). Further guidance on study design to include interim kills, satellite and sentinel animals, while minimising the number of animals used overall is provided in Guidance Document No 116 (7).
21. If satellite animals and/or interim kills are included in the study design, the number of animals in each dose group included for this purpose will normally be 10 animals per sex, and the total number of animals included in the study design should be increased by the number of animals scheduled to be killed before the completion of the study. Interim kill and satellite animals should normally undergo the same observations, including body weight, food/water consumption, haematological and clinical biochemistry measurements and pathological investigations as the animals in the chronic toxicity phase of the main study, although provision may also be made (in the interim kill groups) for measurements to be restricted to specific, key measures such as neurotoxicity or immunotoxicity.

##### **Dose groups and dosage**

22. Guidance on all aspects of dose selection and dose level spacing is provided in Guidance Document No 116 (7). At least three dose levels and a concurrent control should be used, for both the chronic and carcinogenicity phases. Dose levels will generally be based on the results of shorter-term repeated dose or range finding studies and should take into account any existing toxicological and toxicokinetic data available for the test chemical or related chemicals.

23. For the chronic toxicity phase of the study, a full study using three dose levels may not be considered necessary, if it can be anticipated that a test at one dose level, equivalent to at least 1 000 mg/kg body weight/day, is unlikely to produce adverse effects. This should be based on information from preliminary studies and a consideration that toxicity would not be expected, based upon data from structurally related chemicals. A limit of 1 000 mg/kg body weight/day may apply except when human exposure indicates the need for a higher dose level to be used.
24. Unless limited by the physical-chemical nature or biological effects of the test chemical, the highest dose level should be chosen to identify the principal target organs and toxic effects while avoiding suffering, severe toxicity, morbidity, or death. The highest dose level should be normally chosen to elicit evidence of toxicity, as evidenced by, for example, depression of body weight gain (approximately 10 %). However, dependent on the objectives of the study (see paragraph 6), a top dose lower than the dose providing evidence of toxicity may be chosen, e.g. if a dose elicits an adverse effect of concern, which nonetheless has little impact on lifespan or body weight.
25. Dose levels and dose level spacing may be selected to establish a dose-response and, depending on the mode of action of the test chemical, a NOAEL or other intended outcome of the study, e.g. a BMD (see paragraph 27). Factors that should be considered in the placement of lower doses include the expected slope of the dose-response curve, the doses at which important changes may occur in metabolism or mode of toxic action, where a threshold is expected, or where a point of departure for low-dose extrapolation is expected. In conducting a combined carcinogenicity/chronic toxicity study, the primary objective will be to obtain information for carcinogenicity risk assessment purposes, and information on chronic toxicity will normally be a subsidiary objective. This should be borne in mind when selecting dose levels and dose level spacing for the study.
26. The dose level spacing selected will depend on the objectives of the study and the characteristics of the test chemical, and cannot be prescribed in detail in this Test Method, but two to four fold intervals frequently provide good test performance when used for setting the descending dose levels and addition of a fourth test group is often preferable to using very large intervals (e.g. more than a factor of about 6-10) between dosages. In general the use of factors greater than 10 should be avoided, and should be justified if used.
27. As outlined further in Guidance Document No 116 (7), points to be considered in dose selection include:
- Known or suspected nonlinearities or inflection points in the dose-response;
  - Toxicokinetics, and dose ranges where metabolic induction, saturation, or nonlinearity between external and internal doses does or does not occur;
  - Precursor lesions, markers of effect, or indicators of the operation of key underlying biological processes;
  - Key (or suspected) aspects of mode of action, such as doses at which cytotoxicity begins to arise, hormone levels are perturbed, homeostatic mechanisms are overwhelmed, etc.;
  - Regions of the dose-response curve where particularly robust estimation is needed, e.g. in the range of the anticipated BMD or a suspected threshold;
  - Consideration of anticipated human exposure levels, especially in the choice of mid and low doses.
28. The control group shall be an untreated group or a vehicle-control group if a vehicle is used in administering the test chemical. Except for treatment with the test chemical, animals in the control group should be handled in an identical manner to those in the test groups. If a vehicle is used, the control group shall receive the vehicle in the highest volume used among the dose groups. If a test chemical is administered in the diet, and causes significantly reduced dietary intake due to the reduced palatability of the diet, an additional pair-fed control group may be useful, to serve as a more suitable control.

#### **Preparation of doses and administration of test chemical**

29. The test chemical is normally administered orally, via the diet or drinking water, or by gavage. Additional information on routes and methods of administration is provided in Guidance Document No 116 (7). The route and method of administration is dependent on the purpose of the study, the physical/chemical properties of the test chemical, its bioavailability, and the predominant route and method of exposure of humans. A rationale should be provided for the chosen route and method of administration. In the interests of animal welfare, oral

gavage should normally be selected only for those agents for which this route and method of administration reasonably represent potential human exposure (e.g. pharmaceuticals). For dietary or environmental chemicals including pesticides, administration is typically via the diet or drinking water. However, for some scenarios, e.g. occupational exposure, administration via other routes may be more appropriate.

30. Where necessary, the test chemical is dissolved or suspended in a suitable vehicle. Consideration should be given to the following characteristics of the vehicle and other additives, as appropriate: effects on the absorption, distribution, metabolism, or retention of the test chemical; effects on the chemical properties of the test chemical which may alter its toxic characteristics; and effects on the food or water consumption or the nutritional status of the animals. It is recommended that, wherever possible, the use of an aqueous solution/suspension be considered first, followed by consideration of a solution/emulsion in oil (e.g. corn oil) and then by possible solution in other vehicles. For vehicles other than water, the toxic characteristics of the vehicle should be known. Information should be available on the stability of the test chemical and the homogeneity of dosing solutions or diets (as appropriate) under the conditions of administration (e.g. diet).
31. For chemicals administered via the diet or drinking water it is important to ensure that the quantities of the test chemical involved do not interfere with normal nutrition or water balance. In long-term toxicity studies using dietary administration, the concentration of the test chemical in the feed should not normally exceed an upper limit of 5 % of the total diet, in order to avoid nutritional imbalances. When the test chemical is administered in the diet, either a constant dietary concentration (mg/kg diet or ppm), or a constant dose level in terms of the animal's body weight (mg/kg body weight), calculated on a weekly basis, may be used. The alternative used should be specified.
32. In the case of oral administration, the animals are dosed with the test chemical daily (seven days each week) for a period of 12 months (chronic phase) or 24 months (carcinogenicity phase), see also paragraphs 33 and 34. Any other dosing regime, e.g. five days per week, needs to be justified. In the case of dermal administration, animals are normally treated with the test chemical for at least 6 hours per day, 7 days per week, as specified in Chapter B.9 of this Annex (11), for a period of 12 months (chronic phase) or 24 months (carcinogenicity phase). Exposure by the inhalation route is carried out for 6 hours per day, 7 days per week, but exposure for 5 days per week may also be used, if justified. The period of exposure will normally be for a period of 12 months (chronic phase) or 24 months (carcinogenicity phase). If rodent species other than rats are exposed nose-only, maximum exposure durations may be adjusted to minimise species-specific distress. A rationale should be provided when using an exposure duration of less than 6 hours per day. See also Chapter B.8 of this Annex (9).
33. When the test chemical is administered by gavage to the animals this should be done using a stomach tube or a suitable intubation cannula, at similar times each day. Normally a single dose will be administered once daily, where for example a chemical is a local irritant, it may be possible to maintain the daily dose-rate by administering it as a split dose (twice a day). The maximum volume of liquid that can be administered at one time depends on the size of the test animal. The volume should be kept as low as practical, and should not normally exceed 1 ml/100g body weight for rodents (31). Variability in test volume should be minimised by adjusting the concentration to ensure a constant volume at all dose levels. Potentially corrosive or irritant chemicals are the exception, and need to be diluted to avoid severe local effects. Testing at concentrations that are likely to be corrosive or irritant to the gastrointestinal tract should be avoided.

#### **Duration of study**

34. The period of dosing and duration of the chronic phase of this study is normally 12 months, although the study design also allows for and can be applied to either shorter (e.g. 6 or 9 months) or longer (e.g. 18 or 24 months) duration studies, depending on the requirements of particular regulatory regimes or for specific mechanistic purposes. Deviations from an exposure duration of 12 months should be justified, particularly in the case of shorter durations. All dose groups allocated to this phase will be terminated at the designated time for evaluation of chronic toxicity and non-neoplastic pathology. Satellite groups included to monitor the reversibility of any toxicological changes induced by the test chemical under investigation should be maintained without dosing for a period not less than 4 weeks and not more than one third of the total study duration after cessation of exposure.
35. The duration of the carcinogenicity phase of this study will normally be 24 months for rodents, representing the majority of the normal life span of the animals to be used. Shorter or longer study durations may be used, dependent on the lifespan of the strain of the animal species in the study, but should be justified. For specific strains of mice, e.g. AKR/J, C3H/J or C57BL/6J strains a duration of 18 months may be more appropriate. The

following provides some guidance on duration, termination of the study and survival; further guidance, including consideration of the acceptability of a negative carcinogenicity study relative to survival in the study, is provided in Guidance Document No 116 (7):

- Termination of the study should be considered when the number of survivors in the lower dose groups or the control group falls below 25 per cent.
  
- In the case where only the high dose group dies prematurely due to toxicity, this should not trigger termination of the study.
  
- Survival of each sex should be considered separately.
  
- The study should not be extended beyond the point when the data available from the study are no longer sufficient to enable a statistically valid evaluation to be made.

#### OBSERVATIONS (CHRONIC TOXICITY PHASE)

36. All animals should be checked for morbidity or mortality, usually at the beginning and end of each day, including at weekends and holidays. General clinical observations should be made at least once a day, preferably at the same time(s) each day, taking into consideration the peak period of anticipated effects after dosing in the case of gavage administration.
  
37. Detailed clinical observations should be made on all animals at least once prior to the first exposure (to allow for within-subject comparisons), at the end of the first week of the study and monthly thereafter. The protocol for observations should be arranged such that variations between individual observers are minimised and independent of test group. These observations should be made outside the home cage, preferably in a standard arena and at similar times on each occasion. They should be carefully recorded, preferably using scoring systems, explicitly defined by the testing laboratory. Efforts should be made to ensure that variations in the observation conditions are minimal. Signs noted should include, but not be limited to, changes in skin, fur, eyes, mucous membranes, occurrence of secretions and excretions and autonomic activity (e.g. lacrimation, piloerection, pupil size, unusual respiratory pattern). Changes in gait, posture and response to handling as well as the presence of clonic or tonic movements, stereotypies (e.g. excessive grooming, repetitive circling) or bizarre behaviour (e.g. self-mutilation, walking backwards) should also be recorded (32).
  
38. Ophthalmological examination, using an ophthalmoscope or other suitable equipment, should be carried out on all animals prior to the first administration of the test chemical. At the termination of the study, this examination should be preferably conducted in all animals but at least in the high dose and control groups. If treatment-related changes in the eyes are detected, all animals should be examined. If structural analysis or other information suggests ocular toxicity, then the frequency of ocular examination should be increased.
  
39. For chemicals where previous repeated dose 28-day and/or 90-day toxicity tests indicated the potential to cause neurotoxic effects, sensory reactivity to stimuli of different types (32) (e.g. auditory, visual and proprioceptive stimuli) (33) (34) (35), assessment of grip strength (36) and motor activity assessment (37) may optionally be conducted before commencement of the study and at 3 month periods after study initiation up to and including 12 months, as well as at study termination (if longer than 12 months). Further details of the procedures that could be followed are given in the respective references. However, alternative procedures than those referenced could also be used.
  
40. For chemicals where previous repeated dose 28-day and/or 90-day toxicity tests indicated the potential to cause immunotoxic effects, further investigations of this endpoint may optionally be conducted at termination.

#### *Body weight, food/water consumption and food efficiency*

41. All animals should be weighed at the start of treatment, at least once a week for the first 13 weeks and at least monthly thereafter. Measurements of food consumption and food efficiency should be made at least weekly for the first 13 weeks and at least monthly thereafter. Water consumption should be measured at least weekly for the first 13 weeks and at least monthly thereafter when the test chemical is administered in drinking water. Water consumption measurements should also be considered for studies in which drinking activity is altered.



*Haematology and clinical biochemistry*

42. In studies involving rodents, haematological examinations should be carried out on all study animals (10 male and 10 female animals per group) at 3, 6, and 12 months, as well as at study termination (if longer than 12 months). In mice, satellite animals may be needed in order to conduct all required haematological determinations (see paragraph 19). In non-rodent studies, samples will be taken from smaller numbers of animals (e.g. 4 animals per sex and per group in dog studies), at interim sampling times and at termination as described for rodents. Measurements at 3 months, either in rodents or non-rodents, need not be conducted if no effect was seen on haematological parameters in a previous 90 day study carried out at comparable dose levels. Blood samples should be taken from a named site, for example by cardiac puncture or from the retro-orbital sinus, under anaesthesia.
43. The following list of parameters should be investigated (38): total and differential leukocyte count, erythrocyte count, platelet count, haemoglobin concentration, haematocrit (packed cell volume), mean corpuscular volume (MCV), mean corpuscular haemoglobin (MCH), mean corpuscular haemoglobin concentration (MCHC), prothrombin time, and activated partial thromboplastin time. Other hematology parameters such as Heinz bodies or other atypical erythrocyte morphology or methaemoglobin may be measured as appropriate depending on the toxicity of the test chemical. Overall, a flexible approach should be adopted, depending on the observed and/or expected effect from a given test chemical. If the test chemical has an effect on the haematopoietic system, reticulocyte counts and bone marrow cytology may also be indicated, although these need not be routinely conducted.
44. Clinical biochemistry determinations to investigate major toxic effects in tissues and, specifically, effects on kidney and liver, should be performed on blood samples obtained from all study animals (10 male and 10 female animals per group), at the same time intervals as specified for the haematological investigations. In mice, satellite animals may be needed in order to conduct all required clinical biochemistry determinations. In non-rodent studies, samples will be taken from smaller numbers of animals (e.g. 4 animals per sex and per group in dog studies), at interim sampling times and at termination as described for rodents. Measurements at 3 months, either in rodents or non-rodents, need not be conducted if no effect was seen on clinical biochemistry parameters in a previous 90 day study carried out at comparable dose levels. Overnight fasting of the animals (with the exception of mice) prior to blood sampling is recommended<sup>(1)</sup>. The following list of parameters should be investigated (38): glucose, urea (urea nitrogen), creatinine, total protein, albumin, calcium, sodium, potassium, total cholesterol, at least two appropriate tests for hepatocellular evaluation (alanine aminotransferase, aspartate aminotransferase, glutamate dehydrogenase, total bile acids) (39), and at least two appropriate tests for hepatobiliary evaluation (alkaline phosphatase, gamma glutamyl transferase, 5'-nucleotidase, total bilirubin, total bile acids) (39). Other clinical chemistry parameters such as fasting triglycerides, specific hormones and cholinesterase may be measured as appropriate, depending on the toxicity of the test chemical. Overall, there is a need for a flexible approach, depending on the observed and/or expected effect from a given test chemical.
45. Urinalysis determinations should be performed on all study animals (10 male and 10 female animals per group), on samples collected at the same intervals as for haematology and clinical chemistry. Measurements at 3 months need not be conducted if no effect was seen on urinalysis in a previous 90 day study carried out at comparable dose levels. The following list of parameters was included in an expert recommendation on clinical pathology studies (38): appearance, volume, osmolality or specific gravity, pH, total protein, and glucose. Other determinations include ketone, urobilinogen, bilirubin, and occult blood. Further parameters may be employed where necessary to extend the investigation of observed effect(s).
46. It is generally considered that baseline haematological and clinical biochemistry variables need be determined before treatment for dog studies, but need not be determined in rodent studies (38). However, if historical baseline data (see paragraph 58) are inadequate, consideration should be given to generating such data.

## PATHOLOGY

*Gross necropsy*

47. All animals in the study shall be normally subjected to a full, detailed gross necropsy which includes careful examination of the external surface of the body, all orifices, and the cranial, thoracic and abdominal cavities and their contents. However provision may also be made (in the interim kill or satellite groups) for measurements to be restricted to specific, key measures such as neurotoxicity or immunotoxicity (see paragraph 21). These animals need not be subjected to necropsy and the subsequent procedures described in the following paragraphs. Sentinel animals may require necropsy on a case-by-case basis, at the discretion of the study director.

<sup>(1)</sup> For a number of measurements in serum and plasma, most notably for glucose, overnight fasting is preferable. The major reason for this preference is that the increased variability which would inevitably result from non-fasting, would tend to mask more subtle effects and make interpretation difficult. However it should be noted that overnight fasting may interfere with the general metabolism of the animals and, particularly in feeding studies, may disrupt the daily exposure to the test chemical. All animals should be assessed in the same physiological condition and preferably detailed or neurological assessments should therefore be scheduled for a different day than clinical biochemistry sampling.

48. Organ weights should be collected from all animals, other than those excluded by the latter part of paragraph 47. The adrenals, brain, epididymides, heart, kidneys, liver, ovaries, spleen, testes, thyroid (weighed post-fixation, with parathyroids), and uterus of all animals (apart from those found moribund and/or intercurrently killed) should be trimmed of any adherent tissue, as appropriate, and their wet weight taken as soon as possible after dissection to prevent drying.
49. The following tissues should be preserved in the most appropriate fixation medium for both the type of tissue and the intended subsequent histopathological examination (40) (tissues in square brackets are optional):

all gross lesions	heart	pancreas	stomach (forestomach, glandular stomach)
adrenal gland	ileum	parathyroid gland	[teeth]
aorta	jejunum	peripheral nerve	testis
brain (including sections of cerebrum, cerebellum, and medulla/pons)	kidney	pituitary	thymus
caecum	lacrimal gland (exorbital)	prostate	thyroid
cervix	liver	rectum	[tongue]
coagulating gland	lung	salivary gland	trachea
colon	lymph nodes (both superficial and deep)	seminal vesicle	urinary bladder
duodenum	mammary gland (obligatory for females and, if visibly dissectable, from males)	skeletal muscle	uterus (including cervix)
epididymis	[upper respiratory tract, including nose, turbinates, and paranasal sinuses]	skin	[ureter]
eye (including retina)	oesophagus	spinal cord (at three levels: cervical, mid-thoracic, and lumbar)	[urethra]
[femur with joint]	[olfactory bulb]	spleen	vagina
gall bladder (for species other than rat)	ovary	[sternum],	section of bone marrow and/or a fresh bone marrow aspirate
Harderian gland			

In the case of paired organs, e.g. kidney, adrenal, both organs should be preserved. The clinical and other findings may suggest the need to examine additional tissues. Also any organs considered likely to be target organs based on the known properties of the test chemical should be preserved. In studies involving the dermal route of administration, the list of organs as set out for the oral route should be examined, and specific sampling and preservation of the skin from the site of application is necessary. In inhalation studies, the list of preserved and examined tissues from the respiratory tract should follow the recommendations of Chapters B.8 of this Annex (9) and Chapter B.29 of this Annex (10). For other organs/tissues (and in addition to the specifically preserved tissues from the respiratory tract) the list of organs as set out for the oral route should be examined.

#### *Histopathology*

50. Guidance is available on best practices in the conduct of toxicological pathology studies (40). The minimum histopathological examinations should be:

— all tissues from the high dose and control groups;

- all tissues from animals dying or killed during the study;
- all tissues showing macroscopic abnormalities;
- target tissues, or tissues which showed treatment-related changes in the high dose group, from all animals in all other dose groups,
- in the case of paired organs, e.g. kidney, adrenal, both organs should be examined.

#### OBSERVATIONS (CARCINOGENICITY PHASE)

51. All animals should be checked for morbidity or mortality, usually at the beginning and the end of each day, including at weekends and holidays. Animals should additionally be checked once a day for specific signs of toxicological relevance. In the case of gavage studies, animals should be checked in the period immediately following dosing. Particular attention should be paid to tumour development; and the time of tumour onset, location, dimensions, appearance, and progression of each grossly visible or palpable tumour should be recorded.
52. All animals should be weighed at the start of treatment, at least once a week for the first 13 weeks and at least monthly thereafter. Measurements of food consumption and food efficiency should be made at least weekly for the first 13 weeks and at least monthly thereafter. Water consumption should be measured at least weekly for the first 13 weeks and at least monthly thereafter when the test chemical is administered in drinking water. Water consumption measurements should also be considered for studies in which drinking activity is altered.

#### *Haematology, clinical biochemistry and other measurements*

53. In order to maximise the information obtained from the study, especially for mode of action considerations, blood samples may be taken for haematology and clinical biochemistry, although this is at the discretion of the study director. Urinalysis may also be appropriate. Data on the animals used in the chronic toxicity phase of the study, normally of 12 months duration (paragraph 34) will provide information on these parameters. Further guidance on the value of taking such samples as part of a carcinogenicity study is provided in Guidance Document No 116 (7). If blood samples are taken, these should be collected at the end of the test period, just prior to or as part of the procedure for killing the animals. They should be taken from a named site, for example by cardiac puncture or from the retro-orbital sinus, under anaesthesia. Blood smears may also be prepared for examination, particularly if bone marrow appears to be the target organ, although the value of such examination of blood smears in the carcinogenicity phase for the assessment of carcinogenic/oncogenic potential has been questioned (38).

#### PATHOLOGY

##### *Gross necropsy*

54. All animals in the study except sentinel animals and other satellite animals (see paragraph 20) shall be subjected to a full, detailed gross necropsy which includes careful examination of the external surface of the body, all orifices, and the cranial, thoracic and abdominal cavities and their contents. Sentinel animals and other satellite animals may require necropsy on a case-by-case basis, at the discretion of the study director. Organ weights are not normally part of a carcinogenesis study, since geriatric changes and, at later stages, the development of tumours confounds the usefulness of organ weight data. They may, however, be critical to performing a weight of evidence evaluation and especially for mode of action considerations. If they are part of a satellite study, they should be collected at no later than one year after initiation of the study.
55. The following tissues should be preserved in the most appropriate fixation medium for both the type of tissue and the intended subsequent histopathological examination (40) (tissues in square brackets are optional):

all gross lesions	heart	pancreas	stomach (forestomach, glandular stomach)
adrenal gland	ileum	parathyroid gland	[teeth]
aorta	jejunum	peripheral nerve	testis
brain (including sections of cerebrum, cerebellum, and medulla/pons)	kidney	pituitary	thymus
caecum	lacrimal gland (exorbital)	prostate	thyroid



cervix	liver	rectum	[tongue]
coagulating gland	lung	salivary gland	trachea
colon	lymph nodes (both superficial and deep)	seminal vesicle	urinary bladder
duodenum	mammary gland (obligatory for females and, if visibly dissectable, from males)	skeletal muscle	uterus (including cervix)
epididymis	[upper respiratory tract, including nose, turbinates, and paranasal sinuses]	skin	[ureter]
eye (including retina)	oesophagus	spinal cord (at three levels: cervical, mid-thoracic, and lumbar)	[urethra]
[femur with joint]	[olfactory bulb]	spleen	vagina
gall bladder (for species other than rat)	ovary	[sternum],	section of bone marrow and/or a fresh bone marrow aspirate
Harderian gland			

In the case of paired organs, e.g. kidney, adrenal, both organs should be preserved. The clinical and other findings may suggest the need to examine additional tissues. Also, any organs considered likely to be target organs based on the known properties of the test chemical should be preserved. In studies involving the dermal route of administration, the list of organs as set out for the oral route should be examined, and specific sampling and preservation of the skin from the site of application is necessary. In inhalation studies, the list of preserved and examined tissues from the respiratory tract should follow the recommendations of Chapters B.8 of this Annex (8) and Chapter B.29 of this Annex (9). For other organs/tissues (and in addition to the specifically preserved tissues from the respiratory tract) the list of organs as set out for the oral route should be examined.

#### *Histopathology*

56. Guidance is available on best practices in the conduct of toxicological pathology studies (40). The minimum tissues examined should be:

- All tissues from the high dose and control groups;
- All tissues of animals dying or killed during the study;
- All tissues showing macroscopic abnormalities including tumours;
- When treatment-related histopathological changes are observed in the high dose group, those same tissues are to be examined from all animals in all other dose groups,
- In the case of paired organs, e.g. kidney, adrenal, both organs should be examined.

#### DATA AND REPORTING (CARCINOGENICITY AND CHRONIC TOXICITY)

##### **Data**

57. Individual animal data should be provided for all parameters evaluated. Additionally, all data should be summarised in tabular form showing for each test group the number of animals at the start of the test, the number of animals found dead during the test or killed for humane reasons and the time of any death or humane kill, the number showing signs of toxicity, a description of the signs of toxicity observed, including time of onset, duration, and severity of any toxic effects, the number of animals showing lesions, the type of lesions and the percentage of animals displaying each type of lesion. Summary data tables should provide the means and standard deviations (for continuous test data) of animals showing toxic effects or lesions, in addition to the grading of lesions.

58. Historical control data may be valuable in the interpretation of the results of the study, e.g. in the case when there are indications that the data provided by the concurrent controls are substantially out of line when compared to recent data from control animals from the same test facility/colony. Historical control data, if evaluated, should be submitted from the same laboratory, relate to animals of the same age and strain, generated during the five years preceding the study in question.
59. When applicable, numerical results should be evaluated by an appropriate and generally acceptable statistical method. The statistical methods and the data to be analysed should be selected during the design of the study (paragraph 9). Selection should make provision for survival adjustments, if needed.
60. The test report should include the following information:

*Test chemical:*

- physical nature, purity, and physicochemical properties;
- identification data;
- source of chemical;
- batch number;
- certificate of chemical analysis.

*Vehicle (if appropriate):*

- justification for choice of vehicle (if other than water).

*Test animals:*

- species/strain used and justification for choice made;
- number, age, and sex of animals at start of test;
- source, housing conditions, diet, etc.;
- individual weights of animals at the start of the test.

*Test conditions:*

- rationale for route of administration and dose selection;
- when applicable, the statistical methods used to analyse the data;
- details of test chemical formulation/diet preparation;
- analytical data on achieved concentration, stability and homogeneity of the preparation;
- route of administration and details of the administration of the test chemical;
- for inhalation studies, whether nose only or whole body;
- actual doses (mg/kg body weight/day), and conversion factor from diet/drinking water test chemical concentration (mg/kg or ppm) to the actual dose, if applicable;
- details of food and water quality.

*Results (summary tabulated data and individual animal data should be presented):*

*General*

- Survival data;
- Body weight/body weight changes;
- Food consumption, calculations of food efficiency, if made, and water consumption if applicable;
- Toxicokinetic data if available;
- Ophthalmoscopy (if available)
- Haematology (if available)
- Clinical chemistry (if available)

*Clinical findings*

- Signs of toxicity;
- Incidence (and, if scored, severity) of any abnormality;
- Nature, severity, and duration of clinical observations (whether transitory or permanent);

*Necropsy data*

- Terminal body weight;
- Organ weights and their ratios, if applicable;
- Necropsy findings; Incidence and severity of abnormalities.

*Histopathology*

- Non neoplastic histopathological findings,
- Neoplastic histopathological findings,
- Correlation between gross and microscopic findings
- Detailed description of all treatment-related histopathological findings including severity gradings;
- Report of any peer review of slides

*Statistical treatment of results, as appropriate*

*Discussion of results including:*

- Discussion of any modelling approaches
- Dose:response relationships
- Historical control data

— Consideration of any mode of action information

— BMD, NOAEL or LOAEL determination

— Relevance for humans

*Conclusions*

**LITERATURE:**

- (1) OECD (1995). Report of the Consultation Meeting on Sub-chronic and Chronic Toxicity/Carcinogenicity Testing (Rome, 1995), internal working document, Environment Directorate, OECD, Paris.
- (2) EPA (2005). Guidelines for Carcinogen Risk Assessment Risk Assessment Forum U.S. Environmental Protection Agency Washington, DC.
- (3) Combes RD, Gaunt I, Balls M (2004). A Scientific and Animal Welfare Assessment of the OECD Health Effects Test Guidelines for the Safety Testing of Chemicals under the European Union REACH System. ATLA 32: 163-208
- (4) Barlow SM, Greig JB, Bridges JW et al (2002). Hazard identification by methods of animal-based toxicology. Food. Chem. Toxicol. 40: 145-191
- (5) Chhabra RS, Bucher JR, Wolfe M, Portier C (2003). Toxicity characterization of environmental chemicals by the US National Toxicology Programme: an overview. Int. J. Hyg. Environ. Health 206: 437-445
- (6) Chapter B.27 of this Annex, Sub-Chronic Oral Toxicity Test Repeated Dose 90 — Day Oral Toxicity Study In Non-Rodents.
- (7) OECD (2012). Guidance Document on the Design and Conduct of Chronic Toxicity and Carcinogenicity Studies, Supporting Test Guidelines 451, 452 and 453 — Second edition. Series on Testing and Assessment No 116, available on the OECD public website for Test Guideline at [www.oecd.org/env/testguidelines](http://www.oecd.org/env/testguidelines).
- (8) OECD (2009). Guidance Document on Acute Inhalation Toxicity Testing. Series on Testing and Assessment No 39, ENV/JM/MONO(2009)28, OECD, Paris.
- (9) Chapter B.8 of this Annex. Subacute Inhalation Toxicity: 28-Day Study.
- (10) Chapter B.29 of this Annex, Subchronic Inhalation Toxicity: 90-Day Study.
- (11) Chapter B.9 of this Annex, Repeated Dose (28 Days) Toxicity (Dermal).
- (12) Boobis AR, Cohen SM, Dellarco V, McGregor D, Meek ME, Vickers C, Willcocks D, Farland W (2006). IPCS Framework for analyzing the Relevance of a Cancer Mode of Action for Humans. Crit. Rev. in Toxicol, 36: 793-801.
- (13) Cohen SM, Meek ME, Klaunig JE, Patton DE, Fenner-Crisp PA (2003). The human relevance of information on carcinogenic Modes of Action: An Overview. Crit. Rev. Toxicol. 33: 581-589.
- (14) Holsapple MP, Pitot HC, Cohen SN, Boobis AR, Klaunig JE, Pastoor T, Dellarco VL, Dragan YP (2006). Mode of Action in Relevance of Rodent Liver Tumors to Human Cancer Risk. Toxicol. Sci. 89: 51-56.
- (15) Meek EM, Bucher JR, Cohen SM, Dellarco V, Hill RN, Lehman-McKemmon LD, Longfellow DG, Pastoor T, Seed J, Patton DE (2003). A Framework for Human Relevance analysis of Information on Carcinogenic Modes of Action. Crit. Rev. Toxicol. 33: 591-653.
- (16) Carmichael NG, Barton HA, Boobis AR *et al.* (2006). Agricultural Chemical Safety Assessment: A Multisector Approach to the Modernization of Human Safety Requirements. Crit. Rev. Toxicol. 36, 1-7.

- (17) Barton HA, Pastoor TP, Baetcke T *et al.* (2006). The Acquisition and Application of Absorption, Distribution, Metabolism, and Excretion (ADME) Data in Agricultural Chemical Safety Assessments. *Crit. Rev. Toxicol.* 36: 9-35.
- (18) Doe JE, Boobis AR, Blacker A *et al.* (2006). A Tiered Approach to Systemic Toxicity Testing for Agricultural Chemical Safety Assessment. *Crit. Rev. Toxicol.* 36: 37-68.
- (19) Cooper RL, Lamb JS, Barlow SM *et al.* (2006). A Tiered Approach to Life Stages Testing for Agricultural Chemical Safety Assessment. *Crit. Rev. Toxicol.* 36: 69-98.
- (20) OECD (2002). Guidance Notes for Analysis and Evaluation of Chronic Toxicity and Carcinogenicity Studies, Series on Testing and Assessment No 35 and Series on Pesticides No 14, ENV/JM/MONO(2002)19, OECD, Paris.
- (21) OECD (2000). Guidance Document on the recognition, assessment, and use of clinical signs as humane endpoints for experimental animals used in safety evaluation, Series on Testing and Assessment No 19, ENV/JM/MONO(2000)7, OECD, Paris.
- (22) Rhomberg LR, Baetcke K, Blancato J, Bus J, Cohen S, Conolly R, Dixit R, Doe J, Ekelman K, Fenner-Crisp P, Harvey P, Hattis D, Jacobs A, Jacobson-Kram D, Lewandowski T, Liteplo R, Pelkonen O, Rice J, Somers D, Turturro A, West W, Olin S (2007). Issues in the Design and Interpretation of Chronic Toxicity and Carcinogenicity Studies in Rodents: Approaches to Dose Selection *Crit Rev. Toxicol.* 37 (9): 729 – 837.
- (23) ILSI (International Life Sciences Institute) (1997). Principles for the Selection of Doses in Chronic Rodent Bioassays. Foran JA (Ed.). ILSI Press, Washington, DC.
- (24) Griffiths SA, Parkinson C, McAuslane JAN and Lumley CE (1994). The utility of the second rodent species in the carcinogenicity testing of pharmaceuticals. *The Toxicologist* 14(1):214.
- (25) Usui T, Griffiths SA and Lumley CE (1996). The utility of the mouse for the assessment of the carcinogenic potential of pharmaceuticals. In D'Arcy POF & Harron DWG (eds). *Proceedings of the Third International Conference on Harmonisation*. Queen's University Press, Belfast. pp 279-284.
- (26) Carmichael NG, Enzmann H, Pate I, Waechter F (1997). The Significance of Mouse Liver Tumor Formation for Carcinogenic Risk Assessment: Results and Conclusions from a Survey of 10 Years of Testing by the Agrochemical Industry. *Environ Health Perspect* 105:1196-1203.
- (27) Directive 2010/63/EU of the European parliament and of the Council of 22 September 2010 on the protection of animals used for scientific purposes (OJ L 276, 20.10.2010, p. 33).
- (28) National Research Council, 1985. Guide for the care and use of laboratory animals. NIH Publication No 86-23. Washington D.C., US. Dept. of Health and Human Services.
- (29) GV-SOLAS (Society for Laboratory Animal Science, Gesellschaft für Versuchstierkunde, December, 1989). Publication on the Planning and Structure of Animal Facilities for Institutes Performing Animal Experiments. ISBN 3-906255-06-9.
- (30) GV-SOLAS (Society for Laboratory Animal Science, Gesellschaft für Versuchstierkunde, 2006). Microbiological monitoring of laboratory animals in various housing systems.
- (31) Diehl K-H, Hull R, Morton D, Pfister R, Rabemampianina Y, Smith D, Vidal J-M, van de Vorstenbosch C. (2001). A good practice guide to the administration of substances and removal of blood, including routes and volumes. *Journal of Applied Toxicology*, 21: 15-23.
- (32) IPCS (1986). Principles and Methods for the Assessment of Neurotoxicity Associated with Exposure to Chemicals. Environmental Health Criteria Document No 60.
- (33) Tupper DE, Wallace RB (1980). Utility of the Neurologic Examination in Rats. *Acta Neurobiol. Exp.* 40: 999-1003.

- 
- (34) Gad SC (1982). A Neuromuscular Screen for Use in Industrial Toxicology. *J. Toxicol. Environ. Health* 9: 691-704.
- (35) Moser VC, McDaniel KM, Phillips PM (1991). Rat Strain and Stock Comparisons Using a Functional Observational Battery: Baseline Values and Effects of Amitraz. *Toxicol. Appl. Pharmacol.* 108: 267-283.
- (36) Meyer OA, Tilson HA, Byrd WC, Riley MT (1979). A Method for the Routine Assessment of Fore- and Hind-limb Grip Strength of Rats and Mice. *Neurobehav. Toxicol.* 1: 233-236.
- (37) Crofton KM, Howard JL, Moser VC, Gill MW, Reiter LW, Tilson HA, MacPhail RC (1991). Interlaboratory Comparison of Motor Activity Experiments: Implication for Neurotoxicological Assessments. *Neurotoxicol. Teratol.* 13: 599-609.
- (38) Weingand K, Brown G, Hall R *et al.* (1996). Harmonisation of Animal Clinical Pathology Testing in Toxicity and Safety Studies. *Fundam. & Appl. Toxicol.* 29: 198-201.
- (39) EMEA (draft) document "Non-clinical guideline on drug-induced hepatotoxicity" (Doc. Ref. EMEA/CHMP/SWP/a50115/2006).
- (40) Crissman JW, Goodman DG, Hildebrandt PK *et al.* (2004). Best Practices Guideline: Toxicological Histopathology. *Toxicologic Pathology* 32: 126-131.
-

## Appendix 1

## DEFINITION

**Test chemical:** Any substance or mixture tested using this Test Method.'

---

(7) Chapter B.36 is replaced by the following:

**'B.36. TOXICOKINETICS**

## INTRODUCTION

1. This Test Method is equivalent to OECD TG 417 (2010). Studies examining the toxicokinetics (TK) of a test chemical are conducted to obtain adequate information on its absorption, distribution, biotransformation (i.e. metabolism) and excretion, to aid in relating concentration or dose to the observed toxicity, and to aid in understanding its mechanism of toxicity. TK may help to understand the toxicology studies by demonstrating that the test animals are systemically exposed to the test chemical and by revealing which are the circulating moieties (parent chemical/metabolites). Basic TK parameters determined from these studies will also provide information on the potential for accumulation of the test chemical in tissues and/or organs and the potential for induction of biotransformation as a result of exposure to the test chemical.
2. TK data can contribute to the assessment of the adequacy and relevance of animal toxicity data for extrapolation to human hazard and/or risk assessment. Additionally, toxicokinetic studies may provide useful information for determining dose levels for toxicity studies (linear vs. non-linear kinetics), route of administration effects, bioavailability, and issues related to study design. Certain types of TK data can be used in physiologically based toxicokinetic (PBTK) model development.
3. There are important uses for metabolite/TK data such as suggesting possible toxicities and modes of action and their relation to dose level and route of exposure. In addition, metabolism data can provide information useful for assessing the toxicological significance of exposures to exogenously produced metabolites of the test chemical.
4. Adequate toxicokinetic data will be helpful to support the further acceptability and applicability of quantitative structure-activity relationships, read-across or grouping approaches in the safety evaluation of chemicals. Kinetics data may also be used to evaluate the toxicological relevance of other studies (e.g. *in vivo/in vitro*).
5. Unless another route of administration is mentioned (see in particular paragraphs 74-78), this Test Method is applicable to oral administration of the test chemical.

## INITIAL CONSIDERATIONS

6. Regulatory systems have different requirements and needs regarding the measurement of endpoints and parameters related to toxicokinetics for different classes of chemicals (e.g. pesticides, biocides, industrial chemicals). Unlike most Test Methods this Test Method describes toxicokinetics testing, which involves multiple measurements and endpoints. In the future, several new Test Methods, and/or guidance document(s), may be developed to describe each endpoint separately and in more detail. In the case of this Test Method, which tests or assessments are conducted is specified by the requirements and/or needs of each regulatory system.
7. There are numerous studies that might be performed to evaluate the TK behaviour of a test chemical for regulatory purposes. However, depending on particular regulatory needs or situations, not all of these possible studies may be necessary for the evaluation of a test chemical. Flexibility, taking into consideration the characteristics of the test chemical being investigated, is needed in the design of toxicokinetic studies. In some cases, only a certain set of questions may need to be explored in order to address test chemical-associated hazard and risk concerns. In some situations, TK data can be collected as part of the evaluation in other toxicology studies. For other situations, additional and/or more extensive TK studies may be necessary, depending on regulatory needs and/or if new questions arise as part of test chemical evaluation.
8. All available information on the test chemical and relevant metabolites and analogues should be considered by the testing laboratory prior to conducting the study in order to enhance study quality and avoid unnecessary animal use. This could include data from other relevant Test Methods (*in vivo* studies, *in vitro* studies, and/or *in silico* evaluations). Physicochemical properties, such as octanol-water partition coefficient (expressed as



log  $P_{OW}$ ), pKa, water solubility, vapour pressure, and molecular weight of a chemical may be useful for study planning and interpretation of results. They can be determined using appropriate methods as described in the relevant Test Methods.

#### LIMITATIONS

9. This Test Method is not designed to address special circumstances, such as the pregnant or lactating animal and offspring, or to evaluate potential residues in exposed food-producing animals. However, the data obtained from a B.36 study can provide background information to guide the design of specific studies for these investigations. This Test Method is not intended for the testing of nanomaterials. A report on preliminary review of OECD Test Guidelines for their applicability to nanomaterials indicates that TG 417 (equivalent to this Test Method B.36) may not apply to nanomaterials (1).

#### DEFINITIONS

10. Definitions used for the purpose of this Test Method are provided in Appendix.

#### ANIMAL WELFARE CONSIDERATIONS

11. Guidance on humane treatment of animals is available in OECD Guidance Document (GD) 19 (2). It is recommended that OECD GD 19 be consulted for all *in vivo* and *in vitro* studies described in this Test Method.

#### DESCRIPTION OF THE METHODS

##### **Pilot Studies**

12. The use of pilot studies is recommended and encouraged for the selection of experimental parameters for the toxicokinetics studies (e.g. metabolism, mass balance, analytical procedures, dose-finding, exhalation of CO<sub>2</sub>, etc.). Characterisation of some of these parameters may not necessitate the use of radiolabelled chemicals.

##### **Animal Selection**

###### *Species*

13. The animal species (and strain) used for TK testing should preferably be the same as that used in other toxicological studies performed with the test chemical of interest. Normally, the rat should be used as it has been used extensively for toxicological studies. The use of other or additional species may be warranted if critical toxicology studies demonstrate evidence of significant toxicity in these species or if their toxicity/toxicokinetics is shown to be more relevant to humans. Justification should be provided for the selection of the animal species and its strain.
14. Unless mentioned otherwise, this Test Method refers to the rat as the test species. Certain aspects of the method might have to be modified for the use of other test species.

###### *Age and Strain*

15. Young healthy adult animals (normally 6-12 weeks at the time of dosing) should be used (see also paragraphs 13 and 14). Justification should be provided for the use of animals that are not young adults. All animals should be of similar age at the outset of the study. The weight variation of individual animals should not exceed  $\pm 20\%$  of the mean weight of the test group. Ideally, the strain used should be the same as that used in deriving the toxicological database for the test chemical.

###### *Number and Sex of Animals*

16. A minimum of four animals of one sex should be used for each dose tested. Justification should be provided for the sex of the animals used. The use of both sexes (four males and four females) should be considered if there is evidence to support significant sex-related differences in toxicity.

###### *Housing and feeding conditions*

17. Animals should generally be housed individually during the testing period. Group housing might be justified in special circumstances. Lighting should be artificial, the sequence being 12 h light/12 h dark. The temperature of the experimental animal room should be 22 °C ( $\pm 3$  °C) and the relative humidity 30-70 %. For feeding, conventional laboratory diets may be used with an unlimited supply of drinking water.

### Test Chemical

18. A radiolabelled test chemical using  $^{14}\text{C}$  should be used for all mass balance and metabolite identification aspects of the study; however, if it can be demonstrated that:
- mass balance and metabolite identification can be adequately evaluated using the unlabelled test chemical,
  - the analytical specificity and sensitivity of the method used with non-radioactive test chemical is equal to or greater than that which could be obtained with the radiolabelled test chemical,

then a radiolabelled test chemical does not need to be used. Furthermore, other radioactive and stable isotopes may be used, particularly if the element is responsible for or is a part of the toxic portion of the test chemical. If possible, the radiolabel should be located in a core portion of the molecule which is metabolically stable (it is not exchangeable, is not removed metabolically as  $\text{CO}_2$ , and does not become part of the one-carbon pool of the organism). Labelling of multiple sites or specific regions of the molecule may be necessary to follow the metabolic fate of the test chemical.

19. The radiolabelled and non-radiolabelled test chemicals should be analysed using appropriate methods to establish purity and identity. The radio-purity of the radioactive test chemical should be the highest attainable for a particular test chemical (ideally it should be greater than 95 %) and reasonable effort should be made to identify impurities present at or above 2 %. The purity, along with the identity and proportion of any impurities which have been identified, should be reported. Individual regulatory programmes may choose to provide additional guidance to assist in the definition and specifications of test chemicals composed of mixtures and methods for determination of purity.

### Dose Selection

#### *Pilot Study*

20. Usually a single oral dose is sufficient for the pilot study. The dose should be non-toxic, but high enough to allow for metabolite identification in excreta (and plasma, if appropriate) as well as to meet the stated purpose of the pilot study as noted in paragraph 12 of this Test Method.

#### *Main Studies*

21. For the main studies, a minimum of two doses is preferred since information gathered from at least two dose groups may aid in dose setting in other toxicity studies, and help in the dose-response assessment of already available toxicity tests.
22. Where two doses are administered, both doses should be high enough to allow for metabolite identification in excreta (and plasma, if appropriate). Information from available toxicity data should be considered for dose selection. If information is not available (e.g. from acute oral toxicity studies recording clinical signs of toxicity, or from repeated dose toxicity studies) a value for the higher dose that is below the  $\text{LD}_{50}$  (oral and dermal routes) or  $\text{LC}_{50}$  (inhalation route) estimate or below the lower value of the acute toxicity range estimate may be considered. The lower dose should be some fraction of the higher dose.
23. If only one dose level is investigated, ideally the dose should be high enough to allow for metabolite identification in excreta (and plasma, if appropriate), while not producing apparent toxicity. A rationale should be provided as to why no second dose level has been included.
24. If the effect of dose on kinetic processes needs to be established, two doses may not be sufficient and at least one dose should be high enough so as to saturate these processes. If the area under the plasma concentration-time curve (AUC) is not linear between two dose levels used in the main study, this is a strong indication that saturation of one or more of the kinetic processes is occurring somewhere between the two dose levels.
25. For test chemicals of low toxicity, a maximum dose of 1 000 mg/kg body weight (oral and dermal routes) should be used (if administration is by the inhalation route, refer to Chapter B.2 of this Annex for guidance; typically this dose would not exceed 2 mg/l). Chemical-specific considerations may necessitate a higher dose depending on regulatory needs. Dose selection should always be justified.

26. Single dose toxicokinetic and tissue distribution data may be adequate to determine the potential for accumulation and/or persistence. However in some circumstances repeated dose administration may be needed (i) to address more fully the potential for accumulation and/or persistence or changes in TK (i.e. for instance, enzyme induction and inhibition), or (ii) as required by the applicable regulatory system. In studies involving repeated dosing, while repeated low dose administration is usually sufficient, under certain circumstances repeated high dose administration may also be necessary (see also paragraph 57).

#### **Administration of Test Chemical**

27. The test chemical should be dissolved or suspended homogeneously in the same vehicle employed for the other oral gavage toxicity studies performed with the test chemical, if such vehicle information is available. Rationale for the choice of vehicle should be provided. The choice of the vehicle and the volume of dosing should be considered in the design of the study. The customary method of administration is by gavage; however, administration by gelatine capsule or as a dietary mixture may be advantageous in specific situations (in both cases, justification should be given). Verification of the actual dose administered to each animal should be provided.
28. The maximum volume of liquid to be administered by oral gavage at one time depends on the size of the test animals, the type of dose vehicle, and whether or not feed is withheld prior to administration of the test chemical. The rationale for administering or restricting food prior to dosing should be provided. Normally the volume should be kept as low as practical for either aqueous or non-aqueous vehicles. Dose volumes should not normally exceed 10 ml/kg body weight for rodents. Volumes of vehicles used for more lipophilic test chemicals might start at 4 ml/kg body weight. For repeated dosing, when daily fasting would be contraindicated, lower dose volumes (e.g. 2-4 ml/kg body weight) should be considered. Where possible, consideration may be given to the use of a dose volume consistent with that administered in other oral gavage studies for a test chemical.
29. Intravenous (IV) administration of the test chemical and measurement of the test chemical in blood and/or excreta may be used to establish bioavailability or relative oral absorption. For the IV study, a single dose (usually equivalent to but not to exceed the lower oral dose – see dose selection) of test chemical is administered using an appropriate vehicle. This material should be administered in a suitable volume (e.g. 1 ml/kg bw) at the chosen site of administration to at least four animals of the appropriate sex (both sexes might be used, if warranted, see paragraph 16). A fully dissolved or suspended dose preparation is necessary for IV administration of the test chemical. The vehicle for IV administration should not interfere with blood integrity or blood flow. If the test chemical is infused, the infusion rate should be reported and standardised between animals, provided an infusion pump is used. Anaesthesia should be used if one cannulates the jugular vein (for administration of test chemical and/or collection of blood) or if one uses the femoral artery for administration. Due consideration should be given to the type of anaesthesia as it may have effects on toxicokinetics. Animals should be allowed to recover adequately before administration of the test chemical plus the vehicle.
30. Other routes of administration, such as dermal and inhalation, (see paragraphs 74-78) may be applicable for certain test chemicals, considering their physico-chemical properties and the expected human use or exposure.

#### **Measurements**

##### *Mass Balance*

31. Mass balance is determined by summation of the percent of the administered (radioactive) dose excreted in urine, faeces, and expired air, and the percent present in tissues, residual carcass, and cage wash (see paragraph 46). Generally, total recoveries of administered test chemical (radioactivity) in the order of > 90 % are considered to be adequate.

##### *Absorption*

32. An initial estimation of absorption can be achieved by excluding the percentage of dose in the gastro-intestinal (GI) tract and/or faeces from the mass balance determination. For the calculation of percent absorption, see paragraph 33. For investigation of excreta, see paragraphs 44-49. If the exact extent of absorption following oral dosing cannot be established from mass balance studies (e.g. where greater than 20 % of the administered dose is present in faeces), further investigations might be necessary. These studies could comprise either 1) oral administration of test chemical and measurement of test chemical in bile or 2) oral and IV administration of test chemical and measurement of net test chemical present in urine plus expired air plus carcass by each of the two routes. In either study design, measurement of radioactivity is conducted as a surrogate method for chemical-specific analysis of test chemical plus metabolites.
33. If a biliary excretion study is undertaken, the oral route of administration is typically used. In this study, the bile ducts of at least four animals of the appropriate sex (or of both sexes, if warranted) should be cannulated and a single dose of the test chemical should be administered. Following administration of the test chemical, excretion of radioactivity/test chemical in bile should be monitored as long as necessary to estimate the percentage of the administered dose that is excreted via this route, which can be used to directly calculate the extent of oral absorption, as follows:

$$\text{Percent absorption} = (\text{amount in bile} + \text{urine} + \text{expired air} + \text{carcass without GI tract contents}) / \text{amount administered} \times 100$$

34. With some classes of test chemical, direct secretion of the absorbed dose can occur across intestinal membranes. In such cases the measurement of % dose in faeces following an oral dose in the bile duct cannulated rat is not considered to be representative of the unabsorbed dose. It is recommended that where intestinal secretion is thought to occur then the % dose absorbed be based on the absorption calculated from a comparison of the excretion following the oral versus IV route (intact or bile duct cannulated rat) (see paragraph 35). It is also recommended that where quantification of the intestinal secretion is considered necessary, excretion in the bile duct cannulated rat following IV dose administration be measured.

#### *Bioavailability*

35. Bioavailability can be determined from plasma/blood kinetics of the oral and IV groups, as described in paragraphs 50-52, by specific chemical analysis of the test chemical and/or relevant metabolite(s), therefore not requiring radiolabelled test chemical. The calculation of bioavailability (F) of the test chemical or relevant metabolite(s) can then be made as follows:

$$F = (AUC_{\text{exp}}/AUC_{\text{IV}}) \times (\text{Dose}_{\text{IV}}/\text{Dose}_{\text{exp}})$$

where AUC is the area under the plasma concentration-time curve, and exp is the experimental route (oral, dermal or via inhalation).

36. For use in risk assessment of systemic effects, bioavailability of the toxic component is in general preferred over the percent absorption when comparing systemic concentrations from animal studies with analogous biomonitoring data from worker exposure studies. The situation may become more complex if doses are in the non-linear range so it is important that toxicokinetic screening determines doses in the linear range.

#### *Tissue Distribution*

37. Knowledge of tissue distribution of a test chemical and/or its metabolites is important for the identification of target tissues, and understanding of the underlying mechanisms of toxicity, and in order to get information on the potential for test chemical and metabolite accumulation and persistence. The percent of the total (radioactive) dose in tissues as well as residual carcass should at a minimum be measured at the termination of the excretion experiment (e.g. typically up to 7 days post dose or less depending on test chemical specific behaviour). When no test chemical is detected in tissues at study termination (e.g. because the test chemical might have been eliminated before study termination due to a short half-life), care should be taken in order to prevent misinterpretation of the data. In this type of situation, tissue distribution should be investigated at the time of test chemical (and/or metabolite) peak plasma/blood concentration ( $T_{\text{max}}$ ) or peak rate of urinary excretion, as appropriate (see paragraph 38). Furthermore, tissue collection at additional time points may be needed to determine tissue distribution of the test chemical and/or its metabolites, to evaluate time dependency (if appropriate), to aid in establishing mass balance, and/or as required by a competent authority. Tissues that should be collected include liver, fat, GI tract, kidney, spleen, whole blood, residual carcass, target organ tissues and any other tissues (e.g. thyroid, erythrocytes, reproductive organs, skin, eye (particularly in pigmented animals) of potential significance in the toxicological evaluation of the test chemical. Analysis of additional tissues at the same time points should be considered to maximise utilisation of animals and in the event that target organ toxicity is observed in sub-chronic or chronic toxicity studies. The (radioactive) residue concentration and tissue-to-plasma (blood) ratios should also be reported.
38. The evaluation of tissue distribution at additional time points such as the time of peak plasma/blood concentration (e.g.  $T_{\text{max}}$ ) or the peak rate of urinary excretion, obtained from the respective plasma/blood kinetic or excretion experiments, may also be needed or required by a competent authority. This information can be useful for understanding toxicity and the potential for test chemical and metabolite accumulation and persistence. Justification for sample selection should be provided; samples for analysis generally should be the same as those above (see paragraph 37).
39. Quantification of radioactivity for tissue distribution studies can be performed using organ dissection, homogenisation, combustion and/or solubilisation, followed by liquid scintillation counting (LSC) of trapped residues. Certain techniques, currently at various stages of development, e.g. Quantitative whole-body autoradiography and receptor microscopic autoradiography, may prove useful in determining the distribution of a test chemical in organs and/or tissues (3) (4).
40. For routes of exposure other than oral, specific tissues should be collected and analysed, such as lungs in inhalation studies and skin in dermal studies. See paragraphs 74-78.

*Metabolism*

41. Excreta (and plasma, if appropriate) should be collected for identification and quantitation of unchanged test chemical and metabolites as described under paragraphs 44-49. Pooling of excreta to facilitate metabolite identification within a given dose group is acceptable. Profiling of metabolites from each time period is recommended. However, if lack of sample and/or radioactivity precludes this, pooling of urine and faeces across several time points is acceptable but pooling across sexes or doses is not acceptable. Appropriate qualitative and quantitative methods should be used to assay urine, faeces, expired radioactivity from treated animals, and bile if appropriate.
42. Reasonable efforts should be made to identify all metabolites present at 5 % or greater of the administered dose and to provide a metabolic scheme for the test chemical. Test chemicals which have been characterised in excreta as comprising 5 % or greater of the administered dose should be identified. Identification refers to the exact structural determination of components. Typically, identification is accomplished either by co-chromatography of the metabolite with known standards using two dissimilar systems or by techniques capable of positive structural identification such as mass spectrometry, nuclear magnetic resonance (NMR), etc. In the case of co-chromatography, chromatographic techniques utilising the same stationary phase with two different solvent systems are not considered to be an adequate two-method verification of metabolite identity, since the methods are not independent. Identification by co-chromatography should be obtained using two dissimilar, analytically independent systems such as reverse and normal phase thin layer chromatography (TLC) and high performance liquid chromatography (HPLC). Provided that the chromatographic separation is of suitable quality, then additional confirmation by spectroscopic means is not necessary. Alternatively, unambiguous identification can also be obtained using methods providing structural information such as: liquid chromatography/mass spectrometry (LC-MS), or liquid chromatography/tandem mass spectrometry (LC-MS/MS), gas chromatography/mass spectrometry (GC-MS), and NMR spectrometry.
43. If identification of metabolites at 5 % or greater of the administered dose is not possible, a justification/explanation should be provided in the final report. It might be appropriate to identify metabolites representing less than 5 % of the administered dose to gain a better understanding of the metabolic pathway for hazard and/or risk assessment of the test chemical. Structural confirmation should be provided whenever possible. This may include profiling in plasma or blood or other tissues.

*Excretion*

44. The rate and extent of excretion of the administered dose should be determined by measuring the percent recovered (radioactive) dose from urine, faeces and expired air. These data will also assist in establishing mass balance. The quantities of test chemical (radioactivity) eliminated in the urine, faeces, and expired air should be determined at appropriate time intervals (see paragraphs 47-49). Repeated dose experiments should be properly designed to allow for collection of excretion data to meet the objectives described in the paragraph 26. This will allow for comparison to single dose experiments.
45. If a pilot study has shown that no significant amount of test chemical (radioactivity) (according to paragraph 49) is excreted in expired air, then expired air does not need to be collected in the definitive study.
46. Each animal is to be placed in a separate metabolic unit for collection of excreta (urine, faeces and expired air). At the end of each collection period (see paragraphs 47-49), the metabolic units should be rinsed with appropriate solvent (this is known as the "cage wash") to ensure maximum recovery of the test chemical (radioactivity). Collection of excreta should be terminated at 7 days, or after at least 90 % of the administered dose has been recovered, whichever occurs first.
47. The total quantities of test chemical (radioactivity) in urine are to be determined for at least two time points on day 1 of collection, one of which should be at 24 h post dosing, and daily thereafter until study termination. The selection of more than two sampling points on day one (e.g. at 6, 12 and 24 h) is encouraged. The results of pilot studies should be analysed for information on alternate or additional time points for collection. A rationale should be provided for the collection schedules.
48. The total quantities of test chemical (radioactivity) in faeces should be determined on a daily basis beginning at 24 h post-dosing until study termination, unless pilot studies suggest alternate or additional time points for collection. A rationale should be provided for alternative collection schedules.
49. The collection of expired CO<sub>2</sub> and other volatile materials may be discontinued in a given study experiment when less than 1 % of the administered dose is found in the exhaled air during a 24-h collection period.

### Time Course Studies

#### *Plasma/Blood Kinetics*

50. The purpose of these studies is to obtain estimates of basic TK parameters [e.g.  $C_{max}$ ,  $T_{max}$ , half-life ( $t_{1/2}$ ), AUC] for the test chemical. These studies may be conducted at one dose or, more likely, at two or more doses. Dose setting should be determined by the nature of the experiment and/or the issue being addressed. Kinetic data may be needed to resolve issues such as test chemical bioavailability and/or to clarify the effect of dose on clearance (e.g. to clarify whether clearance is saturated in a dose-dependent fashion).
51. For these studies a minimum of four animals of one sex per dose group should be used. Justification should be provided for the sex of the animals used. The use of both sexes (four males and four females) should be considered if there is evidence to support significant sex-related differences in toxicity.
52. Following administration of the test chemical (radiolabelled), blood samples should be obtained from each animal at suitable time points using appropriate sampling methodology. The volume and number of blood samples which can be obtained per animal might be limited by potential effects of repeated sampling on animal health/physiology and/or the sensitivity of the analytical method. Samples should be analysed for each individual animal. In some circumstances (e.g. metabolite characterisation), it might be necessary to pool samples from more than one animal. Pooled samples should be clearly identified and an explanation for pooling provided. If a radiolabelled test chemical is used, analysis of total radioactivity present might be adequate. If so, total radioactivity should be analyzed in whole blood and plasma or plasma and red blood cells to allow calculation of the blood/plasma ratio. In other circumstances, more specific investigations requiring the identification of parent compound and/or metabolites, or to assess protein binding might be necessary.

#### *Other Tissue Kinetics*

53. The purpose of these studies is to obtain time course information to address questions related to issues such as toxic mode of action, bioaccumulation and bio-persistence via determination of levels of test chemical in various tissues. The selection of tissues and the number of time points evaluated will depend on the issue to be addressed and the toxicological database for the test chemical. The design of these additional tissue kinetics studies should take into account information gathered as described in paragraphs 37-40. These studies might involve single or repeated dosing. A detailed rationale for the approach used should be provided.
54. Reasons for performing other tissue kinetic studies might include:
  - Evidence of extended blood half-life, suggesting possible accumulation of test chemical in various tissues, or
  - interest in seeing if a steady state level has been achieved in specific tissues (e.g. in repeated dosing studies, even though an apparent blood steady state level of test chemical may have been achieved, there may be interest in ascertaining that a steady state level has also been attained in target tissues).
55. For these types of time-course studies, an appropriate oral dose of test chemical should be administered to a minimum of four animals per dose per time point and the time course of distribution monitored in selected tissues. Only one sex may be used, unless gender specific toxicity is observed. Whether total radioactivity or parent chemical and/or metabolites are analysed will also depend on the issue being addressed. Assessment of tissue distribution should be made using appropriate techniques.

#### *Enzyme Induction/Inhibition*

56. Studies addressing the possible effects of enzyme induction/inhibition or biotransformation of test chemical under study may be needed under one or more of the following cases:
  - (1) Available evidence indicates a relationship between biotransformation of test chemical and enhanced toxicity;
  - (2) The available toxicity data indicate a non-linear relationship between dose and metabolism;
  - (3) The results of metabolite identification studies show identification of a potentially toxic metabolite that might have been produced by an enzyme pathway induced by the test chemical;
  - (4) In explaining effects which are postulated to be linked to enzyme induction phenomena;



(5) If toxicologically significant alterations in the metabolic profile of the test chemical are observed through either *in vitro* or *in vivo* experiments with different species or conditions, characterisation of the enzyme(s) involved may be needed (e.g. Phase I enzymes such as isoenzymes of the Cytochrome P450-dependent mono-oxygenase system, Phase II enzymes such as isoenzymes of sulfotransferase or uridine diphosphate glucuronosyl transferase, or any other relevant enzymes). This information might be used to evaluate the pertinence of species to species extrapolations.

57. Appropriate study protocols to evaluate test chemical related changes in TK, suitably validated and justified should be used. Example study designs consist of repeated dosing with unlabelled test chemical, followed by a single radiolabelled dose on day 14, or repeated dosing with radiolabelled test chemical and sampling at days 1, 7 and 14 for determination of metabolite profiles. Repeated dosing with radiolabelled test chemical may also provide information on bioaccumulation (see paragraph 26).

#### SUPPLEMENTAL APPROACHES

58. Supplemental approaches beyond the *in vivo* experiments described in this Test Method may provide useful information on the absorption, distribution, metabolism or elimination of a test chemical in certain species.

#### Use of *in vitro* information

59. Several questions concerning the metabolism of the test chemical may be addressed in *in vitro* studies using appropriate test systems. Freshly isolated or cultured hepatocytes and subcellular fractions (e.g. microsomes and cytosol or S9 fraction) from liver may be used to study possible metabolites. Local metabolism in the target organ, e.g. lung, may be of interest for risk assessment. For these purposes, microsomal fractions of target tissues may be useful. Studies with microsomes may be useful to address potential gender and life-stage differences and characterise enzyme parameters ( $K_m$  and  $V_{max}$ ) which can aid in the assessment of dose dependency of metabolism in relation to exposure levels. In addition microsomes may be useful to identify the specific microsomal enzymes involved in the metabolism of the test chemical which can be relevant in species extrapolation (see also paragraph 56). The potential for induction of biotransformation can also be examined by using liver subcellular fractions (e.g. microsomes and cytosol) of animals pre-treated with the test chemical of interest, *in vitro* via hepatocyte induction studies or from specific cell lines expressing relevant enzymes. In certain circumstances and under appropriate conditions, subcellular fractions coming from human tissues might be considered for use in determining potential species differences in biotransformation. The results from *in vitro* investigations may also have utility in the development of PBTK models (5).

60. *In vitro* dermal absorption studies may provide supplemental information to characterise absorption (6).

61. Primary cell cultures from liver cells and fresh tissue slices may be used to address similar questions as with liver microsomes. In certain cases, it may be possible to answer specific questions using cell lines with defined expression of the relevant enzyme or engineered cell lines. In certain cases, it may be useful to study the inhibition and induction of specific cytochrome P450 isozymes (e.g. CYP1A1, 2E1, 1A2, and others) and/or phase II enzymes by the parent compound using *in vitro* studies. Information obtained may have utility for similarly structured compounds.

#### Use of Toxicokinetic Data from Toxicity Studies as Complementary Information

62. Analysis of blood, tissue and/or excreta samples obtained during the conduct of any other toxicity studies can provide data on bioavailability, changes in plasma concentration in time (AUC,  $C_{max}$ ), bioaccumulation potential, clearance rates, and gender or life-stage changes in metabolism and kinetics.

63. Consideration of the study design can be used to answer questions relating to: saturation of absorption, biotransformation or excretion pathways at higher dose levels; the operation of new metabolic pathways at higher doses and the limitation of toxic metabolites to higher doses.

64. Other hazard assessment considerations could include issues such as:

— Age-related sensitivity due to differences in the status of the blood-brain barrier, the kidney and/or detoxification capacities;

— Sub-population sensitivity due to differences in biotransformation capacities or other TK differences;

— Extent of exposure of the foetus by transplacental transfer of chemicals or of the newborn through lactation.



### Use of Toxicokinetic Modelling

65. Toxicokinetic models may have utility for various aspects of hazard and risk assessment as for example in the prediction of systemic exposure and internal tissue dose. Furthermore specific questions on mode of action may be addressed, and these models can provide a basis for extrapolation across species, routes of exposure, dosing patterns, and for human risk assessment. Data useful for developing PBTK models for a test chemical in any given species include (1) partition coefficients, (2) biochemical constants and physiological parameters, (3) route-specific absorption parameters and 4) *in vivo* kinetic data for model evaluation [e.g. clearance parameters for relevant (> 10 %) excretion pathways,  $K_m$  and  $V_{max}$  for metabolism]. The experimental data used in model development should be generated with scientifically sound methods and the model results validated. Test chemical- and species-specific parameters such as absorption rates, blood-tissue partitioning and metabolic rate constants are often determined to facilitate development of non-compartmental or physiologically-based models (7).

### DATA AND REPORTING

66. It is recommended that the study report include a table of contents.

### Body of the Report

67. The body of the report should include information covered by this Test Method organised into sections and paragraphs as follows:

#### *Summary*

68. This section of the study report should include a summary of the study design and a description of methods used. It should also highlight the key findings regarding mass balance, the nature and magnitude of metabolites, tissue residue, rate of clearance, bioaccumulation potential, sex differences, etc. The summary should be presented in sufficient detail to permit evaluation of the findings.

#### *Introduction*

69. This section of the report should include the study objectives, rationale and design, as well as, appropriate references and any background history.

#### *Materials and Methods*

70. This section of the report should include detailed descriptions of all pertinent information including:

##### (a) Test Chemical

This subsection should include identification of the test chemical: chemical name, molecular structure, qualitative and quantitative determination of its chemical composition, chemical purity and whenever possible, type and quantities of any impurities. It should also include information on physical/chemical properties including physical state, colour, gross solubility and/or partition coefficient, stability, and if appropriate, corrosivity. If applicable, information on isomers should be provided. If the test chemical is radiolabelled, information on the following should be included in this subsection: the type of radionuclide, position of label, specific activity, and radiochemical purity.

The type or description of any vehicle, diluents, suspending agents, and emulsifiers or other materials used in administering the test chemical should be stated.

##### (b) Test Animals

This subsection should include information on the test animals, including selection and justification for species, strain, and age at study initiation, sex as well as body weight, health status, and animal husbandry.

##### (c) Methods

This subsection should include details of the study design and methodology used. It should include a description of:

- (1) Justification for any modification of route of exposure and exposure conditions, if applicable;

- (2) Justification for selection of dose levels;
  - (3) Description of pilot studies used in the experimental design of the follow-up studies, if applicable. Pilot study supporting data should be submitted;
  - (4) How the dosing solution was prepared and the type of solvent or vehicle, if any, used;
  - (5) Number of treatment groups and number of animals per group;
  - (6) Dosage levels and volume (and specific activity of the dose when radioactivity is used);
  - (7) Route(s) and methods of administration;
  - (8) Frequency of dosing;
  - (9) Fasting period (if used);
  - (10) Total radioactivity per animal;
  - (11) Animal handling;
  - (12) Sample collection and handling;
  - (13) Analytical methods used for separation, quantitation and identification of metabolites;
  - (14) Limit of detection for the employed methods;
  - (15) Other experimental measurements and procedures employed (including validation of methods for metabolite analysis).
- (d) Statistical Analysis

If statistical analysis is used to analyse the study findings, then sufficient information on the method of analysis and the computer program employed should be included, so that an independent reviewer/statistician can re-evaluate and reconstruct the analysis.

In the case of systems modelling studies such as PBTK, presentation of models should include a full description of the model to allow independent reconstruction and validation of the model (see paragraph 65 and Appendix: Definitions).

#### *Results*

71. All data should be summarised and tabulated with appropriate statistical evaluation and described in the text of this section. Radioactivity counting data should be summarised and presented as appropriate for the study, typically as microgram or milligram equivalents per mass of sample, although other units may be used. This section should include graphic illustrations of the findings, reproduction of representative chromatographic and spectrometric data, metabolite identification/quantification and proposed metabolic pathways including molecular structure of metabolites. In addition the following information is to be included in this section, if applicable:

- (1) Quantity and percent recovery of radioactivity in urine, faeces, expired air, and urine and faeces cage wash.
  - For dermal studies, also include data on test chemical recovery from treated skin, skin washes, and residual radioactivity in the skin covering apparatus and metabolic unit as well as results of the dermal washing study. For further discussion, see paragraphs 74-77.
  - For inhalation studies, also include data on recovery of test chemical from lungs and nasal tissues (8). For further discussion, see paragraph 78.

- (2) Tissue distribution reported as percent of administered dose and concentration (microgram equivalents per gram of tissue), and tissue-to-blood or tissue-to-plasma ratios;
- (3) Material balance developed from each study involving the assay of body tissues and excreta;
- (4) Plasma concentrations and toxicokinetic parameters (bioavailability, AUC, C<sub>max</sub>, T<sub>max</sub>, clearance, half-life) after administration by the relevant route(s) of exposure;
- (5) Rate and extent of absorption of the test chemical after administration by the relevant route(s) of exposure;
- (6) Quantities of the test chemical and metabolites (reported as percent of the administered dose) collected in excreta;
- (7) Reference to appendix data which contain individual animal data for all measurement endpoints (e.g. dose administration, percent recovery, concentrations, TK parameters, etc.);
- (8) A figure with the proposed metabolic pathways and the molecular structures of the metabolites.

#### *Discussion and Conclusions*

72. In this section the author(s) should:

- (1) Provide a proposed metabolic pathway based on the results of the metabolism and disposition of the test chemical;
- (2) Discuss any potential species and sex differences regarding the disposition and/or biotransformation of the test chemical;
- (3) Tabulate and discuss the identification and magnitude of metabolites, rates of clearance, bioaccumulation potential, and level of tissue residues of parent, and/or metabolite(s), as well as possible dose-dependent changes in TK parameters, as appropriate;
- (4) Integrate into this section any relevant TK data obtained in the course of conducting toxicity studies;
- (5) Provide a concise conclusion that can be supported by the findings of the study;
- (6) Add Sections (as needed or appropriate).

73. Additional sections should be used to include supporting bibliographic information, tables, figures, appendices, etc.

#### ALTERNATIVE ROUTES OF EXPOSURE

##### **Dermal**

##### *Dermal Treatment*

74. This section provides specific information on the investigation of the toxicokinetics of the test chemical by the dermal route. For dermal absorption, chapter B.44 of this Annex [Skin absorption: *in vivo* method (9)] should be consulted. For other endpoints such as distribution and metabolism, this Test Method B.36 can be used. One or more dose levels for the test chemical should be used in the dermal treatment. The test chemical (e.g. neat, diluted or formulated material containing the test chemical which is applied to the skin) should be the same (or a realistic surrogate) as that to which humans or other potential target species might be exposed. The dose level(s) should be selected in accordance with paragraphs 20-26 of this Test Method. Factors that could be taken into consideration in dermal dose selection include expected human exposure and/or doses at which toxicity was observed in other dermal toxicity studies. The dermal dose(s) should be dissolved, if necessary, in a suitable vehicle and applied in a volume adequate to deliver the doses. Shortly before testing, fur should be clipped from the dorsal area of the trunk of the test animals. Shaving may be employed, but it should be carried out approximately 24 h before the test. When clipping or shaving the fur, care should be taken to avoid

abrading the skin, which could alter its permeability. Approximately 10 % of the body surface should be cleared for application of the test chemical. With highly toxic chemicals, the surface area covered may be less than approximately 10 %, but as much of the area as possible is to be covered with a thin and uniform film. The same treatment surface area should be used for all dermal test groups. The dosed areas are to be protected with a suitable covering which is secured in place. The animals should be housed separately.

75. A dermal washing study should be conducted to assess the amount of the applied dose of the test chemical that may be removed from the skin by washing the treated skin area with a mild soap and water. This study can also aid in establishing mass balance when the test chemical is administered by the dermal route. For this dermal washing study, a single dose of the test chemical should be applied to two animals. Dose level selection is in accordance with paragraph 23 of this Test Method (also see paragraph 76 for discussion of skin contact time). The amounts of test chemical recovered in the washes should be determined to assess the effectiveness of removal of the test chemical by the washing procedure.
76. Unless precluded by corrosiveness, the test chemical should be applied and kept on the skin for a minimum of 6 h. At the time of removal of the covering, the treated area should be washed following the procedure as outlined in the dermal washing study (see paragraph 75). Both covering and the washes should be analysed for residual test chemical. At the termination of the studies, each animal should be humanely killed in accordance with (2), and the treated skin removed. An appropriate section of treated skin should be analysed to determine residual test chemical (radioactivity).
77. For the toxicokinetic assessment of pharmaceuticals, different procedures, in accordance with the appropriate regulatory system, may be needed.

#### **Inhalation**

78. A single concentration (or more if needed) of test chemical should be used. The concentration(s) should be selected in accordance with paragraphs 20-26 of this Test Method. Inhalation treatments are to be conducted using a "nose-cone" or "head-only" apparatus to prevent absorption by alternate routes of exposure (8). If other inhalation exposure conditions are used, justification for the modification should be documented. The duration of exposure by inhalation should be defined; a typical exposure is 4-6 h.

#### **LITERATURE:**

- (1) OECD (2009). Preliminary Review of OECD Test Guidelines for their Applicability to Manufactured Nanomaterials, Series on the Safety of Manufactured Nanomaterials No 15, ENV/JM/MONO(2009)21, OECD, Paris.
- (2) OECD (2000). Guidance Document on Recognition, Assessment and Use of Clinical Signs as Humane Endpoints for Experimental Animals Used in Safety Evaluation; Environmental Health and Safety Publications, Series on Testing and Assessment No 19, ENV/JM/MONO(2000), OECD, Paris.
- (3) Solon E G, Kraus L (2002). Quantitative whole-body autoradiography in the pharmaceutical industry; Survey results on study design, methods, and regulatory compliance, *J Pharm and Tox Methods* 46: 73-81.
- (4) Stumpf WE (2005). Drug localization and targeting with receptor microscopic autoradiography. *J. Pharmacological and Toxicological Methods* 51: 25-40.
- (5) Loizou G, Spendiff M, Barton HA, Bessems J, Bois FY, d'Yvoire MB, Buist H, Clewell HJ 3rd, Meek B, Gundert-Remy U, Goerlitz G, Schmitt W. (2008). Development of good modelling practice for physiologically based pharmacokinetic models for use in risk assessment: The first steps. *Regulatory Toxicology and Pharmacology* 50: 400 – 411.
- (6) Chapter B.45 of this Annex, Skin Absorption: In Vitro Method.
- (7) IPCS (2010). Characterization and application of Physiologically-Based Pharmacokinetic Models in Risk Assessment. IPCS Harmonization Project Document No 9. Geneva, World Health Organization, International Programme on Chemical Safety.
- (8) OECD (2009). Guidance Document on Acute Inhalation Toxicity Testing, Series on Testing and Assessment No 39, ENV/JM/MONO(2009)28, OECD, Paris.

- 
- (9) Chapter B.44 of this Annex, Skin Absorption: In Vivo Method.
- (10) Barton HA, *et al.* (2006). The Acquisition and Application of Absorption, Distribution, Metabolism, and Excretion (ADME) Data in Agricultural Chemical Safety Assessments, *Critical Reviews in Toxicology* 36: 9-35.
- (11) Gibaldi M and Perrier D, (1982), *Pharmacokinetics*, 2nd edition, Marcel Dekker, Inc., New York.
-

## Appendix

## DEFINITIONS

**Absorption:** Process(es) of uptake of chemicals into or across tissues. Absorption refers to parent compound and all its metabolites. Not to be confused with "bioavailability".

**Accumulation (Bioaccumulation):** Increase of the amount of a test chemical over time within tissues (usually fatty tissues, following repeated exposure); if the input of a test chemical into the body is greater than the rate at which it is eliminated, the organism accumulates the test chemical and toxic concentrations of a test chemical might be achieved.

**ADME:** Acronym for "Absorption, Distribution, Metabolism, and Excretion".

**AUC:** (Area under the plasma concentration-time curve): Area under the curve in a plot of concentration of test chemical in plasma over time. It represents the total amount of test chemical absorbed by the body within a predetermined period of time. Under linear conditions, the AUC (from time zero to infinity) is proportional to the total amount of a test chemical absorbed by the body, irrespective of the rate of absorption.

**Autoradiography:** (Whole-body autoradiography): Used to determine qualitatively and/or quantitatively the tissue localisation of a radioactive test chemical, this technique uses X-ray film or more recently digital phosphorimaging to visualize radioactively labelled molecules or fragments of molecules by recording the radiation emitted within the object under study. Quantitative whole-body autoradiography, compared to organ dissection, may have some advantages for the evaluation of test chemical distribution and the assessment of overall recovery and resolution of radioactive material in tissues. One significant advantage, for example, is it can be used in a pigmented animal model to assess possible association of the test chemical with melanin, which can bind certain molecules. However, while it may provide convenient whole body overviews of the high-capacity-low-affinity binding sites, this technique might be limited in recognising specific target sites such as receptor-binding sites where relatively high-resolution and high-sensitivity are needed for detection. When autoradiography is used, experiments intended to determine mass balance of administered compound should be conducted as a separate group or in a separate study from the tissue distribution experiment, where all excreta (which may also include expired air) and whole carcasses are homogenised and assayed by liquid scintillation counting.

**Biliary excretion:** Excretion via the bile ducts.

**Bioaccumulation:** See "Accumulation".

**Bioavailability:** Fraction of an administered dose that reaches the systemic circulation or is made available at the site of physiological activity. Usually, bioavailability of a test chemical refers to the parent compound, but it could refer to its metabolite. It considers only one chemical form. *Nota Bene:* bioavailability and absorption are not the same. The difference between e.g. oral absorption (i.e. presence in gut wall and portal circulation) and bioavailability (i.e. presence in systemic blood and in tissues) can arise from chemical degradation due to gut wall metabolism or efflux transport back to the intestinal lumen or presystemic metabolism in the liver, among other factors (10). Bioavailability of the toxic component (parent compound or a metabolite) is a critical parameter in human risk assessment (high-to-low dose extrapolation, route-to-route extrapolation) for derivation of an internal value from the external NOAEL or BMD (applied dose). For liver effects upon oral administration, it is the oral absorption that suffices. However, for every effect other than at the portal of entry, it is the bioavailability that is in general a more reliable parameter for further use in risk assessment, not the absorption.

**Biopersistence:** See "Persistence".

**Biotransformation:** (Usually enzymatic) chemical conversion of a test chemical of interest into a different chemical within the body. Synonymous with "metabolism".

**C<sub>max</sub>:** Either maximal (peak) concentration in blood (plasma/serum) after administration or maximal (peak) excretion (in urine or faeces) after administration.

**Clearance rate:** Quantitative measure of the rate at which a test chemical is removed from the blood, plasma or a certain tissue per unit time.

**Compartment:** Structural or biochemical portion (or unit) of a body, tissue or cell, that is separate from the rest.

**Detoxification pathways:** Series of steps leading to the elimination of toxic chemicals from the body, either by metabolic change or excretion.

**Distribution:** Dispersal of a test chemical and its derivatives throughout an organism.

**Enzymes/Isozymes:** Proteins that catalyse chemical reactions. Isozymes are enzymes that catalyse similar chemical reactions but differ in their amino acid sequence.

**Enzymatic Parameters:**  $K_m$ : Michaelis constant and  $V_{max}$ : maximum velocity.

**Excretion:** Process(es) by which an administered test chemical and/or its metabolites are removed from the body.

**Exogenously:** Introduced from or produced outside the organism or system.

**Extrapolation:** Inference of one or more unknown values on the basis of that which is known or has been observed.

**Half-life ( $t_{1/2}$ ):** The time taken for the concentration of the test chemical to decrease by one-half in a compartment. It typically refers to plasma concentration or the amount of the test chemical in the whole body.

**Induction/Enzyme induction:** Enzyme synthesis in response to an environmental stimulus or inducer molecule.

**Linearity/linear kinetics:** A process is linear in terms of kinetics when all transfer rates between compartments are proportional to the amounts or concentrations present, i.e. first order. Consequently, clearance and distribution volumes are constant, as well as half-lives. The concentrations achieved are proportional to the dosing rate (exposure), and accumulation is more easily predictable. Linearity/Non-linearity can be assessed by comparing the relevant parameters, e.g. AUC, after different doses or after single and repeated exposure. Lack of dose dependency may be indicative of saturation of enzymes involved in the metabolism of the compound, an increase of AUC after repeated exposure as compared to single exposure may be an indication for inhibition of metabolism and a decrease in AUC may be an indication for induction of metabolism [see also (11)].

**Mass balance:** Accounting of test chemical entering and leaving the system.

**Material balance:** See "mass balance".

**Mechanism (Mode) of toxicity/Mechanism (Mode) of action:** Mechanism of action refers to specific biochemical interactions through which a test chemical produces its effect. Mode of action refers to more general pathways leading to the toxicity of a test chemical.

**Metabolism:** Synonymous with "biotransformation".

**Metabolites:** Products of metabolism or metabolic processes.

**Oral Absorption:** The percentage of the dose of test chemical absorbed from the site of administration (i.e. GI tract). This critical parameter can be used to understand the fraction of the administered test chemical that reaches the portal vein, and subsequently the liver.

**Partition coefficient:** Also known as the distribution coefficient, it is a measure of the differential solubility of a chemical in two solvents.

**Peak blood (plasma/serum) levels:** Maximal (peak) blood (plasma/serum) concentration after administration (see also " $C_{max}$ ").

**Persistence (biopersistence):** Long-term presence of a chemical (in a biological system) due to resistance to degradation/elimination.

**Read-across:** The endpoint information for one or more chemicals is used to make a prediction of the endpoint for the target chemical.

**Receptor Microscopic Autoradiography** (or Receptor Microautoradiography): This technique may be used to probe xenobiotic interaction with specific tissue sites or cell populations as for instance in receptor binding or specific mode of action studies that may require high-resolution and high sensitivity which may not be feasible with other techniques such as whole-body autoradiography.

**Route of administration** (oral, IV, dermal, inhalation, etc.): Refers to the means by which chemicals are administered to the body (e.g. orally by gavage, orally by diet, dermal, by inhalation, intravenously, etc.).



**Saturation:** State whereby one or more of the kinetic (e.g. absorption, metabolism or clearance) process(es) are at a maximum (read "saturated").

**Sensitivity:** Capability of a method or instrument to discriminate between measurement responses representing different levels of a variable of interest.

**Steady-state blood (plasma) levels:** Non-equilibrium state of an open system in which all forces acting on the system are exactly counter-balanced by opposing forces, in such a manner that all its components are stationary in concentration although matter is flowing through the system.

**Systems Modelling** (Physiologically-based Toxicokinetic, Pharmacokinetic-based, Physiologically-based Pharmacokinetic, Biologically-based, etc.): Abstract model that uses mathematical language to describe the behaviour of a system.

**Target tissue:** Tissue in which a principal adverse effect of a toxicant is manifested.

**Test chemical:** Any chemical or mixture tested using this Test Method.

**Tissue distribution:** Reversible movement of a test chemical from one location in the body to another. Tissue distribution can be studied by organ dissection, homogenisation, combustion and liquid scintillation counting or by qualitative and/or quantitative whole body autoradiography. The former is useful to obtain concentration and percent of recovery from tissues and remaining carcass of the same animals, but may lack resolution for all tissues and may have less than ideal overall recovery (< 90 %). See definition for the latter above.

**T<sub>max</sub>:** Time to reach C<sub>max</sub>.

**Toxicokinetics** (Pharmacokinetics): Study of the absorption, distribution, metabolism, and excretion of chemicals over time.

**Validation of models:** Process of assessing the adequacy of a model to consistently describe the available toxicokinetic data. Models may be evaluated via statistical and visual comparison of model predictions with experimental values against a common independent variable (e.g. time). The extent of evaluation should be justified in relation to the intended use of the model.'

(8) Chapter B.52 is added:

## B.52. ACUTE INHALATION TOXICITY — ACUTE TOXIC CLASS METHOD

### INTRODUCTION

1. This Test Method is equivalent to OECD Test Guideline (TG) 436 (2009). The first acute inhalation TG 403 was adopted in 1981, and has since been revised (see chapter B.2 of this Annex (1)). Development of an Inhalation Acute Toxic Class (ATC) method (2) (3) (4) was considered appropriate following the adoption of the revised oral ATC method (chapter B.1 tris of this Annex) (5). A retrospective performance assessment of the ATC test method for acute inhalation toxicity showed that the method is suitable for being used for Classification and Labelling purposes (6). The inhalation ATC Test Method will allow the use of serial steps of fixed target concentrations to provide a ranking of test chemical toxicity. Lethality is used as key endpoint, however, animals in severe pain or distress, suffering or impending death should be humanely killed to minimise suffering. Guidance on humane endpoints is available in the OECD Guidance Document No 19 (7).
2. Guidance on the conduct and interpretation of this Test Method can be found in the Guidance Document No 39 on Acute Inhalation Toxicity Testing (GD 39) (8).
3. Definitions used in the context of this Test Method are provided in Appendix 1 and in GD 39 (8).
4. The Test Method provides information on the hazardous properties and allows the test chemical to be ranked and classified according to the Regulation (EC) No 1272/2008 for the classification of chemicals that cause acute toxicity (9). In case point estimates of LC<sub>50</sub>-values or concentration-response analyses are required, chapter B.2 of this Annex (1) is the appropriate Test Method to use. Further guidance on Test Method selection can be found in GD 39 (8). This Test Method is not specially intended for the testing of specialized materials, such as poorly soluble isometric or fibrous materials or manufactured nanomaterials.

#### INITIAL CONSIDERATIONS

5. Before considering testing in accordance with this Test Method, all available information on the test chemical, including existing studies whose data would support not doing additional testing should be considered by the testing laboratory in order to minimize animal usage. Information that may assist in the selection of the most appropriate species, strain, sex, mode of exposure and appropriate test concentrations include the identity, chemical structure, and physico-chemical properties of the test chemical; results of any *in vitro* or *in vivo* toxicity tests; anticipated use(s) and potential for human exposure; available (Q)SAR data and toxicological data on structurally related chemicals. Concentrations that are expected to cause severe pain and distress, due to corrosive<sup>(1)</sup> or severely irritant actions, should not be tested with this Test Method [see GD 39 (8)].

#### PRINCIPLE OF THE TEST

6. It is the principle of the test that based on a stepwise procedure, sufficient information is obtained on the acute inhalation toxicity of the test chemical during an exposure period of 4 hours to enable its classification. Other durations of exposure may apply to serve specific regulatory purposes. At any of the defined concentration steps, 3 animals of each sex are tested. Depending on the mortality and/or the moribund status of the animals, 2 steps may be sufficient to allow judgement on the acute toxicity of the test chemical. If evidence is provided that one sex is more susceptible than the other, then the test may be continued with the more susceptible sex only. The outcome of the previous step will determine the following step such that:
  - a) No further testing is needed,
  - b) Testing of three animals per sex, or
  - c) Testing with 6 animals of the more susceptible sex only *i.e.* the lower boundary estimates of the toxic class should be based on 6 animals per test concentration group, regardless of sex.
7. Moribund animals or animals obviously in pain or showing signs of severe and enduring distress should be humanely killed, and are considered in the interpretation of the test results in the same way as animals that died on test. Criteria for making the decision to kill moribund or severely suffering animals, and guidance on the recognition of predictable or impending death, are the subject of Guidance Document No 19 on Humane Endpoints (7).

#### DESCRIPTION OF THE METHOD

##### **Selection of animal species**

8. Healthy young adult animals of commonly used laboratory strains should be used. The preferred species is the rat and justifications should be provided if other species are used.

##### **Preparation of animals**

9. Females should be nulliparous and non-pregnant. On the exposure day, animals should be young adults 8 to 12 weeks of age, and body weights should be within  $\pm 20\%$  of the mean weight for each sex of any previously exposed animals at the same age. The animals are randomly selected, marked for individual identification. The animals are kept in their cages for at least 5 days prior to the start of the test to allow for acclimatisation to laboratory conditions. Animals should also be acclimatised to the test apparatus for a short period prior to testing, as this will lessen the stress caused by introduction to the new environment.

##### **Animal husbandry**

10. The temperature of the experimental animal maintenance room should be  $22 \pm 3$  °C. The relative humidity should ideally be maintained in the range of 30 to 70 %, though this may not be possible when using water as a vehicle. Before and after exposures, animals generally should be caged in groups by sex and concentration, but the number of animals per cage should not interfere with clear observation of each animal and should minimise losses due to cannibalism and fighting. When animals are to be exposed nose-only, it may be necessary for them to be acclimated to the restraining tubes. The restraining tubes should not impose undue physical, thermal, or immobilisation stress on the animals. Restraint may affect physiological endpoints such as body temperature (hyperthermia) and/or respiratory minute volume. If generic data are available to show that no such changes occur to any appreciable extent, then pre-adaptation to the restraining tubes is not necessary. Animals

<sup>(1)</sup> The corrosivity evaluation could be based on expert judgment using such evidence as: human and animal experience, existing (*in vitro*) data, e.g. chapter B.40 (10), B.40 bis (11) of this annex or OECD TG 435 (12), pH values, information from similar chemicals or any other pertinent data.

exposed whole-body to an aerosol should be housed individually during exposure to prevent them from filtering the test aerosol through the fur of their cage mates. Conventional and certified laboratory diets may be used, except during exposure, accompanied with an unlimited supply of municipal drinking water. Lighting should be artificial, the sequence being 12 hours light/12 hours dark.

#### **Inhalation chambers**

11. The nature of the test chemical and the objective of the test should be considered when selecting an inhalation chamber. The preferred mode of exposure is nose-only (which term includes head-only, nose-only or snout-only). Nose-only exposure is generally preferred for studies of liquid or solid aerosols and for vapours that may condense to form aerosols. Special objectives of the study may be better achieved by using a whole-body mode of exposure, but this should be justified in the study report. To ensure atmosphere stability when using a whole-body chamber, the total volume of the test animals should not exceed 5 % of the chamber volume. Principles of the nose-only and whole body exposure techniques and their particular advantages and disadvantages are described in GD 39 (8).

#### **EXPOSURE CONDITIONS**

##### **Administrations of concentrations**

12. A fixed duration of exposure for four hours, excluding equilibration time, is recommended. Other durations may be needed to meet specific requirements, however, justification should be provided in the study report [see GD 39 (8)]. Animals exposed in whole-body chambers should be housed individually to prevent ingestion of test chemical due to grooming of cage mates. Feed should be withheld during the exposure period. Water may be provided throughout a whole-body exposure.
13. Animals are exposed to the test chemical as a gas, vapour, aerosol, or a mixture thereof. The physical state to be tested depends on the physico-chemical properties of the test chemical, the selected concentration, and/or the physical form most likely present during the handling and use of the test chemical. Hygroscopic and chemically reactive test chemicals should be tested under dry air conditions. Care should be taken to avoid generating explosive concentrations.

##### **Particle-size distribution**

14. Particle sizing should be performed for all aerosols and for vapours that may condense to form aerosols. To allow for exposure of all relevant regions of the respiratory tract, aerosols with mass median aerodynamic diameters (MMAD) ranging from 1 to 4  $\mu\text{m}$  with a geometric standard deviation ( $\sigma_g$ ) in the range of 1,5 to 3,0 are recommended (8) (13) (14). Although a reasonable effort should be made to meet this standard, expert judgment should be provided if it cannot be achieved. For example, metal fumes may be smaller than this standard, and charged particles, fibres, and hygroscopic materials (which increase in size in the moist environment of the respiratory tract) may exceed this standard.

##### **Test chemical preparation in a vehicle**

15. A vehicle may be used to generate an appropriate concentration and particle size of the test chemical in the atmosphere. As a rule, water should be given preference. Particulate material may be subjected to mechanical processes to achieve the required particle size distribution, however, care should be taken not to decompose or alter the test chemical. In cases where mechanical processes are believed to have altered test chemical composition (e.g. extreme temperature from excessive milling due to friction), the composition of the test chemical should be verified analytically. Adequate care should be taken to not contaminate the test chemical. It is not necessary to test non-friable granular materials which are purposefully formulated to be un-inhalable. An attrition test should be used to demonstrate that respirable particles are not produced when the granular material is handled. If an attrition test produces respirable particles, an inhalation toxicity test should be performed.

##### **Control animals**

16. A concurrent negative (air) control group is not necessary. When a vehicle other than water is used to assist in generating the test atmosphere, a vehicle control group should only be used when historical inhalation toxicity data are not available. If a toxicity study of a test chemical formulated in a vehicle reveals no toxicity, it follows that the vehicle is non-toxic at the concentration tested; thus, there is no need for a vehicle control.

#### **MONITORING OF EXPOSURE CONDITIONS**

##### **Chamber airflow**

17. The flow of air through the chamber should be carefully controlled, continuously monitored, and recorded at least hourly during each exposure. The monitoring of test atmosphere concentration (or stability) is an integral

measurement of all dynamic parameters and provides an indirect means to control all relevant dynamic atmosphere generation parameters. Special consideration should be given to avoiding re-breathing in nose-only chambers in cases where airflow through the exposure system are inadequate to provide dynamic flow of test chemical atmosphere. There are prescribed methodologies that can be used to demonstrate that re-breathing does not occur under the selected operation conditions (8) (15). Oxygen concentration should be at least 19 % and carbon dioxide concentration should not exceed 1 %. If there is reason to believe that these standards cannot be met, oxygen and carbon dioxide concentrations should be measured.

#### **Chamber temperature and relative humidity**

18. Chamber temperature should be maintained at  $22 \pm 3$  °C. Relative humidity in the animals' breathing zone, for both nose-only and whole-body exposures, should be monitored and recorded at least three times for durations up to 4 hrs, and hourly for shorter durations. The relative humidity should ideally be maintained in the range of 30 to 70 %, but this may either be unattainable (e.g. when testing water based mixtures) or not measurable due to test chemical interference with the test method.

#### **Test chemical: nominal concentration**

19. Whenever feasible, the nominal exposure chamber concentration should be calculated and recorded. The nominal concentration is the mass of generated test chemical divided by the total volume of air passed through the chamber system. The nominal concentration is not used to characterise the animals' exposure, but a comparison of the nominal and the actual concentration gives an indication of the generation efficiency of the test system, and thus may be used to discover generation problems.

#### **Test chemical: actual concentration**

20. The actual concentration is the test chemical concentration at the animals' breathing zone in an inhalation chamber. Actual concentrations can be obtained either by specific methods (e.g. direct sampling, adsorptive or chemical reactive methods, and subsequent analytical characterisation) or by non-specific methods such as gravimetric filter analysis. The use of gravimetric analysis is acceptable only for single component powder aerosols or aerosols of low volatility liquids and should be supported by appropriate pre-study test chemical-specific characterisations. Multi-component powder aerosol concentration may also be determined by gravimetric analysis. However, this requires analytical data which demonstrate that the composition of airborne material is similar to the starting material. If this information is not available, a reanalysis of the test chemical (ideally in its airborne state) at regular intervals during the course of the study may be necessary. For aerosolised agents that may evaporate or sublime, it should be shown that all phases were collected by the method chosen. The target, nominal, and actual concentrations should be provided in the study report, but only actual concentrations are used in statistical analyses to calculate lethal concentration values.
21. One lot of the test chemical should be used, if possible, and the test sample should be stored under conditions that maintain its purity, homogeneity, and stability. Prior to the start of the study, there should be a characterisation of the test chemical, including its purity and, if technically feasible, the identity, and quantities of identified contaminants and impurities. This can be demonstrated by, but is not limited to, the following data: retention time and relative peak area, molecular weight from mass spectroscopy or gas chromatography analyses, or other estimates. Although the test sample's identity is not the responsibility of the test laboratory, it may be prudent for the test laboratory to confirm the sponsor's characterisation at least in a limited way (e.g. colour, physical nature, etc.).
22. The exposure atmosphere shall be held as constant as practicable and monitored continuously and/or intermittently depending on the method of analysis. When intermittent sampling is used, chamber atmosphere samples should be taken at least twice in a four hour study. If not feasible due to limited air flow rates or low concentrations, one sample may be collected over the entire exposure period. If marked sample-to-sample fluctuations occur, the next concentrations tested should use four samples per exposure. Individual chamber concentration samples should not deviate from the mean chamber concentration by more than  $\pm 10$  % for gases and vapours, and by no more than  $\pm 20$  % for liquid or solid aerosols. Time to chamber equilibration ( $t_{95}$ ) should be calculated and recorded. The duration of an exposure spans the time that the test chemical is generated and this takes into account the times required to attain  $t_{95}$ . Guidance for estimating  $t_{95}$  can be found in GD 39 (8).
23. For very complex mixtures consisting of vapours/gases, and aerosols (e.g. combustion atmospheres and test chemicals propelled from purpose-driven end-use products/devices), each phase may behave differently in an inhalation chamber so at least one indicator substance (analyte), normally the principal active substance in the mixture, of each phase (vapour/gas and aerosol) should be selected. When the test chemical is a mixture, the analytical concentration should be reported for the total mixture and not just for the active ingredient or the component (analyte). Additional information regarding actual concentrations can be found in GD 39 (8).

**Test chemical: particle size distribution**

24. The particle size distribution of aerosols should be determined at least twice during each 4 hour exposure by using a cascade impactor or an alternative instrument such as an aerodynamic particle sizer. If equivalence of the results obtained by a cascade impactor or an alternative instrument can be shown, then the alternative instrument may be used throughout the study. A second device, such as a gravimetric filter or an impinger/gas bubbler, should be used in parallel to the primary instrument to confirm the collection efficiency of the primary instrument. The mass concentration obtained by particle size analysis should be within reasonable limits of the mass concentration obtained by filter analysis [see GD 39 (8)]. If equivalence can be demonstrated in the early phase of the study, then further confirmatory measurements may be omitted. For animal welfare reasons, measures should be taken to minimize inconclusive data which may lead to a need to repeat an exposure. Particle sizing should be performed for vapours if there is any possibility that vapour condensation may result in the formation of an aerosol, or if particles are detected in a vapour atmosphere with potential for mixed phases (see paragraph 14).

**PROCEDURE****Main test**

25. Three animals per sex, or six animals of the more susceptible sex, are used for each step. If rodent species other than rats are exposed nose-only, maximum exposure durations may be adjusted to minimise species-specific distress. The concentration level to be used as the starting dose is selected from one of four fixed levels and the starting concentration level should be that which is most likely to produce toxicity in some of the dosed animals. The testing schemes for gases, vapours and aerosols (included in Appendixes 2-4) represent the testing with the cut-off values of the CLP categories 1-4 (9) for gases (100, 500, 2 500, 20 000 ppm/4h) (Appendix 2), for vapours (0,5, 2, 10, 20 mg/l/4h) (Appendix 3) and for aerosols (0,05, 0,5, 1, 5 mg/l/4h) (Appendix 4). Category 5, which is not implemented in Regulation (EC) No 1272/2008 (9) relates to concentrations above the respective limit concentrations. For each starting concentration, the respective testing scheme applies. Depending on the number of humanely killed or dead animals, the test procedure follows the indicated arrows until a categorisation can be made.
26. The time interval between exposure groups is determined by the onset, duration, and severity of toxic signs. Exposure of animals at the next concentration level should be delayed until there is reasonable confidence in the survival of the previously tested animals. A period of three or four days between the exposures at each concentration level is recommended to allow for the observation of delayed toxicity. The time interval may be adjusted as appropriate, e.g. in case of inconclusive responses.

**Limit test**

27. The limit test is used when the test chemical is known or expected to be virtually non-toxic, i.e. eliciting a toxic response only above the regulatory limit concentration. Information about the toxicity of the test chemical can be gained from knowledge about similar tested substances or similar mixtures, taking into consideration the identity and percentage of components known to be of toxicological significance. In those situations where there is little or no information about its toxicity, or the test chemical is expected to be toxic, the main test should be performed [further guidance can be found in GD 39 (8)].
28. Using the normal procedure, three animals per sex, or six animals of the more susceptible sex, are exposed at concentrations of 20 000 ppm for gases, 20 mg/l for vapours and 5 mg/l for dusts/mists, respectively (if achievable), which serves as the limit test for this Test Method. When testing aerosols, the primary goal should be to achieve a respirable particle size (i.e. an MMAD of 1-4 µm). This is possible with most test chemicals at a concentration of 2 mg/l. Aerosol testing at greater than 2 mg/l should only be attempted if a respirable particle size can be achieved [see GD 39 (8)]. In accordance with GHS (16), testing in excess of a limit concentration is discouraged for animal welfare reasons. Testing in GHS Category 5 (16), which is not implemented in Regulation (EC) No 1272/2008 (9), should only be considered when there is a strong likelihood that results of such a test would have direct relevance for protecting human health, and justification provided in the study report. In the case of potentially explosive test chemicals, care should be taken to avoid conditions favourable for an explosion. To avoid an unnecessary use of animals, a test run without animals should be conducted prior to the limit test to ensure that the chamber conditions for a limit test can be achieved.

**OBSERVATIONS**

29. The animals should be clinically observed frequently during the exposure period. Following exposure, clinical observations should be made at least twice on the day of exposure, or more frequently when indicated by the response of the animals to treatment, and at least once daily thereafter for a total of 14 days. The length of the observation period is not fixed, but should be determined by the nature and time of onset of clinical signs and length of the recovery period. The times at which signs of toxicity appear and disappear are important, especially if there is a tendency for signs of toxicity to be delayed. All observations are systematically recorded with individual records being maintained for each animal. Animals found in a moribund condition and animals showing severe pain and/or enduring signs of severe distress should be humanely killed for animal

welfare reasons. Care should be taken when conducting examinations for clinical signs of toxicity that initial poor appearance and transient respiratory changes, resulting from the exposure procedure, are not mistaken for treatment-related effects. The principles and criteria summarised in the Humane Endpoints Guidance Document should be taken into consideration (7). When animals are killed for humane reasons or found dead, the time of death should be recorded as precisely as possible.

30. Cage-side observations should include changes in the skin and fur, eyes and mucous membranes, and also respiratory, circulatory, autonomic and central nervous systems, and somato-motor activity and behaviour patterns. When possible, any differentiation between local and systemic effects should be noted. Attention should be directed to observations of tremors, convulsions, salivation, diarrhoea, lethargy, sleep and coma. The measurement of rectal temperatures may provide supportive evidence of reflex bradypnea or hypo/hyperthermia related to treatment or confinement.

#### **Body weights**

31. Individual animal weights should be recorded once during the acclimatisation period, on the day of exposure prior to exposure (day 0) and at least on days 1, 3 and 7 (and weekly thereafter), and at the time of death or euthanasia if exceeding day 1. Body weight is recognised as a critical indicator of toxicity and animals exhibiting a sustained decrement of  $\geq 20\%$ , compared to pre-study values, should be closely monitored. Surviving animals are weighed and humanely killed at the end of the post-exposure period.

#### **Pathology**

32. All test animals, including those which die during the test or are euthanised and removed from the study for animal welfare reasons, should be subjected to gross necropsy. If necropsy cannot be performed immediately after a dead animal is discovered, the animal should be refrigerated (not frozen) at temperatures low enough to minimize autolysis. Necropsies should be performed as soon as possible, normally within a day or two. All gross pathological changes should be recorded for each animal with particular attention to any changes in the respiratory tract.
33. Additional examinations included *a priori* by design may be considered to extend the interpretive value of the study, such as measuring lung weight of surviving rats and/or providing evidence of irritation by microscope examination of the respiratory tract. Examined organs may include those showing evidence of gross pathology in animals surviving 24 or more hours, and organs known or expected to be affected. Microscopic examination of the entire respiratory tract may provide useful information for test chemicals that are reactive with water, such as acids and hygroscopic test chemicals.

### **DATA AND REPORTING**

#### **Data**

34. Individual animal data on body weights and necropsy findings should be provided. Clinical observation data should be summarised in tabular form, showing for each test group the number of animals used, the number of animals displaying specific signs of toxicity, the number of animals found dead during the test or killed for humane reasons, time of death of individual animals, a description and time course of toxic effects and reversibility, and necropsy findings.

#### **Test report**

35. The test report should include the following information, as appropriate:

##### *Test animals and husbandry*

- Description of caging conditions, including: number (or change in number) of animals per cage, bedding material, ambient temperature and relative humidity, photoperiod, and identification of diet;
- Species/strain used and justification for using a species other than the rat;
- Number, age, and sex of animals;
- Method of randomisation;
- Details of food and water quality (including diet type/source, water source);
- Description of any pre-test conditioning including diet, quarantine, and treatment for disease;



*Test chemical*

- Physical nature, purity, and, where relevant, physico-chemical properties (including isomerisation);
- Identification data and Chemical Abstract Services (CAS) Registry Number, if known;

*Vehicle*

- Justification for use of vehicle and justification for choice of vehicle (if other than water);
- Historical or concurrent data demonstrating that the vehicle does not interfere with the outcome of the study;

*Inhalation chamber*

- Description of the inhalation chamber including dimensions and volume;
- Source and description of equipment used for the exposure of animals as well as generation of atmosphere;
- Equipment for measuring temperature, humidity, particle-size, and actual concentration;
- Source of air, treatment of air supplied/extracted and system used for conditioning;
- Methods used for calibration of equipment to ensure a homogeneous test atmosphere;
- Pressure difference (positive or negative);
- Exposure ports per chamber (nose-only); location of animals in the system (whole-body);
- Temporal homogeneity/stability of test atmosphere;
- Location of temperature and humidity sensors and sampling of test atmosphere in the chamber;
- Air flow rates, air flow rate/exposure port (nose-only), or animal load/chamber (whole-body);
- Information about the equipment used to measure oxygen and carbon dioxide, if applicable;
- Time required to reach inhalation chamber equilibrium ( $t_{95}$ );
- Number of volume changes per hour;
- Metering devices (if applicable);

*Exposure data*

- Rationale for target concentration selection in the main study;
- Nominal concentrations (total mass of test chemical generated into the inhalation chamber divided by the volume of air passed through the chamber);
- Actual test chemical concentrations collected from the animals' breathing zone; for test mixtures that produce heterogeneous physical forms (gases, vapours, aerosols), each may be analysed separately;
- All air concentrations should be reported in units of mass (e.g. mg/l, mg/m<sup>3</sup>, etc.), units of volume (e.g. ppm, ppb) may also be reported parenthetically;
- Particle size distribution, mass median aerodynamic diameter (MMAD), and geometric standard deviation ( $\sigma_g$ ), including their methods of calculation. Individual particle size analyses should be reported;



*Test conditions*

- Details of test chemical preparation, including details of any procedures used to reduce the particle size of solid substances or to prepare solutions of the test chemical. In cases where mechanical processes may have altered test chemical composition, include the results of analyses to verify the composition of the test chemical;
- A description (preferably including a diagram) of the equipment used to generate the test atmosphere and to expose the animals to the test atmosphere;
- Details of the chemical analytical method used and method validation (including efficiency of recovery of test chemical from the sampling medium);
- The rationale for the selection of test concentrations;

*Results*

- Tabulation of chamber temperature, humidity, and airflow;
- Tabulation of chamber nominal and actual concentration data;
- Tabulation of particle size data including analytical sample collection data, particle size distribution, and calculations of the MMAD and  $\sigma_g$ ;
- Tabulation of response data and concentration level for each animal (*i.e.* animals showing signs of toxicity including mortality, nature, severity, and duration of effects);
- Individual body weights of animals collected on study days, date and time of death if prior to scheduled euthanasia; time course of onset of signs of toxicity, and whether these were reversible for each animal;
- Necropsy findings and histopathological findings for each animal, if available;
- The CLP category classification and the LC<sub>50</sub> cut-off value;

*Discussion and interpretation of results*

- Particular emphasis should be made to the description of methods used to meet this Test Method's criteria, *e.g.* the limit concentration or the particle size;
- The respirability of particles in light of the overall findings should be addressed, especially if the particle-size criteria could not be met;
- The consistency of methods used to determine nominal and actual concentrations, and the relation of actual concentration to nominal concentration should be included in the overall assessment of the study;
- The likely cause of death and predominant mode of action (systemic versus local) should be addressed;
- An explanation should be provided if there was a need to humanely sacrifice animals in pain or showing signs of severe and enduring distress, based on the criteria in the OECD Guidance Document on Humane Endpoints (7).

*LITERATURE:*

- (1) Chapter B.2 of this Annex, Acute Toxicity (Inhalation).
- (2) Holzhütter H-G, Genschow E, Diener W, and Schlede E (2003). Dermal and Inhalation Acute Toxicity Class Methods: Test Procedures and Biometric Evaluations for the Globally Harmonized Classification System. *Arch. Toxicol.* 77: 243-254.
- (3) Diener W, Kayser D and Schlede E (1997). The Inhalation Acute-Toxic-Class Method; Test Procedures and Biometric Evaluations. *Arch. Toxicol.* 71: 537-549.

- (4) Diener W and Schlede E (1999). Acute Toxic Class Methods: Alternatives to LD/LC<sub>50</sub> Tests. *ALTEX* 1: 129-134.
  - (5) Chapter B.1 tris of this Annex, Acute Oral Toxicity — Acute Toxic Class Method.
  - (6) OECD (2009). Report on Biostatistical Performance Assessment of the Draft TG 436 Acute Toxic Class Testing Method for Acute Inhalation Toxicity. Environmental Health and Safety Monograph Series on Testing and Assessment No 105, OECD, Paris. Available at: [<http://www.oecd.org/env/testguidelines>]
  - (7) OECD (2000). Guidance Document on the Recognition, Assessment and Use of Clinical Signs as Humane Endpoints for Experimental Animals Used in Safety Evaluation. Environmental Health and Safety Monograph Series on Testing and Assessment No 19. Available at: [<http://www.oecd.org/env/testguidelines>]
  - (8) OECD (2009). Guidance Document on Acute Inhalation Toxicity Testing. Environmental Health and Safety Monograph Series on Testing and Assessment No 39, OECD, Paris. Available at: [<http://www.oecd.org/env/testguidelines>]
  - (9) Regulation (EC) No 1272/2008 of the European Parliament and of the Council of 16 December 2008 on classification, labelling and packaging of substances and mixtures, amending and repealing Directives 67/548/EEC and 1999/45/EC, and amending Regulation (EC) No 1907/2006 (OJ L 353, 31.12.2008, p. 1).
  - (10) Chapter B.40 of this Annex, In Vitro Skin Corrosion: Transcutaneous Electrical Resistance Test (TER).
  - (11) Chapter B.40 bis of this Annex, In Vitro Skin Corrosion: Human Skin Model Test.
  - (12) OECD (2005). In Vitro Membrane Barrier Test Method for Skin Corrosion. OECD Guideline for testing of chemicals No 435, OECD, Paris. Available at: [<http://www.oecd.org/env/testguidelines>]
  - (13) Phalen RF (2009). Inhalation Studies: Foundations and Techniques. (2<sup>nd</sup> Edition) Informa Healthcare, New York.
  - (14) SOT (1992). Technical Committee of the Inhalation Specialty Section, Society of Toxicology (SOT). Recommendations for the Conduct of Acute Inhalation Limit Tests. *Fund. Appl. Toxicol.* 18: 321-327.
  - (15) Pauluhn J and Thiel A (2007). A Simple Approach to Validation of Directed-Flow Nose-Only Inhalation Chambers. *J. Appl. Toxicol.* 27: 160-167
  - (16) UN (2007), United Nations Globally Harmonized System of Classification and Labelling of Chemicals (GHS), ST/SG/AC.10/30, UN New York and Geneva. Available: [[http://www.unece.org/trans/danger/publi/ghs/welcome\\_e.html](http://www.unece.org/trans/danger/publi/ghs/welcome_e.html)]
-

*Appendix 1*

## DEFINITION

**Test chemical:** Any substance or mixture tested using this Test Method.

---

*Appendix 2***Procedure to be followed by each of the starting concentrations for gases (ppm/4h)**General remarks <sup>(1)</sup>

For each starting concentration, the respective testing schemes as included in this Appendix outline the procedure to be followed.

Appendix 2a: Starting concentration is 100 ppm

Appendix 2b: Starting concentration is 500 ppm

Appendix 2c: Starting concentration is 2 500 ppm

Appendix 2d: Starting concentration is 20 000 ppm

Depending on the number of humanely killed or dead animals, the test procedure follows the indicated arrows.

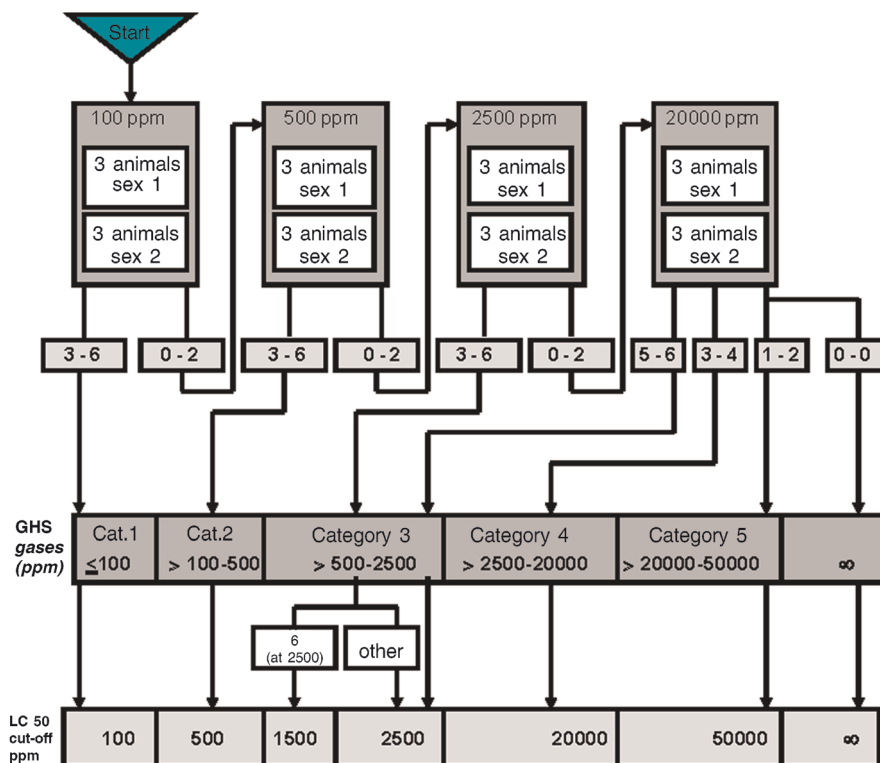
—————

---

<sup>(1)</sup> In the following tables reference is made to GHS (Globally Harmonised System of Classification and Labelling of Chemicals (GHS)). The EU equivalent is Regulation (EC) No 1272/2008. In the case of Acute Inhalation Toxicity, the Regulation (EC) No 1272/2008 (9) does not implement Category 5.

Appendix 2a

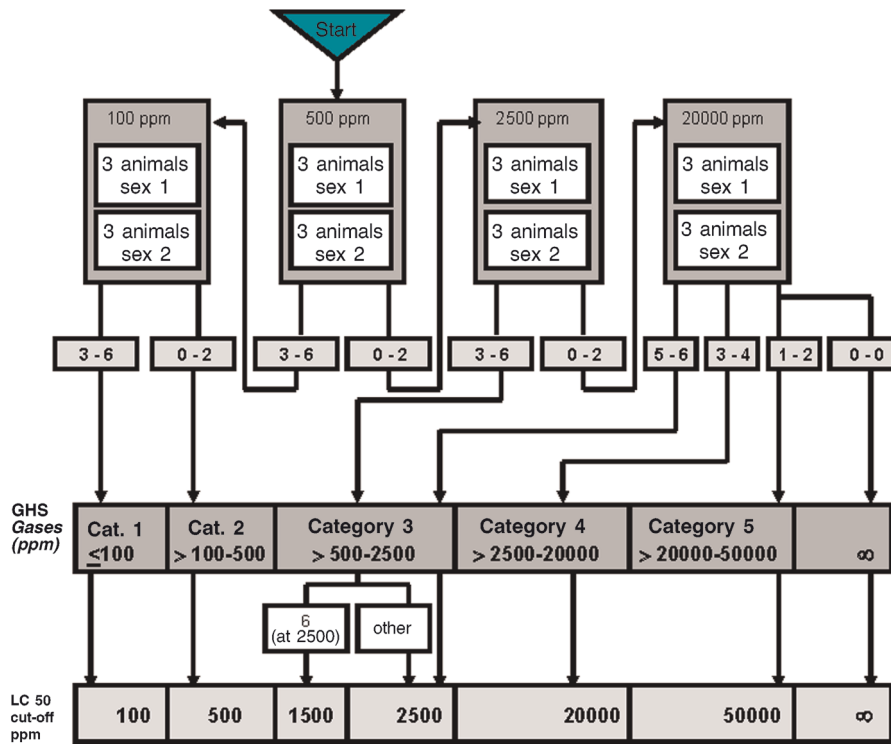
**Acute Inhalation Toxicity:  
Test Procedure with a starting concentration of 100 ppm/4h for gases**



- 3 ♂ + 3 ♀, or 6 animals of the more susceptible sex are used per step
- 0-6: Number of moribund or dead animals/tested concentration
- GHS: Globally Harmonized Classification System
- ∞: unclassified
- Testing at ≥ 20000 ppm/4h: see Guidance Document 39 (8)

Appendix 2b

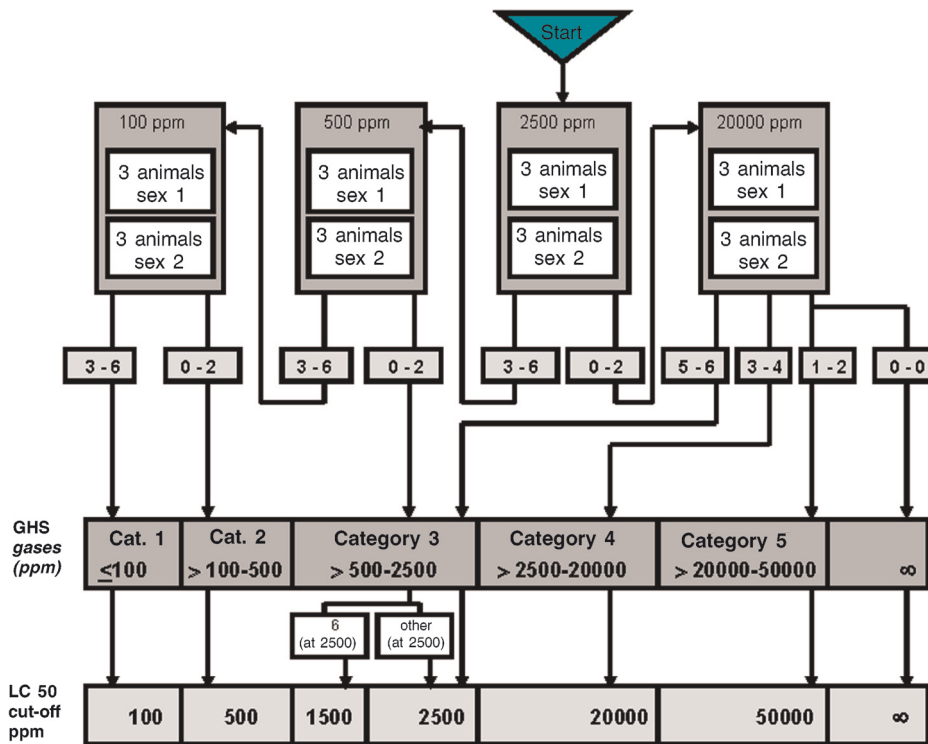
**Acute Inhalation Toxicity:  
Test Procedure with a starting concentration of 500 ppm/4h for gases**



- 3 ♂ + 3 ♀, or 6 animals of the more susceptible sex are used per step
- 0-6: Number of moribund or dead animals/tested concentration
- GHS: Globally Harmonized Classification System
- ∞: unclassified
- Testing at ≥ 20000 ppm/4h: see Guidance Document 39 (8)

Appendix 2c

**Acute Inhalation Toxicity:  
Test Procedure with a starting concentration of 2 500 ppm/4h for gases**

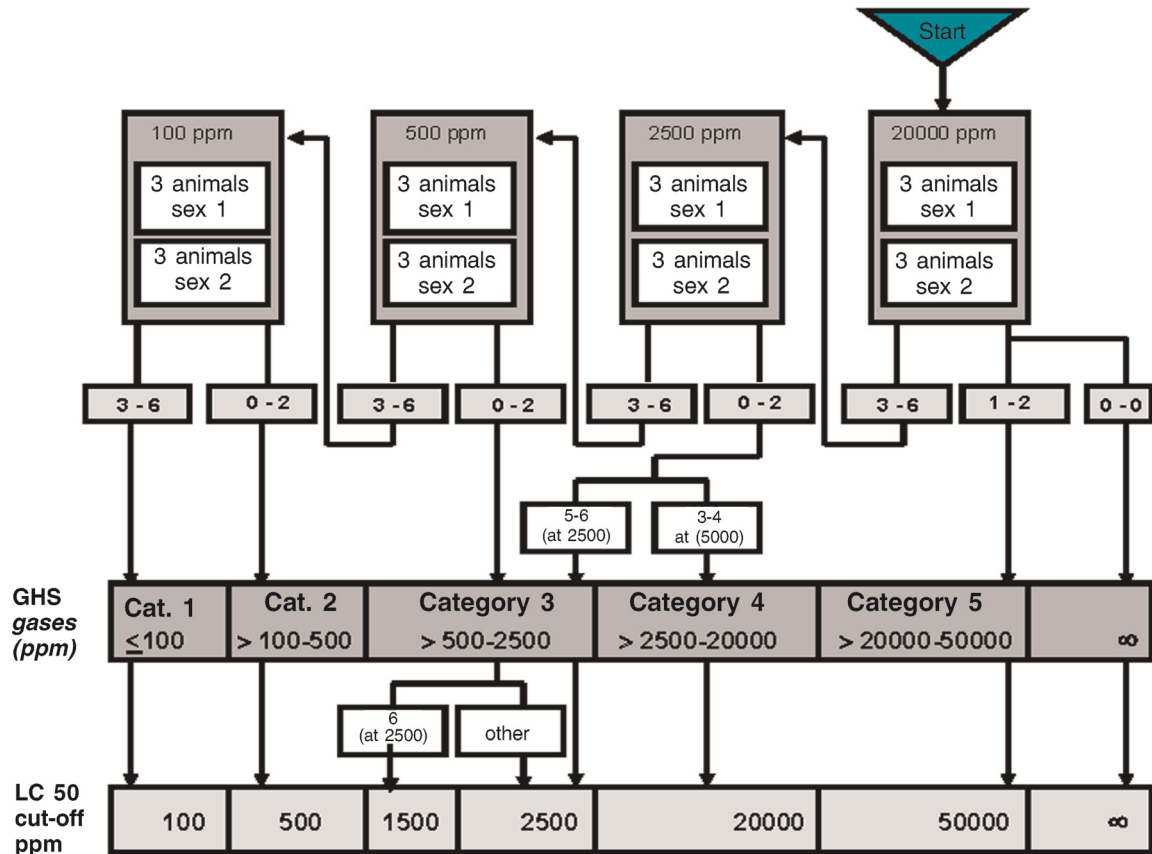


- 3 ♂ + 3 ♀, or 6 animals of the more susceptible sex are used per step
- 0-6: Number of moribund or dead animals/tested concentration
- GHS: Globally Harmonized Classification System
- ∞: unclassified
- Testing at ≥ 20000 ppm/4h: see Guidance Document 39 (8)



Appendix 2d

**Acute Inhalation Toxicity:  
Test Procedure with a starting concentration of 20 000 ppm/4h for gases**



- 3 ♂ + 3 ♀, or 6 animals of the more susceptible sex are used per step
- 0-6: Number of moribund or dead animals/tested concentration
- GHS: Globally Harmonized Classification System
- ∞: unclassified
- Testing at ≥ 20000 ppm/4h: see Guidance Document 39 (8)

*Appendix 3***Procedure to be followed by each of the starting concentrations for vapour (mg/l/4h)**General remarks <sup>(1)</sup>

For each starting concentration, the respective testing schemes as included in this Appendix outline the procedure to be followed.

Appendix 3a: Starting concentration is 0,5 mg/l

Appendix 3b: Starting concentration is 2,0 mg/l

Appendix 3c: Starting concentration is 10 mg/l

Appendix 3d: Starting concentration is 20 mg/l

Depending on the number of humanely killed or dead animals, the test procedure follows the indicated arrows.

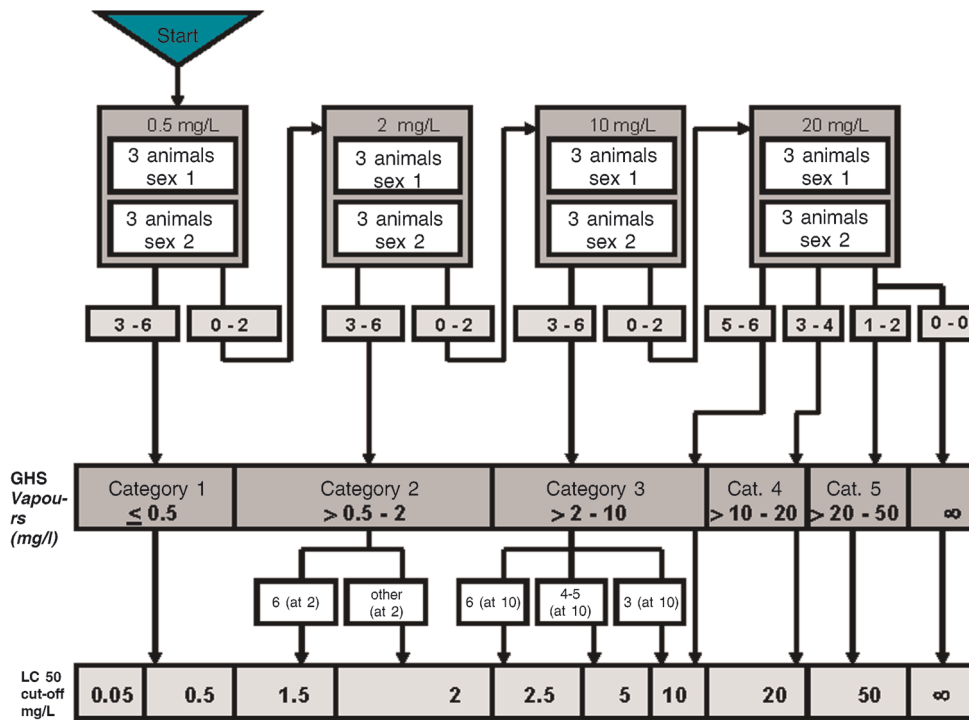
---

<sup>(1)</sup> In the following tables reference is made to GHS (Globally Harmonised System of Classification and Labelling of Chemicals (GHS)). The EU equivalent is Regulation (EC) No 1272/2008. In the case of Acute Inhalation Toxicity, the Regulation (EC) No 1272/2008 (9) does not implement Category 5.

Appendix 3a

Acute Inhalation Toxicity:

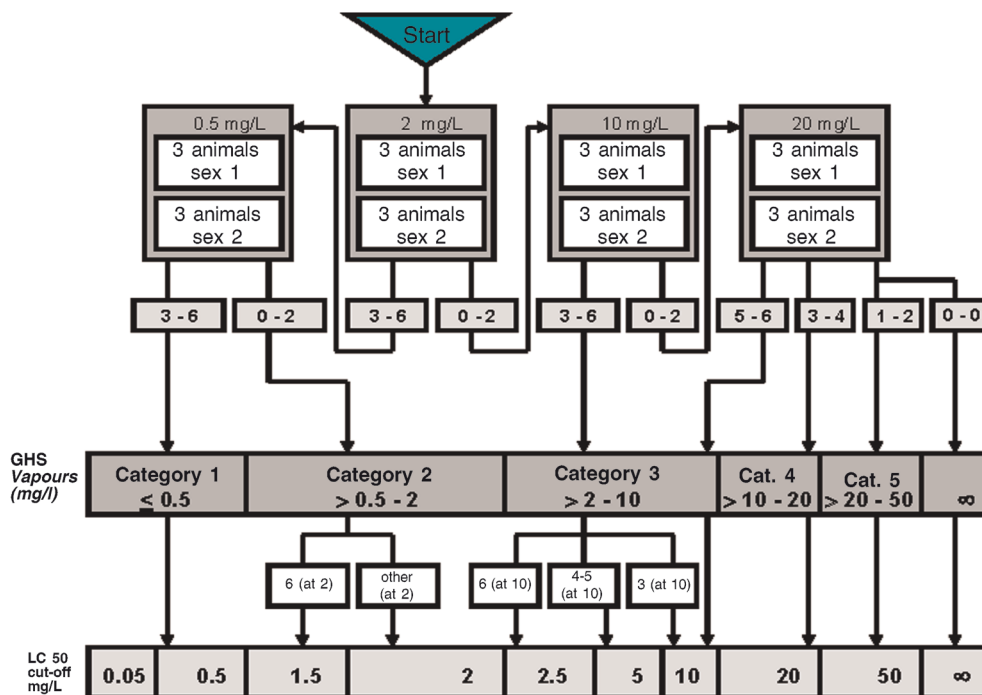
Test procedure with a starting concentration of 0,5 mg/L/4h for vapours



- 3 ♂ + 3 ♀, or 6 animals of the more susceptible sex are used per step
- 0-6: Number of moribund or dead animals/tested concentraion
- GHS: Globally Harmonized Classification System
- ∞: unclassified
- Testing at 50 mg/L/4h: see Guidance Document 39 (8)

Appendix 3b

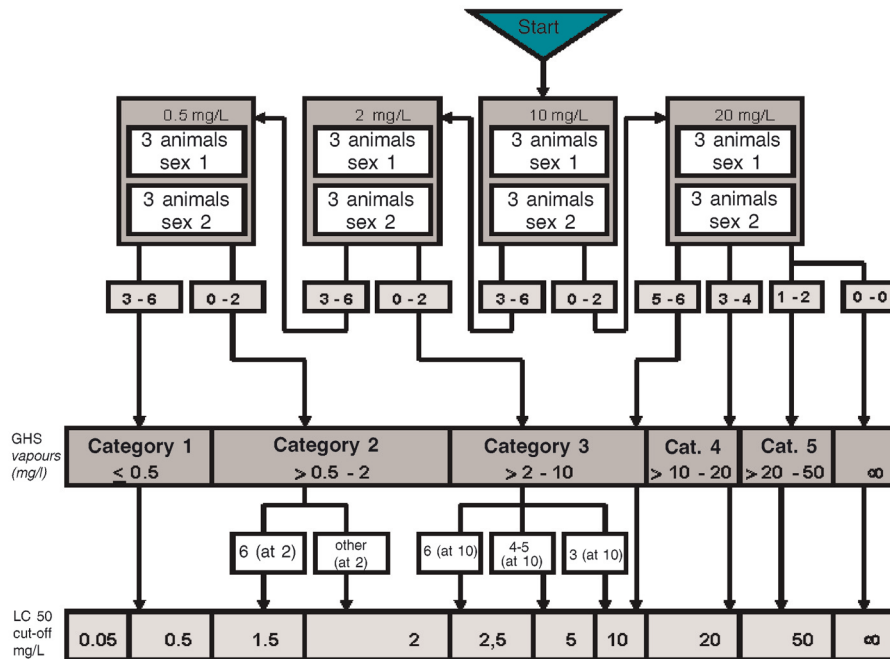
**Acute Inhalation Toxicity:**  
**Test procedure with a starting concentration of 2 mg/L/4h for vapours**



- 3 ♂ + 3 ♀, or 6 animals of the more susceptible sex are used per step
- 0-6: Number of moribund or dead animals/tested concentraion
- GHS: Globally Harmonized Classification System
- ∞: unclassified
- Testing at 50 mg/L4h: see Guidance Document 39 (8)

## Appendix 3c

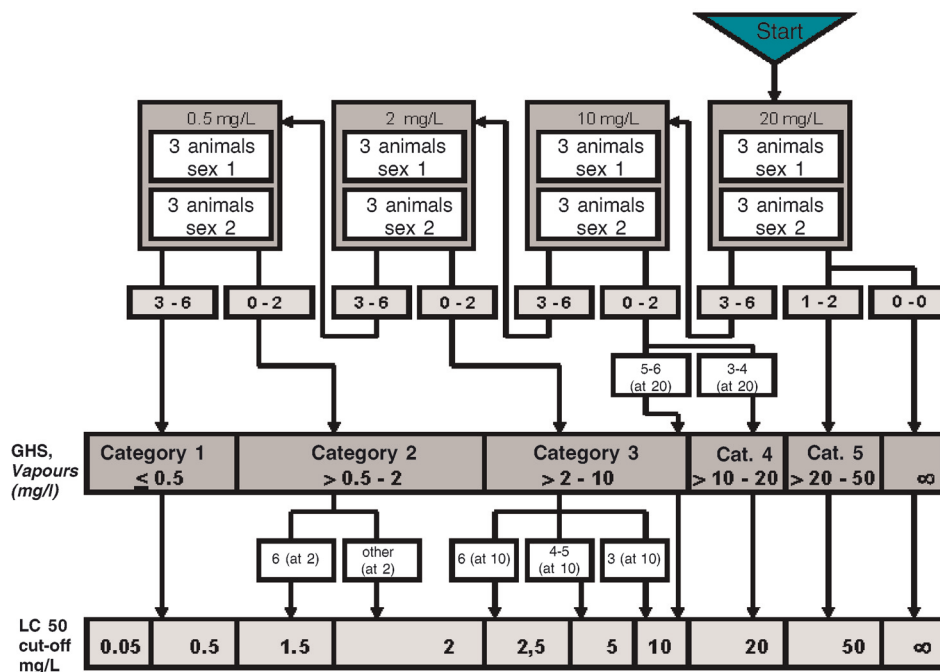
**Acute Inhalation Toxicity:**  
**Test procedure with a starting concentration of 10 mg/L/4h for vapours**



- 3 ♂ + 3 ♀, or 6 animals of the more susceptible sex are used pers step
- 0-6: Number of moribund or dead animals/tested concentraion
- GHS: Globally Harmonized Classification System
- ∞: unclassified
- Testing at 50 mg/L/4h: see Guidance Document 39 (8)

Appendix 3d

**Acute Inhalation Toxicity:**  
**Test procedure with a starting concentration of 20 mg/L/4h for vapours**



- 3 ♂ + 3 ♀, or 6 animals of the more susceptible sex are used per step
- 0-6: Number of moribund or dead animals/tested concentration
- GHS: Globally Harmonized Classification System
- ∞: unclassified
- Testing at 50 mg/L/4h: see Guidance Document 39(8)

*Appendix 4***Procedure to be followed by each of the starting concentrations for aerosols (mg/l/4h)**General remarks <sup>(1)</sup>

For each starting concentration, the respective testing schemes as included in this Appendix outline the procedure to be followed.

Appendix 4a: Starting concentration is 0,05 mg/l

Appendix 4b: Starting concentration is 0,5 mg/l

Appendix 4c: Starting concentration is 1 mg/l

Appendix 4d: Starting concentration is 5 mg/l

Depending on the number of humanely killed or dead animals, the test procedure follows the indicated arrows.

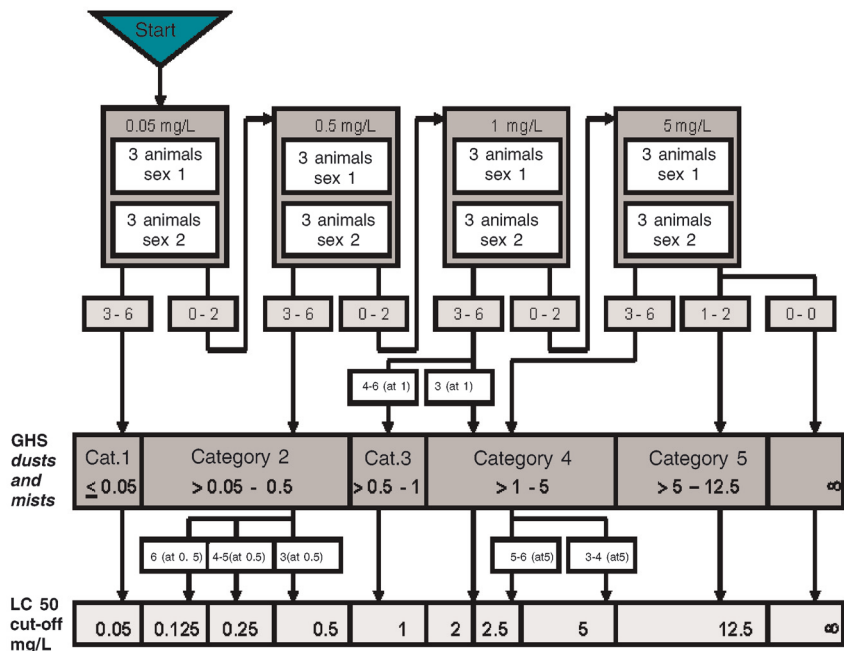
---

<sup>(1)</sup> In the following tables reference is made to GHS (Globally Harmonised System of Classification and Labelling of Chemicals (GHS)). The EU equivalent is Regulation (EC) No 1272/2008. In the case of Acute Inhalation Toxicity the Regulation (EC) No 1272/2008 (9) does not implement Category 5.

Appendix 4a

Acute Inhalation Toxicity:

Test procedure with a starting concentration of 0,05 mg/L/4h for aerosols



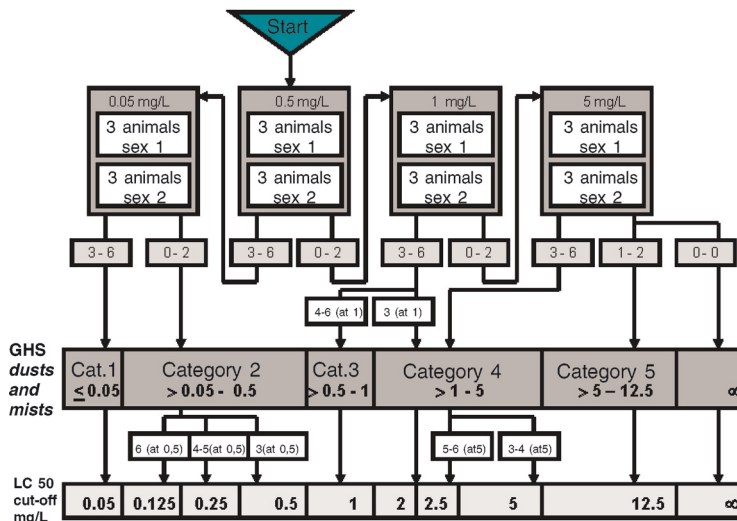
- 3 ♂ + 3 ♀, or 6 animals of the more susceptible sex are used per step
- 0-6: Number of moribund or dead animals/tested concentraion
- GHS: Globally Harmonized Classification System
- ∞: unclassified
- Testing at 12.5 mg/L4h: see Guidance Document 39 (8)



Appendix 4b

Acute Inhalation Toxicity:

Test procedure with a starting concentration of 0,5 mg/L/4h for aerosols

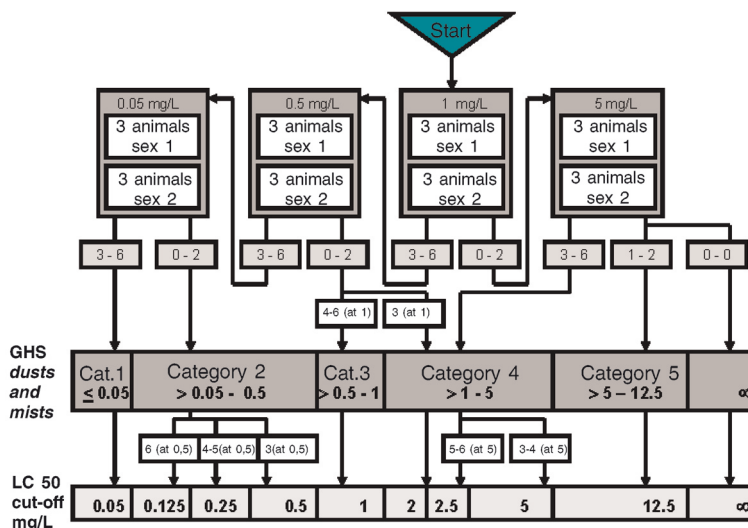


- 3 ♂ + 3 ♀, or 6 animals of the more susceptible sex are used per step
- 0-6: Number of moribund or dead animals/tested concentration
- GHS: Globally Harmonized Classification System
- ∞: unclassified
- Testing at 12.5 mg/L/4h: see Guidance Document 39 (8)

Appendix 4c

Acute Inhalation Toxicity:

Test procedure with a starting concentration of 1 mg/L/4h for aerosols

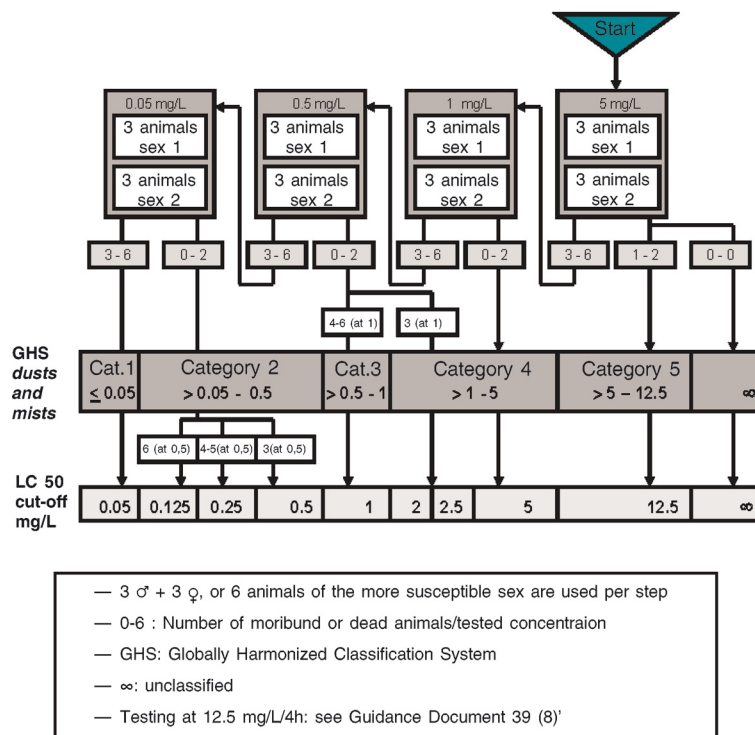


- 3 ♂ + 3 ♀, or 6 animals of the more susceptible sex are used per step
- 0-6: Number of moribund or dead animals/tested concentraion
- GHS: Globally Harmonized Classification System
- ∞: unclassified
- Testing at 12.5 mg/L4h: see Guidance Document 39 (8)

## Appendix 4d

## Acute Inhalation Toxicity:

## Test procedure with a starting concentration of 5 mg/L/4h for aerosols



(9) Chapter C.10 is replaced by the following:

**C.10. SIMULATION TESTAEROBIC SEWAGE TREATMENT: C.10-A: ACTIVATED SLUDGE UNITS — C.10-B: BIOFILMS**

**C.10-A: Activated Sludge Units**

INTRODUCTION

1. This Test Method is equivalent to OECD Test Guideline (TG) 303 (2001). In the 1950s it was realised that the newly introduced surfactants caused excessive foaming in waste water treatment plants and in rivers. They were not fully removed in the aerobic treatment and in some cases limited the removal of other organic matter. This instigated many investigations into how surfactants could be removed from waste waters and whether new chemicals produced by industry were amenable to waste water treatment. In order to do this, model units were used representing the two main types of aerobic biological waste water treatment (activated sludge and percolating, or trickling, filtration). It would have been impractical and very costly to distribute each new chemical and to monitor large-scale treatment plants, even on a local basis.

INITIAL CONSIDERATIONS

**Activated sludge units**

2. Model activated sludge units have been described ranging in size from 300 ml up to about 2 000 ml. Some closely mimicked full-scale plants, having sludge settlement tanks with settled sludge being pumped back to the aeration tank, while others provided no settlement facilities e.g. Swisher (1). The size of the apparatus is a compromise; on the one hand, it must be large enough for successful mechanical operation and for the provision of sufficient volume of samples without affecting the operation, while on the other hand it should not be so large that it demands excessive space and materials.

3. Two forms of apparatus which have been extensively and satisfactorily used are the Husmann units (2) and Porous Pot units (3)(4), first used in the study of surfactants; these are described in this Test Method. Others have also been used satisfactorily, e.g. Eckenfelder (5). Because of the relatively high cost and effort of applying this simulation test, simpler and cheaper screening tests, now embodied in chapter C.4 A-F of this Annex (6) were investigated in parallel. Experience with many surfactants and other chemicals has shown that those which passed the screening tests (readily biodegradable) also degraded in the simulation test. Some of those failing the screening tests passed the inherent biodegradability tests (chapters C.12 (7) and C.19 (8) of this Annex) but only some of this latter group were degraded in the simulation test, while those chemicals which failed tests for inherent biodegradability did not degrade in the simulation tests (9)(10)(11).
4. For some purposes simulation tests carried out under a single set of operating conditions are sufficient; the results are expressed as a percentage removal of the test chemical or of dissolved organic carbon (DOC). A description of such a test is given in this test method. However, unlike the previous version of this chapter, which described only one type of apparatus treating synthetic sewage in the coupled mode using a relatively crude method of sludge wastage, this text offers a number of variations. Alternatives to the type of apparatus, mode of operation, sewage and sludge wastage removal are described. This text closely follows that of ISO 11733 (12), which was carefully scrutinised during its preparation, though the method has not been subject to a ring test.
5. For other purposes the concentration of the test chemical in the effluent is required to be known more accurately and for this a more extensive method is needed. For example, the sludge wastage rate must be more precisely controlled throughout each day and throughout the period of the test, and units have to be run at a number of wastage rates. For a fully comprehensive method, tests should also be run at two or three different temperatures: such a method is described by Birch (13)(14) and summarised in Appendix 6. However, present knowledge is insufficient to decide which of the kinetic models are applicable to the biodegradation of chemicals in waste water treatment and in the aquatic environment generally. The application of Monod kinetics, given in Appendix 6 as an example, is limited to chemicals present at 1 mg/l and above, but in the opinion of some even this remains to be substantiated. Tests at concentrations more truly reflecting those found in waste waters are indicated, in Appendix 7, but such tests, and those in Appendix 6, are included in Appendices instead of being issued as separate Test Methods.

#### *Filters*

6. Much less attention has been given to model percolating filters, perhaps because they are more cumbersome and less compact than activated sludge plant models. Gerike et al developed trickling filter units and operated them in the coupled mode ((15)). These filters were relatively large (height 2 m; volume 60 l) and each required as much as 2 l/h of sewage. Baumann et al (16), simulated trickling filters by inserting polyester "fleece" strips into 1 m tubes (14 mm int. diameter) after the strips had been immersed in concentrated activated sludge for 30 min. The test chemical as sole C source in a mineral salts solution was fed down the vertical tube and biodegradation was assessed from measurements of DOC in the effluent and CO<sub>2</sub> in the issuing gas.
7. Biofilters have been simulated in another way (15); the inner surfaces of rotating tubes, inclined at a small angle to the horizontal, were fed with sewage (about 250 ml/h) with and without the test chemical, and the collected effluents analysed for DOC and/or the specific test chemical.

#### PRINCIPLE OF THE TEST

8. This method is designed to determine the elimination and the primary and/or ultimate biodegradation of water-soluble organic chemicals by aerobic micro-organisms in a continuously operated test system simulating the activated sludge process. An easily biodegradable organic medium and the organic test chemical are the sources of carbon and energy for the micro-organisms.
9. Two continuously operated test units (activated sludge plants or porous pots) are run in parallel under identical conditions which are chosen to suit the purpose of the test. Normally the mean hydraulic retention time is 6 h and the mean sludge age (sludge retention time) is 6 to 10 days. Sludge is wasted by one of two methods, the test chemical is normally added at a concentration of between 10 mg/l dissolved organic carbon (DOC) and 20 mg/l DOC, to the influent (organic medium) of only one of the units. The second unit is used as a control unit to determine the biodegradation of the organic medium.
10. In frequently taken samples of the effluents, the DOC, preferably, or chemical oxygen demand (COD) is determined, together with the concentration of the test chemical (if required) by specific analysis, in the effluent from the unit receiving the test chemical. The difference between the effluent concentrations of DOC or COD in the test and control units is assumed to be due to the test chemical or its organic metabolites. This difference is compared with the influent concentration of DOC or COD due to the added test chemical in order to determine the elimination of the test chemical.

11. Biodegradation may normally be distinguished from bioadsorption by careful examination of the elimination-time curve and may usually be confirmed by applying a test for ready biodegradation using an acclimatised inoculum from the unit receiving the test chemical.

#### INFORMATION ON THE TEST CHEMICAL

12. The purity, water solubility, volatility and adsorption characteristics of the test chemical should be known to enable correct interpretation of results to be made. Normally volatile and insoluble chemicals cannot be tested unless special precautions are taken (see Appendix 5). The chemical structure, or at least the empirical formula, should also be known in order to calculate theoretical values and/or to check measured values of parameters, e.g. theoretical oxygen demand (ThOD), dissolved organic carbon (DOC) and chemical oxygen demand (COD).
13. Information on the toxicity of the test chemical to micro-organisms (see Appendix 4) may be useful for selecting appropriate test concentrations and may be essential for the correct interpretation of low biodegradation values.

#### PASS LEVELS

14. In the original application of this simulation (confirmatory) test to the primary biodegradation of surfactants, a removal of more than 80 % of the specific chemical is required before the surfactant may be marketed. If the value of 80 % is not attained, this simulation (confirmatory) test may be applied and the surfactant may be marketed only if more than 90 % of the specific chemical is removed. With chemicals in general there is no question of pass/fail and the value of percentage removal obtained can be used in proximate calculations of the probable environmental concentration to be used in hazard assessments posed by chemicals. Results tend to follow an all or nothing pattern. In a number of studies of pure chemicals the percentage removal of DOC was found to be > 90 % in more than three quarters and > 80 % in over 90 % of chemicals which showed any significant degree of biodegradability.
15. Relatively few chemicals (e.g. surfactants) are present in sewage at the concentrations (about 10 mg C/l) used in this test. Some chemicals may be inhibitory at these concentrations, while the kinetics of removal of others may be different at low concentrations. A more accurate assessment of the degradation could be made by using modified methods, using realistically low concentrations of the test chemical, and the data collected could be used to calculate kinetic constants. However, the necessary experimental techniques have not yet been fully validated and neither have the kinetic models, which describe the biodegradation reactions, been established (see Appendix 7).

#### REFERENCE CHEMICALS

16. To ensure that the experimental procedure is being carried out correctly, it is useful occasionally to test chemicals whose behaviour is known simultaneously when test chemicals are investigated. Such chemicals include adipic acid, 2-phenyl phenol, 1-naphthol, diphenic acid, 1-naphthoic acid, etc. (9)(10)(11).

#### REPRODUCIBILITY OF TEST RESULTS

17. There have been far fewer reports of studies of simulation tests than of tests for ready biodegradability. Reproducibility between (simultaneous) replicates is good (within 10-15 %) for test chemicals degraded by 80 % or more but for less well degraded chemicals variability is greater. Also, with some borderline chemicals widely disparate results (e.g. 10 %, 90 %) have been recorded on different occasions within the 9 weeks allowed in the test.
18. Little difference has been found in results obtained with the two types of apparatus, but some chemicals have been more extensively and consistently degraded in the presence of domestic sewage than with OECD synthetic sewage.

#### DESCRIPTION OF THE TEST METHOD

##### **Apparatus**

##### *Test system*

19. The test system for one test chemical consists of a test unit and a control unit; but when only specific analyses are performed (primary biodegradation) only a test unit is required. One control unit can be used for several test units receiving either the same or different test chemicals. In the case of coupling (Appendix 3) each test unit must have its own control unit. The test system may be either an activated sludge plant model, Husmann unit (Appendix 1, Figure 1) or a porous pot (Appendix 1, Figure 2). In both cases storage vessels of sufficient size for the influents and effluents are needed, as well as pumps to dose the influent, either mixed with solution of the test chemical or separately.

20. Each activated sludge plant unit consists of an aeration vessel with a known capacity of about 3 litres of activated sludge and a separator (secondary clarifier) which holds about 1,5 litres; the volumes can, to some extent, be changed by adjusting the height of the separator. Vessels of different sizes are permissible if they are operated with comparable hydraulic loads. If it is not possible to keep the temperature in the test room in the desired range, the use of water-jacketed vessels with temperature controlled water is recommended. An airlift pump or a dosing pump is used to recycle the activated sludge from the separator to the aeration vessel, either continuously or intermittently at regular intervals.
21. The porous pot system consists of an inner, porous cylinder with a conical bottom held in a slightly larger vessel of the same shape, but made of an impervious plastic material. A suitable material for the porous vessel is porous polyethylene of maximum pore size 90 µm and 2 mm thickness. Separation of the sludge from the treated organic medium is effected by differential passage through the porous wall. Effluents collect in the annular space from where it overflows into the collecting vessel. No settlement occurs and hence there is no sludge return. The whole system may be mounted in a thermostatically controlled water-bath. Porous pots become blocked and could overflow in the initial stages. In such a case, replace the porous liner with a clean one by first siphoning the sludge from the pot into a clean bucket and removing the blocked liner. After wiping out the impervious outer cylinder insert a clean liner and return the sludge to the pot. Any sludge adhering to the sides of the blocked liner is also carefully scraped off and transferred. Clean blocked pots first by using a fine jet of water to remove remaining sludge and by soaking in dilute sodium hypochlorite solution, then in water, followed by thoroughly rinsing with water.
22. For aeration of the sludge in the aeration vessels of both systems, suitable techniques are required, for example sintered cubes (diffuser stones) and compressed air. The air shall be cleaned, if necessary, by passing through a suitable filter and washed. Sufficient air must pass through the system to maintain aerobic conditions and to keep sludge flocs in suspension at all times during the test.

#### *Filtration apparatus or centrifuge*

23. Device for filtration of samples with membrane filters of suitable porosity (nominal aperture diameter 0,45 µm) which adsorb soluble organic chemicals and release organic carbon to a minimum degree. If filters are used which release organic carbon, wash the filters carefully with hot water to remove leachable organic carbon. Alternatively, a centrifuge capable of producing 40 000 m/s<sup>2</sup> may be used.

#### *Analytical equipment*

24. Apparatus required to determine:
  - DOC(dissolved organic carbon) and TOC (total organic carbon), or COD (chemical oxygen demand);
  - specific chemical, if required;
  - suspended solids, pH, oxygen concentration in water;
  - temperature, acidity and alkalinity;
  - ammonium, nitrite and nitrate, if the test is performed under nitrifying conditions.

#### *Water*

25. Tap water, containing less than 3 mg/l DOC. Determine the alkalinity if not already known.
26. Deionised water, containing less than 2 mg/l DOC.

#### *Organic medium*

27. Synthetic sewage, domestic sewage or a mixture of both is permissible as the organic medium. It has been shown (11)(14) that the use of domestic sewage alone often gives increased percentage DOC removal and even allows the removal and biodegradation of some chemicals which are not biodegraded when OECD synthetic sewage is used. Also, the constant or intermittent addition of domestic sewage often stabilises the activated sludge, including the crucial ability to settle well. Thus, the use of domestic sewage is recommended. Measure the DOC or COD concentration in each new batch of organic medium. The acidity or alkalinity of the organic medium should be known. The organic medium may require the addition of a suitable buffer (sodium hydrogen carbonate or potassium dihydrogen phosphate) if it is of low acidity or alkalinity, to maintain a pH of about 7,5 ± 0,5 in the aeration vessel during the test. The amount of buffer to be added, and when to add it, has to be decided in each individual case. When mixtures are used either continuously or intermittently, the DOC (or COD) of the mixture must be kept at an approximately constant value, e.g. by dilution with water.

*Synthetic sewage*

28. Dissolve in each litre of tap water: peptone, 160 mg; meat extract, 110 mg; urea, 30 mg; anhydrous dipotassium hydrogen phosphate ( $K_2HPO_4$ ), 28 mg; sodium chloride (NaCl), 7 mg; calcium chloride dihydrate ( $CaCl_2 \cdot 2H_2O$ ), 4 mg; magnesium sulphate heptahydrate ( $Mg_2SO_4 \cdot 7H_2O$ ), 2 mg. This OECD synthetic sewage is an example and gives a mean DOC concentration in the influent of about 100 mg/l. Alternatively, use other compositions, with about the same DOC concentration, which are closer to real sewage. If a less concentrated influent is required, dilute the synthetic sewage, for example 1:1, with tap water to obtain a concentration of about 50 mg/l. Such a weaker influent will allow better growth of nitrifying organisms and this modification should be used if the simulation of nitrifying waste water plants is to be investigated. This synthetic sewage may be made up in distilled water in a concentrated form and stored at about 1 °C for up to one week. When needed, dilute with tap water. (This medium is unsatisfactory e.g. nitrogen concentration is very high, relatively low carbon content, but nothing better has been suggested, except to add more phosphate as buffer and extra peptone).

*Domestic sewage*

29. Use fresh settled sewage collected daily from a treatment works receiving predominantly domestic sewage. It should be collected, prior to primary sedimentation, from the overflow channel of the primary sedimentation tank, or from the feed to the activated sludge plant, and be largely free from coarse particles. The sewage can be used after storage for several days (but generally should not exceed seven days) at about 4 °C, if it is proved that the DOC (or COD) has not significantly decreased (i.e. by less than 20 %) during storage. In order to limit disturbances to the system, the DOC (or COD) of each new batch should be adjusted before use to an appropriate constant value, e.g. by dilution with tap water.

*Activated sludge*

30. Collect activated sludge for inoculation from the aeration tank of a well operated waste water treatment plant or from a laboratory — scale activated sludge unit, treating predominantly domestic sewage.

*Stock solutions of test chemical*

31. For chemicals of adequate solubility, prepare stock solutions at appropriate concentrations (e.g. 1 to 5 g/l) in deionised water, or in the mineral portion of the synthetic sewage. (for insoluble and volatile chemicals, see Appendix 5). Determine the DOC and total organic carbon (TOC) of the stock solution and repeat the measurements for each new batch. If the difference between the DOC and TOC is greater than 20 %, check the water-solubility of the test chemical. Compare the DOC or the concentration of the test chemical measured by specific analysis of the stock solution with the nominal value, to ascertain whether recovery is good enough (normally > 90 % can be expected). Ascertain, especially for dispersions, whether or not DOC can be used as an analytical parameter or if only an analytical technique specific for the test chemical can be used. Centrifugation of the samples is required for dispersions. For each new batch, measure the DOC, COD or the test chemical with specific analysis.
32. Determine the pH of the stock solution. Extreme values indicate that the addition of the chemical may have an influence on the pH of the activated sludge in the test system. In this case neutralise the stock solution to obtain a pH of  $7 \pm 0,5$  with small amounts of inorganic acid or base, but avoid precipitation of the test chemical.

## PROCEDURE

33. The procedure is described for the activated sludge plant units; it has to be slightly adapted for the porous pot system.

*Preparation of the inoculum*

34. Inoculate the test system at the beginning of the test with either activated sludge or an inoculum containing a low concentration of micro-organisms. Keep the inoculum aerated at room temperature until it is used and use it within 24 h. In the first case, take a sample of activated sludge from the aeration tank of an efficiently operated biological waste water treatment plant, or a laboratory treatment plant, which receives predominantly domestic sewage. If nitrifying conditions are to be simulated, take sludge from a nitrifying waste water treatment plant. Determine the concentration of suspended solids and, if necessary, concentrate the sludge by settling so that the volume added to the test system is minimal. Ensure that the starting concentration of dry matter is about 2,5 g/l.
35. In the second case, use 2 ml/l to 10 ml/l of an effluent from a domestic biological waste water treatment plant as an inoculum. To get as many different species of bacteria as possible, it may be helpful to add inocula from various other sources, for example surface water. In this case, the activated sludge will develop and grow in the test system.



*Dosage of organic medium*

36. Ensure that influent and effluent containers and tubing from influent vessels and to effluent vessels are thoroughly cleaned to remove microbial growths initially and throughout the test. Assemble the test systems in a room where the temperature is controlled (normally in the range 20-25 °C) or use water-jacketed test units. Prepare a sufficient volume of the required organic medium (paragraphs 27-29). Initially fill the aeration vessel and the separator with the organic medium and add the inoculum (paragraphs 34, 35). Start the aeration such that the sludge is kept in suspension and in an aerobic state and begin dosing the influent and recycling the settled sludge. Dose organic medium out of storage vessels into the aeration vessels (paragraphs 20, 21) of the test and control units and collect the respective effluents in similar storage vessels. To get the normal hydraulic retention time of 6 h, the organic medium is pumped at 0,5 l/h. To confirm this rate, measure the daily amount of organic medium dosed by noting the reduction in volumes of the medium in the storage vessels. Other modes of dosing would be necessary for determining the effects of intermittent release and "shock" loading of chemicals.
37. If the organic medium is prepared for use for a period longer than 1 day, cooling at about 4 °C, or other appropriate methods of conservation are necessary to prevent microbial growth and biodegradation outside the test units (paragraph 29). If synthetic sewage is used, it is possible to prepare, and store at about 4 °C, a concentrated stock solution (e.g. 10-fold the normal concentration, paragraph 28). This stock solution can be well mixed with the appropriate volume of tap water before use; alternatively, it can be pumped directly while the appropriate amount of tap water is pumped separately.

*Dosage of test chemical*

38. Add an appropriate volume of the stock solution of the test chemical (paragraph 31) to the storage vessel of the influent or dose it directly with a separate pump into the aeration vessel. The normal mean test concentration in the influent should be between 10 mg/l and 20 mg/l DOC, with an upper concentration of no more than 50 mg/l. If the water-solubility of the test chemical is low or if toxic effects are likely to occur, reduce the concentration to 5 mg/l DOC or even less, but only if a suitable specific analytical method is available and performed (dispersed test chemicals which are poorly soluble in water may be added using special dosing techniques, see Appendix 5).
39. Start adding the test chemical after a period in which the system has stabilised and is removing DOC of the organic medium efficiently (about 80 %). It is important to check that all units are working equally efficiently before the addition of test chemical; if they are not, it usually helps to mix the individual sludges and to re-disperse equal volumes to individual units. When an inoculum of (about) 2,5 g/l (dry weight) activated sludge is used, the test chemical may be added from the start of the test since directly adding increasing amounts from the beginning has the advantage that the activated sludge may be better able to adapt to the test chemical. In whatever manner the test chemical is added, it is recommended that the relevant flow rate and/or the volumes in the storage vessel(s) are measured at regular intervals.

*Handling of activated sludge*

40. The concentration of activated sludge solids normally stabilises between limits during the test, independent of the inoculum used, in the range 1 to 3 g/l (dry weight) depending on the quality and concentration of the organic medium, operating conditions, the nature of the micro-organisms present and the influence of the test chemical.
41. Either determine the suspended solids in the aeration vessels at least weekly and discard surplus sludge to maintain the concentration at 1 g/l to 3 g/l (dry weight), or control the mean sludge age at a constant value usually in the range 6 days to 10 days. If, for example, a sludge retention time of 8 days is chosen, remove daily 1/8 of the volume of the activated sludge in the aeration vessel and discard it. Carry this out on a daily basis or, preferably, by means of an automatic intermittently operating pump. Maintaining the concentration of suspended solids constant, or within narrow limits, does not maintain a constant sludge retention time (SRT), which is the operating variable that determines the value of the concentration of test chemical in the effluent.
42. Throughout the test, remove, at least daily, any sludge adhering to the walls of the aeration vessel and the separator so that it is resuspended. Check and clean regularly all tubes and tubing to prevent growth of biofilm. Recycle the settled sludge from the separator to the aeration vessel, preferably by intermittent pumping. No recycling takes place in the porous pot system but ensure that clean inner pots are inserted before the volume in the vessel rises significantly (paragraph 21).
43. Poor settlement and loss of sludge may occur in the Husmann plant units. These may be rectified by employing one or more of the actions, listed below, in parallel in test and control units:



- fresh sludge or flocculant (for example 2 ml/vessel of 50 g/l  $\text{FeCl}_3$ ) could be added at regular intervals, e.g. weekly, but ascertain that no reaction or precipitation of the test chemical occurs with  $\text{FeCl}_3$ ;
- the air-lift pump could be replaced by a peristaltic pump, thus enabling a sludge recirculation flow which about equals the influent flow to be used and allowing development of an anaerobic zone in the settled sludge (the geometry of the air-lift pump limits the minimum flow rate of returned sludge to be about 12-fold that of the influent);
- sludge could be pumped intermittently from the separator to the aeration vessel (e.g. 5 min. every 2,5 h to recycle 1 l/h to 1,5 l/h);
- a non-toxic, anti-foaming agent at minimal concentration could be used to prevent loss by foaming (e.g. silicone oil);
- air could be passed through the sludge in the separator in short, shock bursts (e.g. 10 sec. every hour);
- the organic medium may be dosed at intervals into the aeration vessel (e.g. 3 min. to 10 min. every hour).

#### *Sampling and analysis*

44. At regular intervals measure the dissolved oxygen concentration, the temperature and the pH value of the activated sludge in the aeration vessels. Ensure that sufficient oxygen is always available ( $> 2 \text{ mg/l}$ ) and that the temperature is kept in the required range (normally  $20 \text{ }^\circ\text{C}$  to  $25 \text{ }^\circ\text{C}$ ). Keep the pH at  $7,5 \pm 0,5$  by dosing small amounts of inorganic base or acid into the aeration vessel or into the influent, or by increasing the buffering capacity of the organic medium (see paragraph 27). When nitrification occurs acid is produced, the oxidation of 1 mg N producing the equivalent of about  $7 \text{ mg CO}_3^-$ . The frequency of measuring depends on the parameter to be measured and the stability of the system, and may vary between daily and weekly measurements.
45. Measure the DOC or COD in the influents to the control and test vessels. Measure the test chemical concentration in the test influent by specific analysis or estimate it from the concentration in the stock solution (paragraph 31), the volume used and the amount of sewage dosed into the test unit. It is recommended that the concentration of the test chemical be calculated in order to reduce the variability of the concentration data.
46. Take suitable samples from the collected effluent (e.g. 24 h composites) and filter through a membrane of pore size  $0,45 \text{ }\mu\text{m}$  or centrifuge them at about  $40,000 \text{ m/s}^2$  for about 15 min. Centrifuging should be used if filtering is difficult. Determine DOC or COD at least in duplicate to measure ultimate biodegradation and, if required, primary biodegradation by an analysis specific for the test chemical.
47. The use of COD may give rise to analytical problems at low concentrations and is therefore recommended only if a sufficiently high test concentration (about  $30 \text{ mg/l}$ ) is used. Also, for strongly adsorbing chemicals, it is recommended that the amount of adsorbed chemical in the sludge be measured using an analytical technique specific for the test chemical.
48. The frequency of sampling depends on the expected duration of the test. A recommended frequency is three times per week. Once the units are operating efficiently, allow from 1 week to a maximum of 6 weeks after the test chemical has been introduced, for adaptation to reach a steady state. Preferably obtain at least 15 valid values in the plateau phase (paragraph 59), normally lasting 3 weeks, for the evaluation of the test result. The test may be completed if a sufficient degree of elimination is reached (e.g.  $> 90 \%$ ) and these 15 values, which represent analyses carried out each weekday over 3 weeks, are available. Normally, do not exceed a test duration of more than 12 weeks after addition of the test chemical.
49. If the sludge nitrifies and if the effects of the test chemical on nitrification are to be studied, analyse samples from the effluent of the test and control units at least once per week for ammonium and/or nitrite plus nitrate.
50. All analyses should be performed as soon as possible, especially the nitrogen determinations. If analyses have to be postponed, store the samples at about  $4 \text{ }^\circ\text{C}$  in the dark in full, tightly stopped bottles. If samples have to be stored for more than 48 h, preserve them by deep-freezing, acidification (e.g. 10 ml/l of a 400 g/l solution of sulphuric acid) or by addition of a suitable toxic substance (e.g. 20 ml/l of a 10 g/l solution of mercury (II) chloride). Ensure that the preservation technique does not influence results of analysis.

*Coupling of test units*

51. If coupling is to be used (Appendix 3), daily exchange the same amount of activated sludge (150 ml to 1 500 ml for aeration vessels containing 3 litres of liquor) between the aeration vessels of the test unit and its control unit. If the test chemical adsorbs strongly onto the sludge, change only the supernatant of the separators. In both cases use a correction factor to calculate the test results (paragraph 55).

## DATA AND REPORTING

**Treatment of results**

52. Calculate the percentage of DOC or COD elimination of the test chemical for each timed assessment, using the equation:

$$D_t = \frac{C_s - (E - E_o)}{C_s} \times 100$$

where

$D_t$  = % elimination of DOC or COD at time t

$C_s$  = DOC or COD in the influent due to the test chemical, preferably estimated from the stock solution (mg/l)

$E$  = measured DOC or COD value in the test effluent at time t (mg/l)

$E_o$  = measured DOC or COD value in the control effluent at time t (mg/l)

53. The degree of DOC or COD elimination of the organic medium in the control unit is helpful information in assessing the biodegradative activity of the activated sludge during the test. Calculate the percentage elimination from the equation:

$$D_B = \frac{C_M - E_o}{C_M} \times 100$$

where

$D_B$  = % elimination of DOC or COD of the organic medium in the control unit at time t

$C_M$  = DOC or COD of the organic medium in the control influent (mg/l)

Optionally, calculate the percentage elimination DOC or COD due to the organic medium plus test chemical in the test unit from the equation:

$$D_T = \frac{C_T - E}{C_T} \times 100$$

where

$D_T$  = % elimination of total test influent DOC or COD

$C_T$  = DOC or COD of total test influent or calculated from stock solutions (mg/l)

54. Calculate the removal of the test chemical if measured with a specific analytical method at each time assessment from equation:

$$D_{ST} = \frac{S_i - S_e}{S_i} \times 100$$

where

$D_{ST}$  = % primary elimination of test chemical at time t

$S_i$  = measured or estimated test chemical concentration in the test influent (mg/l)

$S_e$  = measured test chemical concentration in test effluent at time t (mg/l)

55. If the coupling mode has been used, compensate the dilution of the test chemical in the aeration vessel by the sludge exchange using a correction factor (see Appendix 3). If a mean hydraulic retention time of 6 h and an exchange of half of the volume of the activated sludge in the aeration vessel have been used, the determined daily elimination values ( $D_t$ , paragraph 52) have to be corrected to obtain the true degree of elimination,  $D_{tc}$ , of the test chemical from the equation:

$$D_{tc} = \frac{4D_t - 100}{3}$$

#### Expression of test results

56. Plot the percentage elimination  $D_t$  (or  $D_{tc}$ ) and  $D_{st}$ , if available, versus time (see Appendix 2). From the shape of the elimination curve of the test chemical (*per se* or as DOC) some conclusions may be drawn about the removal process.

#### Adsorption

57. If a high DOC elimination of the test chemical is observed from the beginning of the test, the test chemical is probably eliminated by adsorption onto the activated sludge solids. It is possible to prove this by determining the adsorbed test chemical by specific analysis. It is not usual for the elimination of DOC of adsorbable chemicals to remain high throughout the test; normally, there is a high degree removal initially which gradually falls to an equilibrium value. If, however, the adsorbable test chemical was able to cause acclimation of the microbial population in some way or other, the DOC elimination of the test chemical would subsequently increase and reach a high plateau value.

#### Lag phase

58. As in static, screening tests, many test chemicals require a lag phase before full biodegradation occurs. In the lag phase, acclimation or adaptation of the degrading bacteria takes place with almost no removal of the test chemical; then the initial growth of these bacteria occurs. This phase ends and the degradation phase is taken to begin when about 10 % of the initial amount of test chemical is removed (after allowing for adsorption, if it occurs). The lag phase is often highly variable and poorly reproducible.

#### Plateau phase

59. The plateau phase of an elimination curve in a continuous test is defined as that phase in which the maximum degradation takes place. The plateau phase should be at least 3 weeks and have about 15 measured valid values.

#### Mean degree of elimination of test chemical

60. Calculate the mean value from the elimination values ( $D_t$ ) of the test chemical at the plateau phase. Rounded to the nearest whole number (1 %), it is the degree of elimination of the test chemical. It is also recommended to calculate the 95 % confidence interval of the mean value.

#### Elimination of organic medium

61. Plot the percentage of elimination of the DOC or COD of the organic medium in the control unit ( $D_B$ ) versus time. Indicate the mean degree of elimination in the same way as for the test chemical (paragraph 60).

#### Indication of biodegradation

62. If the test chemical does not adsorb significantly on to activated sludge and the elimination curve has a typical shape of a biodegradation curve with lag, degradation and plateau phases (paragraphs 58, 59), the measured elimination can safely be attributed to biodegradation. If a high initial removal has taken place, the simulation test cannot differentiate between biological and abiotic elimination processes. In such cases, and in other cases where there is any doubt about biodegradation (e.g. if stripping takes place), analyse adsorbed test chemicals or perform additional static biodegradation tests based on parameters clearly indicating biological processes. Such tests are the oxygen uptake methods (chapter C.4 D, E and F of this Annex (6)) or a test with measurement of carbon dioxide production (chapter C.4 C of this Annex (6)) or the ISO Headspace method (18), using a pre-exposed inoculum from the simulation test. If both the DOC removal and specific chemical removal have been measured, significant differences (the former being lower than the latter) between the percentages removed indicate the presence in the effluents of intermediate organic products which may be more difficult to degrade than the parent chemical.

*Validity of test results*

63. Information on the normal biodegradation behaviour of the inoculum is achieved if the degree of elimination of the organic medium (paragraph 53) in the control unit is determined. Consider the test to be valid if the degree of DOC or COD elimination in the control unit(s) is  $> 80\%$  after two weeks and no unusual observations have been made.
64. If a readily biodegradable (reference) chemical has been used, the degree of biodegradation ( $D_t$ , paragraph 52) should be  $> 90\%$ .
65. If the test is performed under nitrifying conditions, the mean concentration in the effluents should be  $< 1$  mg/l ammonia-N and  $< 2$  mg/l nitrite-N.
66. If these criteria (paragraphs 63-65) are not met, repeat the test using an inoculum from a different source, test a reference chemical, and review all experimental procedures.

**Test Report**

67. The test report must include the following:

*Test chemical:*

- identification data;
- physical nature and, where relevant, physical-chemical properties.

*Test conditions:*

- type of test system; any modifications for testing insoluble and volatile chemicals;
- type of organic medium;
- proportion and nature of industrial waste waters in sewage, if known;
- inoculum, nature and sampling site(s), concentration and any pre-treatment;
- test chemical stock solution: DOC and TOC content; how prepared, if suspension; test concentration used; reasons if outside range of 10-20 mg/l DOC; method of addition; date first added; any changes;
- mean sludge age and mean hydraulic retention time; method of sludge wastage; methods of overcoming bulking, loss of sludge, etc.;
- analytical techniques employed;
- test temperature;
- qualities of the sludge-bulking, sludge volume index (SVI), mixed liquor suspended solids (MLSS);
- any deviations from standard procedures and any circumstances which may have affected results.

*Test results:*

- all measured data (DOC, COD, specific analyses, pH, temperature, oxygen concentration, suspended solids, N chemicals, if relevant);
- all calculated values of  $D_t$  (or  $D_{tc}$ ),  $D_B$ ,  $D_{St}$  obtained in tabular form and the elimination curves;
- information on lag and plateau phases, test duration, the degree of elimination of the test chemical and that of the organic medium in the control unit, together with statistical information and statements of biodegradability and validity of the test;
- discussion of results.

## LITERATURE:

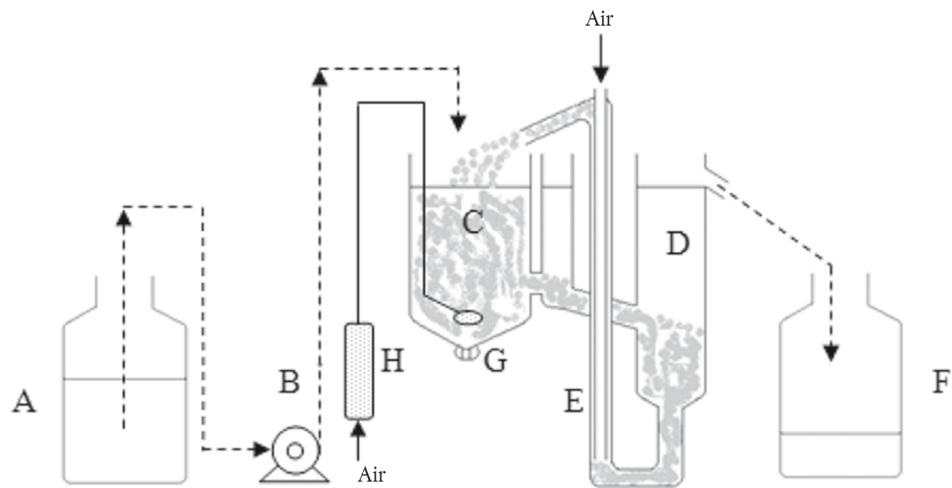
- (1) Swisher RD (1987). "Surfactant Biodegradation", 2nd Edn. Marcel Dekker Inc. New York, 1085 pp.
  - (2) German Government (1962). Ordinance of the degradability of detergents in washing and cleaning agents. Bundesgesetzblatt, Pt.1 No 49: 698-706.
  - (3) Painter HA and King EF (1978a). WRc porous-pot method for assessing biodegradability. Technical Report No 70, Water Research Centre, Medmenham, UK.
  - (4) Painter HA and King EF (1978b). The effect of phosphate and temperature on growth of activated sludge and on biodegradation of surfactants. Wat. Res. 12: 909-915.
  - (5) Eckenfelder, W.W (19) US EPA.
  - (6) Chapter C.4 of this Annex, Determination of "Ready" Biodegradability.
  - (7) Chapter C.12 of this Annex, Biodegradation — Modified SCAS Test.
  - (8) Chapter C.19 of this Annex, Estimation of the Adsorption Coefficient ( $K_{OC}$ ) on Soil and on Sewage Sludge Using High Performance Liquid Chromatography (HPLC).
  - (9) Gerike P and Fischer WK (1979). A correlation study of biodegradability determinations with various chemicals in various tests. Ecotox. Env. Saf. 3:157-173.
  - (10) Gerike P and Fischer WK (1981), as (9), II Additional results and conclusions. Ecotox. Env. Saf. 5: 45-55.
  - (11) Painter HA and Bealing D (1989). Experience and data from the OECD activated sludge simulation test. pp. 113-138, In: Laboratory tests for simulation of water treatment processes. CEC Water Pollution Report 18. Eds. Jacobsen BN, Muntau H, Angeletti G.
  - (12) ISO 11733 (1995; revised 2004). Evaluation of the elimination and biodegradability of organic substances in an aqueous medium — activated sludge simulation test.
  - (13) Birch RR (1982). The biodegradability of alcohol ethoxylates. XIII Jornado Com. Espanol. Deterg.: 33-48.
  - (14) Birch RR (1984). Biodegradation of nonionic surfactants. J.A.O.C.S. 61 (2): 340-343.
  - (15) Gerike P, Fischer WK and Holtmann W (1980). Biodegradability determinations in trickling filter units compared with the OECD confirmatory test. Wat.Res. 14: 753-758.
  - (16) Baumann U, Kuhn G and Benz M. (1998). Einfache Versuchsanordnung zur Gewinnung gewässerökologisch relevanter Daten, UWSF — Z. Umweltchem. Ökotox. 10: 214-220.
  - (17) Her Majesty's Stationery Office (1982). Assessment of biodegradability. Methods for the examination of waters and associated materials. pp. 91-98 ISBN 0117516619.
  - (18) ISO 14593 (1998). Water Quality — Evaluation in an aqueous medium of the ultimate biodegradability of organic compounds. Method by the analysis of inorganic carbon in sealed vessels.
-

## Appendix 1

Figure 1

## Equipment used for assessment of biodegradability

Husmann unit

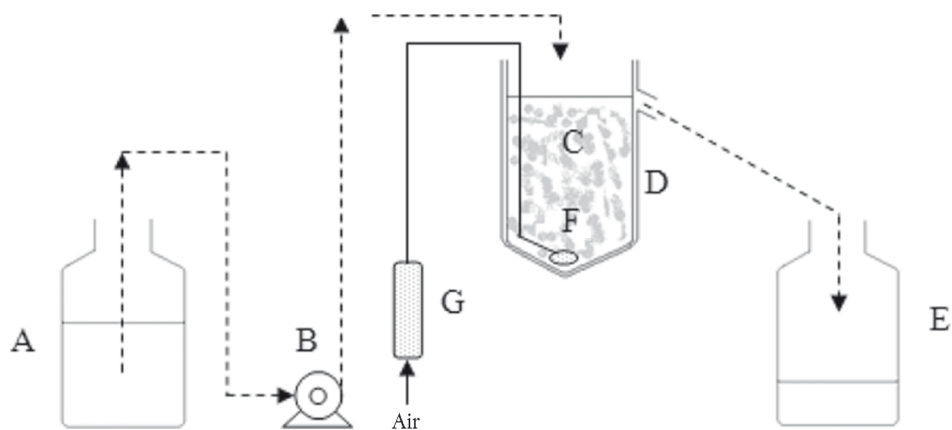


- |                                   |                      |
|-----------------------------------|----------------------|
| A. Storage vessel                 | E. Air lift pump     |
| B. Dosing pump                    | F. Collection vessel |
| C. Aeration chamber (3l capacity) | G. Aerator           |
| D. Settling vessel                | H. Air flow meter    |

Figure 2

## Equipment used for assessment of biodegradability

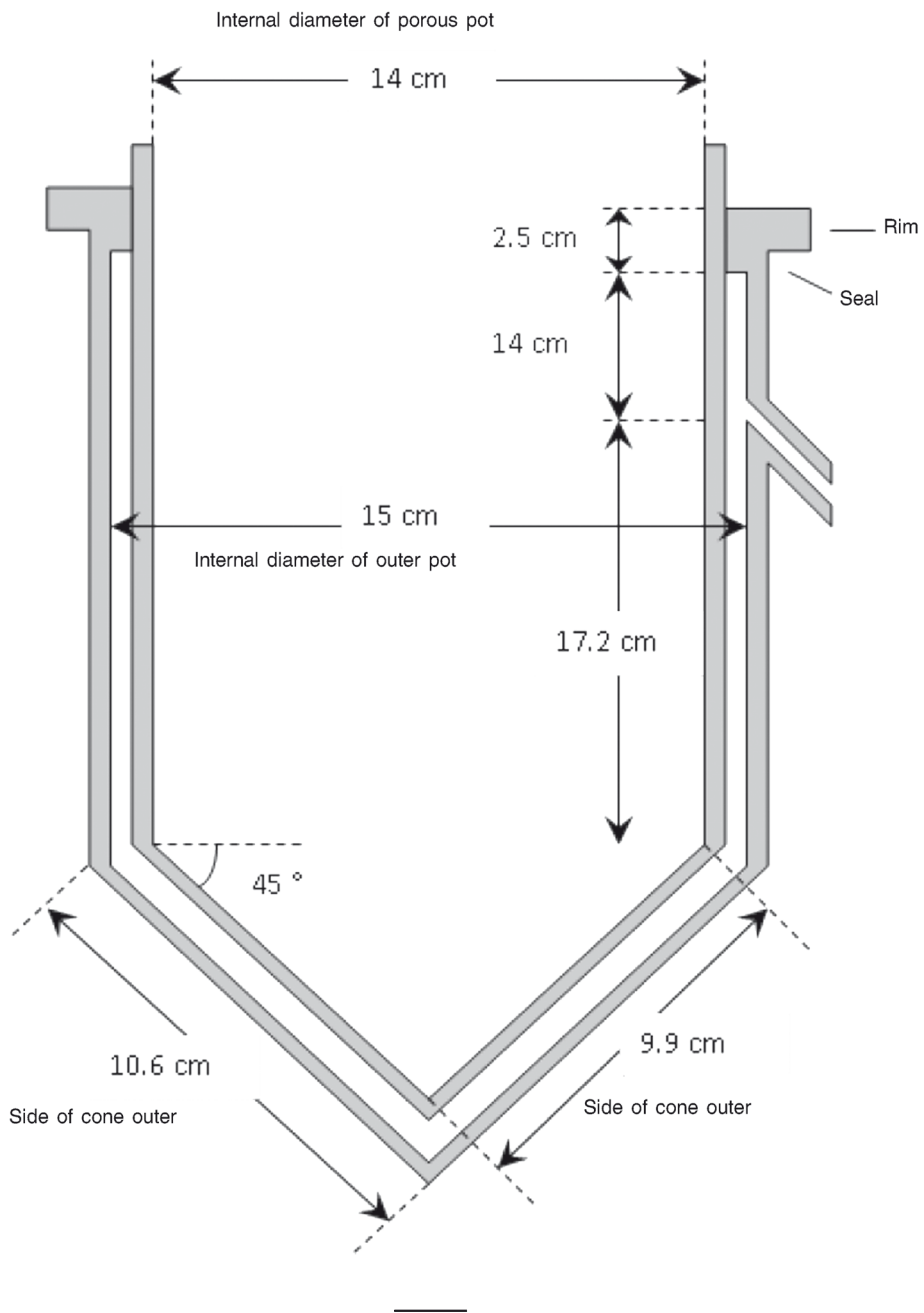
Porous pot



- |                             |                      |
|-----------------------------|----------------------|
| A. Storage vessel           | E. Collection vessel |
| B. Dosing pump              | F. Diffuser          |
| C. Porous aeration vessel   | G. Air flow meter    |
| D. Outer impermeable vessel |                      |

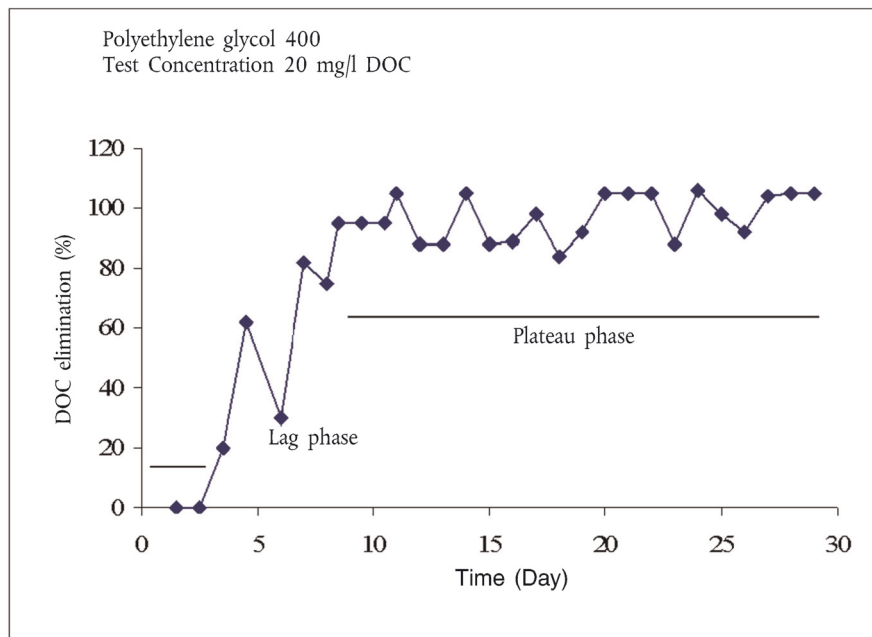
Figure 3

Details of 3 litre porous pot aeration vessel



## Appendix 2

## Example of an elimination curve





## Appendix 3

[INFORMATIVE]

## COUPLING OF THE TEST UNITS

In order to try to equalise the microbial populations in sludges in a test unit, receiving sewage plus a test chemical, and in a control unit, receiving only sewage, a daily interchange of sludge was introduced (1). The procedure was called coupling and the method is known as coupled units. Coupling was initially performed using Husmann activated sludge units but it has also been done with Porous Pot units (2)(3). No significant differences in results were found as between non-coupled and coupled units, whether Husmann or Porous Pot so there is no advantage in expending the time and energy needed in coupling the units.

Sludge exchanges can give the appearance of quite a considerable removal, since some of the test chemical is transferred and the concentrations of test chemical in the test and control effluents become more nearly equal. Thus, correcting factors have to be used, which depend on the fraction exchanged and the mean hydraulic retention time. More details of the calculation have been published (1).

Calculate the corrected DOC or COD elimination degree using the general formula:

$$D_{tc} = (D_t - 100 \cdot a \cdot r/12)/(1 - a \cdot r/12) \%$$

where

$D_{tc}$  = corrected % DOC or COD elimination

$D_t$  = determined % DOC or COD elimination

$a$  = interchange fraction of the volume of the activated sludge units

$r$  = mean hydraulic retention time (h)

If, for example, half of the volume of the aeration tank is exchanged ( $a = 0,5$ ) and the mean hydraulic retention time is 6 h, the correction formula is:

$$D_{tc} = \frac{4D_t - 100}{3}$$

## LITERATURE:

- (1) Fischer W, Gerike P, Holtmann W (1975). Biodegradability Determinations via Unspecific Analyses (Chemical Oxygen Demand, DOC) in Coupled Units of the OECD Confirmatory Test. I The test. Wat. Res. 9: 1131-1135.
- (2) Painter HA, Bealing DJ (1989). Experience and Data from the OECD Activated Sludge Simulation Test. pp. 113-138. In: Laboratory Tests for Simulation of Water Treatment Processes CEC Water Pollution Report 18. Eds. Jacobsen BN, Muntau H, Angeletti G.
- (3) Painter HA, King EF (1978). Water Research Centre Porous Pot Method for Assessing Biodegradability. Technical Report TR70, Water Research Centre, Stevenage, UK.

## Appendix 4

## EVALUATION OF INHIBITION OF THE ACTIVATED SLUDGE

**Process by test chemicals**

1. A chemical (or a waste water) may not be degraded or removed in the simulation test and may even have an inhibitory effect on the sludge micro-organisms. Other chemicals are biodegraded at low concentrations but are inhibitory at higher concentration (hormesis). Inhibitory effects may have been revealed at an earlier stage or may be determined by applying a toxicity test, using an inoculum similar to or identical with that used in the simulation test (1). Such methods are inhibition of oxygen uptake (chapter C.11 of this Annex (2) and ISO 8192(3)) or inhibition of growth of sludge organisms (ISO 15522 (4)).
2. In the simulation test any inhibition will be manifest by the difference in dissolved organic carbon (DOC) or chemical oxygen demand COD between the effluent from the test vessel and that from the control being greater than the DOC added as test chemical. Expressed in another way, the percentage removal of DOC (and biochemical oxygen demand BOD, chemical oxygen demand COD, and/or  $\text{NH}_4^+$ ) of the organic medium on treatment will be decreased by the presence of the test chemical. If this occurs, the test should be repeated reducing the concentration of the test chemical until a level is reached at which no inhibition occurs and perhaps further reducing the concentration until the test chemical is biodegraded. However, if the test chemical (or waste water) has adverse effects on the process at all concentrations tested, the indications are that the chemical is difficult, if not impossible, to treat biologically, but it may be worth repeating the test with activated sludge from a different source and/or subjecting the sludge to a more gradual acclimation.
3. Conversely, if the test chemical is bioeliminated at the first attempt in the simulation test, its concentration should be increased if it is required to be known whether the chemical could be inhibitory.
4. It should be remembered in trying to determine degrees of inhibition that the activated sludge population can change, so that with time the micro-organisms may develop a tolerance towards an inhibitory chemical.
5. Calculation of degree of inhibition:

The overall percentage removals  $R_o$ , of BOD, DOC, COD etc., for the test and control units can be calculated from:

$$R_o = 100 (I - E)/I \%$$

where:

I = influent concentration of BOD, DOC, COD etc., for test or control vessels (mg/l)  
 E = respective effluent concentrations (mg/l).

I and E must be corrected for the DOC due to the test chemical in the test units, otherwise the calculations of percentage inhibition will be incorrect.

The degree of inhibition caused by the presence of the test chemical can be calculated from:

$$\% \text{ inhibition} = 100 (R_c - R_t)/R_c$$

where:

$R_c$  = percentage removal in the control vessels  
 $R_t$  = percentage removal in the test vessels

**LITERATURE:**

- (1) Reynolds L et al. (1987). Evaluation of the toxicity of substances to be assessed for biodegradability. Chemosphere 16: 2259.
- (2) Chapter C.11 of this Annex, Biodegradation — Activated Sludge Respiration Inhibition Test.
- (3) ISO 8192 (2007) Water quality — Test for inhibition of oxygen consumption by activated sludge for carbonaceous and ammonium oxidation.
- (4) ISO 15522 (1999) Water Quality — Determination of the inhibitory effect of water constituents on activated sludge microorganisms.

## Appendix 5

**Poorly water-soluble test chemicals — volatile chemicals****Poorly water-soluble chemicals**

Few reports seem to have been published on subjecting poorly water-soluble and insoluble chemicals to tests simulating waste water treatment (1)(2)(3).

There is no single method of dispersal of the test chemical which is applicable to all insoluble chemicals. Two of the four types of method described in ISO 10634 (4) would seem to be suitable for attempting to disperse test chemicals for simulation testing; they are the use of emulsifying agents and/or of ultrasonic energy. The stability over at least 24h periods of the resulting dispersion should be established. Suitably stabilised dispersions, contained in a constantly stirred reservoir (paragraph 38), would then be dosed to the aeration tank separately from the domestic (or synthetic) sewage.

If the dispersions are stable, investigate how the test chemical can be determined in the dispersed form. It is unlikely that DOC will be suitable, so that a specific analytical method for the test chemical would have to be established which could be applied to effluents, effluent solids and activated sludge. The fate of the test chemical in the simulation of the activated sludge process would then be determined in liquid and solid phases. Thus, a "mass balance" would be established to decide whether the test chemical had been biodegraded. However, this would indicate only primary biodegradation. Demonstration of ultimate biodegradation should be attempted by applying a respirometric test for ready biodegradability (chapter C.4 of this Annex (5) C, F or D) using as inoculum sludge exposed to the test chemical in the simulation test.

**Volatile chemicals**

The application of waste water treatment simulations to volatile chemicals is both debatable and problematic. As with poorly water-soluble test chemicals, very few reports seem to have been published describing simulation tests using volatile chemicals. A conventional type of complete-mixing apparatus is adapted by sealing the aeration and settling tanks, measuring and controlling the air flow using flow-meters and passing the exit gas through traps to collect volatile organic matter. In some cases, a vacuum pump is used to draw the exit gas through a "cold" trap or a purge-trap containing Tenax and silica gel for gas-chromatographic analyses. The test chemical present in the trap can be determined analytically.

The test is carried out in two parts. The units are first operated without sludge but with the synthetic waste water plus test chemical being pumped into the aeration tank. Influent, effluent and exit gas samples are collected and analysed for the test chemical for a few days. From the data collected, the percentage ( $R_{vs}$ ) of the test chemical stripped from the system may be calculated.

Then the normal biological test (with sludge) is performed under operating conditions identical to those in the stripping study. DOC or COD measurements are also made to check that the units are performing efficiently. Occasional analyses are made to determine the test chemical in the influent, effluent and exit gas in the first part of the test; after acclimation more frequent analyses are made. Again, from the data in the steady state, the percentage of removal of the test chemical from the liquid phase by all processes ( $R_T$ ) (physical and biological) may be calculated, as well as the proportion ( $R_V$ ) stripped from the system.

Calculation:

- (a) In the non-biological test, the percentage ( $R_{VP}$ ) of the test material stripped from the system may be calculated from:

$$R_{VP} = \frac{S_{VP}}{S_{IP}} \cdot 100$$

where

$R_{VP}$  = removal of test chemical by volatilisation (%),

$S_{VP}$  = test chemical collected in trap expressed as equivalent concentration in liquid phase (mg/l),

$S_{IP}$  = test chemical concentration in influent (mg/l).

- (b) In the biological test, the percentage ( $R_V$ ) of the test material stripped from the system may be calculated from:

$$R_V = \frac{S_V}{S_I} \cdot 100$$

where

$R_V$  = removal of test chemical by volatilisation in biological test (%),

$S_V$  = test chemical collected in trap in biological test, expressed as equivalent concentration in liquid influent (mg/l),

$S_I$  = test chemical concentration in influent (mg/l).

(c) In the biological test, the percentage ( $R_T$ ) of the test chemical removed by all processes is given by:

$$R_T = 1 - \frac{S_E}{S_I} \cdot 100$$

where

$S_E$  = concentration of test chemical in the (liquid) effluent (mg/l).

(d) Thus, the percentage ( $R_{BA}$ ) removed by biodegradation plus adsorption can be calculated from:

$$R_{BA} = (R_T - R_V)$$

Separate tests should be carried out to determine whether the test chemical is adsorbed; if it is, then a further correction may be made.

(e) A comparison between the proportion of test chemical stripped from the biological ( $R_V$ ) and non-biological test ( $R_{VP}$ ) systems indicates the overall effect that biological treatment has had on the emission of the test chemical into the atmosphere.

*Example:* Benzene

Sludge retention time = 4 days

A synthetic sewage; retention time = 8 h.

$$S_{IP} = S_I = 150 \text{ mg/l}$$

$$S_{VP} = 150 \text{ mg/l} \quad (S_{EP} = 0)$$

$$S_V = 22,5 \text{ mg/l}$$

$$S_E = 50 \text{ } \mu\text{g/l}$$

Thus,

$$R_{VP} = 100, \quad R_V = 15$$

$$R_T = 100 \text{ and } R_{BA} = 85.$$

Benzene was assumed not to be adsorbed onto sludge.

#### LITERATURE:

- (1) Horn JA, Moyer JE, Hale JH (1970). Biological degradation of tertiary butyl alcohol. Proc. 25th Ind. Wastes Conference Purdue Univ.: 939-854.
- (2) Pitter P, Chudoba J (1990). Biodegradability of organic substances in the aquatic environment. CRC Press. Boston, USA.
- (3) Stover EL, Kincannon DF (1983). Biological treatability of specific organic compounds found in chemical industry waste waters. J. Wat. Pollut. Control Fed. 55: 97.
- (4) ISO 10634 (1995) Water Quality — Guidance for the preparation and treatment of poorly water-soluble organic compounds for the subsequent evaluation of their biodegradability in an aqueous medium.
- (5) Chapter C.4 of this Annex, Determination of "Ready" Biodegradability.

## Appendix 6

**Effects of sludge retention time (SRT) on treatability of chemicals**

## INTRODUCTION

1. The method described in the main text was designed to ascertain whether the chemicals tested (usually those known to be inherently, but not readily, biodegradable) can be biodegraded within the limits imposed in waste water treatment plants. The results are expressed in terms of percentage removal and percentage biodegradation. The conditions of operation of the activated sludge units and choice of influent allow rather wide variations in concentration of the test chemical in the effluent. Tests are carried out at only one nominal concentration of sludge solids or one nominal sludge retention time (SRT) and the sludge wastage regimes described can cause the value of SRT to vary considerably during the test, both from day to day and during a day.
2. In this variant (1)(2) the SRT is controlled within much narrower limits throughout each 24h period (just as happens on the large-scale) which results in a more constant concentration in effluents. Domestic sewage is recommended since it gives more consistent and higher percentage removals. Also, the effects of a number of SRT values are investigated and in a more detailed study the effects of a range of temperatures on effluent concentration may be determined.
3. There is no general agreement yet on which kinetic models operate when chemicals bio-degrade under conditions in waste water treatment. The Monod model of bacterial growth and substrate utilisation was chosen (1)(2) to be applied to the data collected, since the method was intended to be applied only to chemicals produced in high tonnages, resulting in concentrations in sewage of above 1 mg/l. The validity of the simplified model and the assumptions made was established using a series of alcohol ethoxylates having varying degrees of primary biodegradability (2)(3).

*Note:* This variant method follows closely much of the text of this test method C.10-A and only those details which differ are given hereafter.

## PRINCIPLE OF THE TEST

4. Activated sludge porous-pot units, designed to facilitate the (almost) continuous wastage of mixed liquor allowing very precise control of the sludge retention time (SRT, or  $\theta_c$ ), are operated in the non-coupled mode over a range of SRTs and, optionally, over a range of temperatures. The retention time is usually 2 to 10 days and the temperature between 5 and 20 °C. Sewage, preferably domestic, and a solution of the test chemical are dosed separately to the units at rates to give the required sewage retention time (3 to 6 hours) and the required concentration of test chemical in the influent. Control units receiving no test chemical are operated in parallel for comparative purposes.
5. Other types of apparatus can be used but great care should be exercised to ensure that good control of SRT is achieved. For example, when using plants, which incorporate a settler, allowance for loss of solids via the plant effluent may be necessary. Further, special precautions to avoid errors due to variation in the quantity of sludge in the settler should also be taken.
6. The units are operated at each selected set of conditions and, after equilibrium has been reached, the average steady state concentrations in the effluents of test chemical and, optionally, DOC are obtained over a period of about three weeks. Besides assessing the percentage removal of test chemical and, optionally, DOC, the relationship between plant-operating conditions and the concentration in the effluent is expressed in graphical form. From this tentative kinetic constants may be calculated and the conditions under which the test chemical can be treated may be predicted.

## INFORMATION ON THE TEST CHEMICAL

7. Chapter C.10 A, paragraphs 12 and 13 apply.

## PASS LEVELS

8. Chapter C.10 A, paragraphs 14 and 15 apply.

## REFERENCE TEST CHEMICAL

9. Chapter C.10 A, paragraph 16 applies.

## REPRODUCIBILITY OF TEST RESULTS

10. Chapter C.10 A, paragraphs 17 and 18 apply.

## DESCRIPTION OF THE METHOD

**Apparatus**

11. A suitable unit is the modified porous pot system (Appendix 6.1). It consists of an inner vessel (or liner) constructed from porous polypropylene of 3,2 mm thickness and pore size of approximately 90 µm, the joint being butt-welded. (This makes a more robust unit than that described in paragraph 21 of this chapter, C.10 A). The liner is fitted into an impervious polyethylene outer vessel, which consists of two parts: a circular base in which holes are bored to accommodate two air lines and a sludge-wastage line, and an upper cylinder which screws on to the base and which has an outlet placed so as to give a known volume (3 l) in the porous pot vessel. One of the air lines is fitted with a diffuser stone and the other is open-ended and set at right-angles to the stone in the pot. This system produces the necessary turbulence to ensure that the contents of the pot are completely mixed, as well as providing concentrations of dissolved oxygen greater than 2 mg/l.
12. The appropriate number of units are maintained at controlled temperatures in the range of 5 to 20 °C ( $\pm 1$  °C), either in water baths or in constant temperature rooms. Pumps are required to dose to the aeration vessels the solution of the test chemical and settled sewage at the required rates (0-1,0 ml/min and 0-25 ml/min, respectively) and a third pump to remove waste sludge from the aeration vessels. The necessary very low flow-rate of waste sludge is achieved by using a pump set at a higher rate and operated intermittently by the use of a timer-switch, e.g. operating for 10 seconds per min, pump delivery rate of 3ml/min yielding a wastage rate of 0,5 ml/min.

*Filtration apparatus or centrifuge*

13. Chapter C10 A, paragraph 23 applies.

*Analytical equipment*

14. Chapter C.10 A, paragraph 24 applies.

*Water*

15. Chapter C.10 A, paragraphs 25 and 26 apply.

*Organic medium*

16. Chapter C.10 A, paragraph 27 applies.

*Synthetic sewage*

17. Chapter C.10 A, paragraph 28 applies.

*Domestic sewage*

18. Chapter C.10 A, paragraph 29 applies.

*Activated sludge*

19. Chapter C10 A, paragraph 30 applies.

*Stock solutions of test chemical*

20. Chapter C.10 A, paragraphs 31 and 32 apply.

## PROCEDURE

*Preparation of the inoculum*

21. Chapter C.10 A, paragraph 34 applies only — use activated sludge (about 2,5 g/l).

*Number of test units*

22. For a simple test, ie. to measure percentage removal, only a single SRT is required, but in order to acquire data necessary to calculate tentative kinetic constants 4 or 5 SRT values are required. Values between 2 and 10 days are usually chosen. Practically, it is convenient to perform a test at 4 or 5 SRTs simultaneously at one temperature; in extended studies the same SRT values, or perhaps a different range of values, are used at other temperatures within

the range 5 to 20 °C. For primary biodegradation (the main use), only one unit per set of conditions is normally required. However, for ultimate biodegradability a control unit is required, for each set of conditions, which receives sewage but not test chemical. If the test chemical is thought to be present in the sewage used, it would be necessary to use control units when assessing primary biodegradation, and making the necessary correction in the calculations.

#### *Dosage of organic medium and test chemical*

23. Chapter C.10 A, paragraphs 36 to 39 apply, but note that the test chemical solution is dosed separately and that various sludge wastage rates are used. Also monitor and adjust, if necessary, to within  $\pm 10\%$ , the flow-rates of influents, effluents and sludge wastage frequently, e.g. twice per day. If difficulties are encountered in the analytical methods when domestic sewage is used, carry out the test with synthetic sewage, but it must be assured that different media give comparable kinetic data.

#### *Handling of activated sludge units*

24. Chapter C.10 A, paragraphs 40 to 43 apply, but control SRT only by "constant" wastage of sludge.

#### *Sampling and analysis*

25. Chapter C.10 A, paragraphs 44 to 50 apply, except that the concentration of the test chemical is to be determined and DOC determined optionally; COD should not be used.

### DATA AND REPORTING

#### **Treatment of results**

26. Chapter C.10 A, paragraphs 52 to 54 apply.

#### **Expression of test results**

27. Chapter C.10 A, paragraphs 56 to 62 apply.

#### **Calculation of kinetic constants**

28. It is more realistic to quote the mean steady — state concentration of the test chemical in the effluent and to describe how this varies with plant-operating conditions than to quote percentage primary biodegradation. This can be done by consideration of equation (6) in Appendix 6.2, which can yield values for  $K_S$ ,  $\mu_m$  and  $\vartheta_{SC}$ , the critical sludge retention time.

(Alternatively, approximate values of  $K_S$  and  $\mu_m$  may be obtained using a simple computer program to fit the theoretical curve calculated from equation 2 (Appendix 6.2) to the experimental values obtained. Although any given solution will not be unique, a reasonable approximation of  $K_S$  and  $\mu_m$  can be obtained.)

#### **Variability of results**

29. It is common experience that variable values of kinetic parameters for individual chemicals are obtained. It is thought that the conditions under which the sludge has been grown, as well as the conditions prevailing in the test used (as in paragraph 5 and in other tests), have a large effect on the resulting values. One aspect of this variability has been discussed by Grady et al (4), who have suggested that the terms "extant" and "intrinsic" should be applied to two extreme conditions representing the limits of physiological state a culture may attain during a kinetic experiment. If the state is not allowed to change during the test, the kinetic parameter values reflect the conditions in the environment from which the micro-organisms were taken; these values are called "extant" or currently existing. At the other extreme, if conditions in the test are such as to permit the full development of the protein-synthesizing system allowing maximum possible growth rate, the kinetic parameters obtained are said to be "intrinsic", and are dependent only on the nature of the substrate and the types of bacteria in the culture. As a guide, extant values will be obtained by keeping the ratio of concentration of substrate to competent micro-organisms ( $S_0/X_0$ ) low, e.g. 0,025, and intrinsic values arise when the ratio is high e.g. at least 20. In both cases,  $S_0$  should equal or exceed the relevant value of  $K_S$ , the half-saturation constant.
30. Variability and other facets of biodegradation kinetics were discussed at a recent SETAC workshop (5). From such studies, reported and projected, a clearer view of kinetics operating in waste water treatment plants should be forthcoming to enable a better interpretation of existing data to be made, as well as to suggest more relevant designs for future Test Methods.

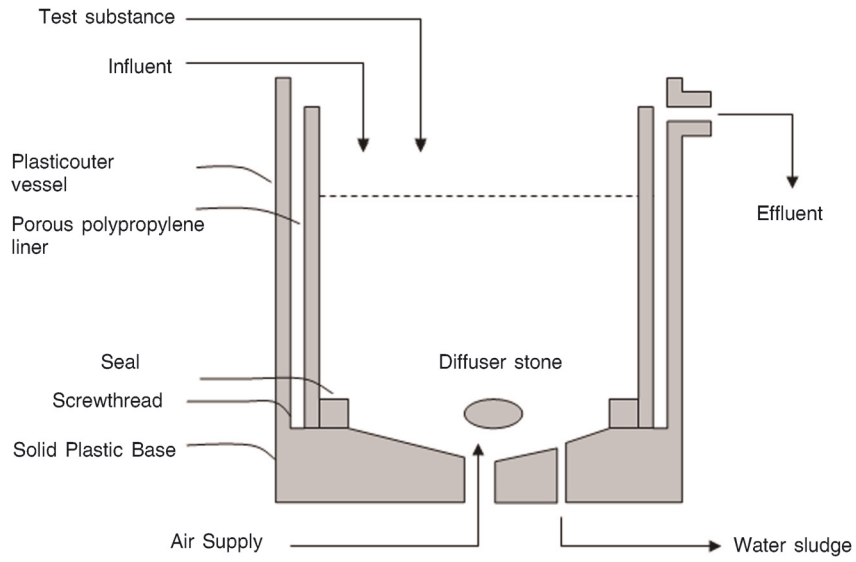
*LITERATURE:*

- (1) Birch RR (1982). The biodegradability of alcohol ethoxylates. XIII Jornado Com. Espanol Deterg.: 33-48.
  - (2) Birch RR (1984). Biodegradation of nonionic surfactants. J.A.O.C.S., 61(2): 340-343.
  - (3) Birch RR (1991). Prediction of the fate of detergent chemicals during sewage treatment. J. Chem. Tech. Biotechnol., 50: 411-422.
  - (4) Grady CPL, Smets BF and Barbeau DS (1996). Variability in kinetic parameter estimates: A review of possible causes and a proposed terminology. Wat. Res., 30 (3): 742-748.
  - (5) Biodegradation kinetics: Generation and use of data for regulatory decision making (1997). Workshop at Port Sunlight, UK. Eds. Hales SG, Feitjel T, King H, Fox K, Verstraete W. 4-6th Sept. 1996. SETAC- Europe, Brussels.
-



Appendix 6.1

**Porous Pot with SRT Control**



## Appendix 6.2

## Calculation of Kinetic Constants

1. By assuming Monod kinetics apply and considering a mass balance of active solids and substrate across the activated sludge system (1), the following steady state expressions can be obtained:

$$\frac{1}{\vartheta_s} = \frac{\mu_m \cdot S_1}{K_s + S_1} - K_d \quad [1]$$

or

$$S_1 = \frac{K_s \cdot (1 + K_d \cdot \vartheta_s)}{\vartheta_s \cdot (\mu_m - K_d) - 1} \quad [2]$$

where:

$S_1$  = concentration of substrate in effluent, (mg/l)

$K_s$  = half-saturation constant, the concentration at which  $\mu = \mu_m/2$  (mg/l)

$\mu$  = specific growth rate ( $d^{-1}$ )

$\mu_m$  = maximum value of  $\mu_m$  ( $d^{-1}$ )

$K_d$  = specific decay rate of active solids ( $d^{-1}$ )

$\vartheta_s$  = sludge mean retention time, SRT (d)

Examination of this equation leads to the following conclusions:

- (i) The effluent concentration is independent of that in the influent ( $S_0$ ); hence, the percentage biodegradation varies with the influent concentration,  $S_0$ .
- (ii) The only plant-control parameter affecting  $S_1$  is the sludge retention time,  $\vartheta_s$ .
- (iii) For a given concentration in the influent,  $S_0$ , there will be a critical sludge retention time, such that:

$$\frac{1}{\vartheta_{SC}} = \frac{\mu_s \cdot S_0}{K_s + S_0} - K_d \quad [3]$$

where:

$\vartheta_{SC}$  = critical sludge retention time, below which the competent micro-organisms will be washed out of the plant.

- (iv) Since the other parameters in equation (2) are associated with growth kinetics, temperature is likely to affect the effluent substrate level and the critical sludge age, ie. the sludge retention time needed to obtain a certain degree of treatment would increase with decreasing temperature.

2. From a mass balance of solids in the porous pot system, and assuming that the solids concentration in the plant effluent,  $X_2$  is low compared with that in the aeration vessel,  $X_1$ , the sludge retention time

$$\vartheta_s = \frac{V \cdot X_1}{(Q_0 - Q_1) \cdot X_2 + Q_1 \cdot X_1} \quad [4]$$

and

$$\vartheta_s = \frac{V \cdot X_1}{Q_1 \cdot X_1} = \frac{V}{Q_1}$$

where:

$V$  = volume of the aeration vessel (l)

$X_1$  = concentration of solids in aeration vessel (mg/l)

$X_2$  = concentration of solids in effluent (mg/l)

$Q_0$  = flow rate of influent (l/d)

$Q_1$  = flow rate of waste sludge (l/d)

Thus, it is possible to control the sludge retention time at any pre-selected value by the control of the waste sludge flow rate,  $Q_1$ .

Conclusions:

- The main purpose of the test is thus to allow the effluent concentration, and hence the levels of test chemical in the receiving waters, to be predicted.
- By plotting  $S_1$ , vs.  $\vartheta_s$ , the critical sludge retention time,  $\vartheta_{SC}$ , can sometimes be readily evaluated, eg. curve 3 in Figure 1. When this is not possible,  $\vartheta_{SC}$  may be calculated, together with approximate values of  $\mu_m$  and  $K_S$ , by plotting  $S_1$ , vs.  $S_1 \cdot \vartheta_s$ .

Rearrangement of equation (1) gives

$$\frac{S_1 \cdot \vartheta_s}{1 + \vartheta_s \cdot K_d} = \frac{K_s}{\mu_m} + \frac{S_1}{\mu_m} \quad [5]$$

If  $K_d$  is small, then  $1 + \vartheta_s \cdot K_d \sim 1$  and [5] becomes:

$$S_1 \cdot \vartheta_s = \frac{K_s}{\mu_m} + \frac{S_1}{\mu_m} \quad [6]$$

Thus, the plot should be a straight line (see Figure 2) of slope  $1/\mu_m$  and intercept  $K_s/\mu_m$ ; also  $\vartheta_s \sim 1/\mu_m$ .

Figure 1

**Three temperatures; five SRTs**

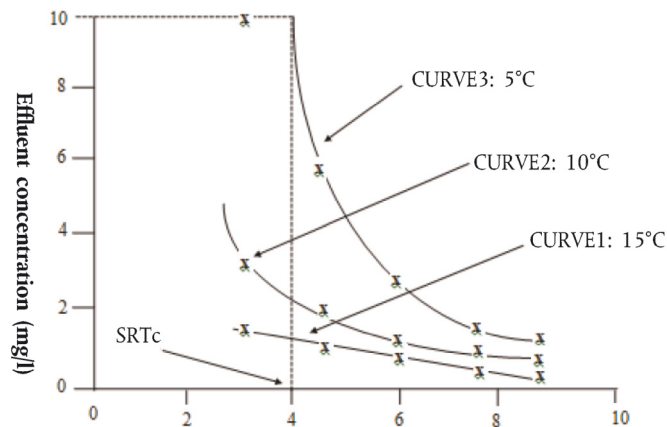
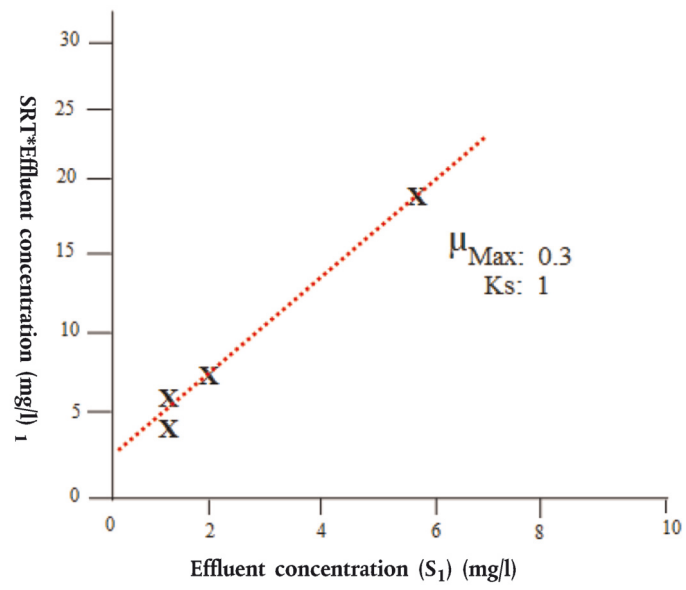


Figure 2

Regression Line  $SRT \cdot S_1$  vs  $S_1$  at  $T = 5^\circ\text{C}$ 

Glossary:

Effluent concentration:

Curve:

—

## Appendix 7

TEST AT LOW ( $\mu\text{g/l}$ ) CONCENTRATION RANGE

1. Many chemicals are normally present in the aquatic environment, even in waste waters, at very low concentrations ( $\mu\text{g/l}$ ). At such concentrations, they probably do not serve as primary substrates resulting in growth, but are more likely to degrade as non-growth, secondary substrates, concurrent with a variety of naturally occurring carbon chemicals. Consequently the degradations of such chemicals will not fit the model described in Appendix 6. There are many models which could be applied and, under the conditions prevailing in waste water treatment systems, more than one may be simultaneously operative. Far more research will be necessary to elucidate this problem.
2. Meanwhile the procedure given in the main text (chapter C.10 A) can be followed, but only for primary biodegradability, using suitably low concentrations ( $< 100 \mu\text{g/l}$ ) and a validated analytical procedure. The percentage biodegradation may be calculated (see para. 54 of the Test Method) provided that abiotic processes (adsorption, volatility, etc.) are taken into account. An example is the study by Nyholm and his associates (1)(2) using a 4 h cycle in a fill and draw system. They reported pseudo first-order constants for 5 chemicals added in a synthetic sewage at 5 to 100  $\mu\text{g/l}$ . (For ultimate biodegradability  $^{14}\text{C}$ -labelled test chemicals may be used. A description of this is beyond the scope of this Test Method since there are as yet no agreed procedures, though a proposed method for ISO 14592 (3) contains guidance on the use of  $^{14}\text{C}$ -labelled chemicals.

**SCAS test**

3. Later, a simpler two-stage test was proposed (4)(5)(6); the semi-continuous activated sludge (SCAS) method is followed by short-term kinetic tests on samples withdrawn from the SCAS units. The SCAS system is operated with known sludge wastage rates (unlike the original C.12 test method) and is fed a modified OECD synthetic sewage or domestic sewage. The synthetic sewage was modified (because of changing pH value and poor sludge settleability) by addition of phosphate as buffer, yeast extract, iron (III) chloride and trace element salts, and its COD was increased to about 750  $\text{mg/l}$  by increasing the concentration of peptone and meat extract. The units were operated on a 24 h cycle: aeration for 23 h, wastage of sludge, settlement, withdrawal of supernatant (effluent) followed by addition of synthetic sewage plus test chemical, up to 100  $\mu\text{g/l}$ , (i.e. at about the same concentration used in the short term test). Once per week 10 % of the total sludge was replaced by fresh sludge in order to maintain a balanced microbial population.
4. The concentrations of test chemical initially and at the end of aeration are measured and the test is continued until a constant removal of test chemical is attained; this takes from one week to several months.

**Short-term test**

5. A short test (e.g. 8 hours) is applied to determine the (pseudo) first order kinetic rate constant for the decay of the test chemical in activated sludge of known but different origins and histories. In particular, sludge samples are taken from the SCAS reactors — at the end of an aeration period when the concentration of organic substrate is low — during the course of an acclimatisation experiment (paragraphs 3, 4). Sludge may also be taken from a parallel SCAS unit not exposed to the test chemical, for comparison. Mixtures of sludge and the test chemical added at two or more concentrations in the range 1-50  $\mu\text{g/l}$  are aerated, without the addition of synthetic sewage or other organic substrate. The test chemical remaining in solution is determined at regular intervals e.g. hourly depending on the degradability of the chemical, for a period not longer than 24h. Samples are centrifuged before appropriate analysis.

**Calculations**

6. Data from the SCAS units are used to calculate the percentage removal of test chemical (paragraph 54). Also, an average rate constant,  $K_1$ , (normalised for concentration of suspended solids) can be calculated from:

$$K_1 = 1/t \cdot \ln \frac{C_e}{C_i} \cdot 1/SS (\text{1/g h})$$

where:

$t$  = aeration time (23h)

$C_e$  = concentration at end of aeration period ( $\mu\text{g/l}$ )

$C_i$  = concentration at beginning of aeration ( $\mu\text{g/l}$ )

$SS$  = concentration of activated sludge solids ( $\text{g/l}$ )

7. In the short term test the log % concentration remaining is plotted against time and the slope of the initial part (10-50 % degradation) of the plot is equivalent to  $K_1$ , the (pseudo) first order constant. The constant is normalised with respect to the concentration of sludge solids by dividing the slope by the concentration of sludge solids. The reported result must also include details of initial concentrations of the test chemical and suspended solids, sludge retention time, sludge loading and source, and details of pre-exposure (if any) to the test chemical.

### Variability of results

8. Variability and other facets of biodegradation kinetics were discussed at a recent SETAC workshop (7). From such studies, reported and projected, a clearer view of kinetics operating in waste water treatment plants should be forthcoming to enable a better interpretation of existing data to be made, as well as to suggest more relevant designs for future Test Methods.

### LITERATURE:

- (1) Nyholm N, Jacobsen BN, Pedersen BM, Poulsen O, Dambourg A and Schultz B (1992). Removal of micropollutants in laboratory activated sludge reactors. *Biodegradability. Wat. Res.* 26: 339-353.
- (2) Jacobsen BN, Nyholm N, Pedersen BM, Poulsen O, and Ostfeldt P (1993). Removal of organic micropollutants in laboratory activated sludge reactors under various operating conditions: Sorption. *Wat. Res.* 27: 1505-1510.
- (3) ISO 14592 (ISO/TC 147/SC5/WG4, N264) (1998). Water Quality — Evaluation of the aerobic biodegradability of organic compounds at low concentrations in water.
- (4) Nyholm N, Ingerslev F, Berg UT, Pedersen JP and Frimer-Larsen H (1996). Estimation of kinetic rate constants for biodegradation of chemicals in activated sludge waste water treatment plants using short-term batch experiments and µg/l range spiked concentrations *Chemosphere* 33 (5): 851-864.
- (5) Berg UT and Nyholm N (1996). Biodegradability simulation Studies in semi-continuous activated sludge reactors with low (µg/l range) and standard (ppm range) chemical concentrations. *Chemosphere* 33 (4): 711-735.
- (6) Danish Environmental Protection Agency. (1996). Activated sludge biodegradability simulation test. Environmental Project, No 337. Nyholm, N. Berg, UT. Ingerslev, F. Min. of Env. and Energy, Copenhagen.
- (7) Biodegradation kinetics: Generation and use of data for regulatory decision making (1997). Workshop at Port Sunlight, UK. Eds. Hales, SG. Feitjel, T. King, H. Fox, K. and Verstraete, W. 4-6th Sept. 1996. SETAC- Europe, Brussels.

---

### C.10-B: Biofilms

#### INTRODUCTION

1. Simulation tests are normally applied to chemicals which have failed a screening test for ready biodegradability (Chapter C.4 A to F of this Annex (9)), but have passed a test for inherent biodegradability. Exceptionally simulation tests are also applied to any chemical about which more information is required, especially high-tonnage chemicals, and normally the activated sludge test is applied (C.10 A). In some circumstances, however, specific information is required relating the behaviour of a chemical to methods of waste water treatment involving biofilms, namely, percolating or trickling filters, rotating biological contactors, fluidised beds. To meet this need various devices have been developed.
2. Gerike *et al.* (1) used large, pilot-scale trickling filters which they used in the coupled mode. These filters took up much space and required relatively large volumes of sewage or synthetic sewage. Truesdale *et al.* (2) described smaller filters (6 ft × 6 in. diameter) which were fed surfactant-free natural sewage but still required rather large volumes. As many as 14 weeks were required for the development of a "mature" biofilm and an additional 4-8 weeks were needed after first introduction of the test surfactant before acclimatisation took place.
3. Baumann *et al.* (3) developed a much smaller filter which used polyester "fleece" previously steeped in activated sludge as the inert medium supporting the biofilm. The test chemical was used as the sole source of carbon and biodegradability was assessed from measurements of dissolved organic carbon (DOC) in the influent and effluent, and from the amount of CO<sub>2</sub> in the exit gas.
4. A quite different approach was made by Gloyna *et al.* (4) who invented the rotating tubular reactor. On the internal surface of the rotating tube a biofilm was grown on the known surface area by passage of influent introduced at the top end of the tube, inclined at a small angle to the horizontal. The reactor has been used to study the biodegradability of surfactants (5), as well as to investigate the optimal thickness of biofilm and diffusion through the film (6). These latter authors further developed the reactor, including modifying it to be able to determine CO<sub>2</sub> in the exit gas.

5. The rotating tubular reactor has been adopted by the Standing Committee of Analysts (UK) as a standard method for assessing both the biodegradability of chemicals (7) and the treatability and toxicity of waste waters (8). The method described here has the advantages of simplicity, compactness, reproducibility and the need for relatively small volumes of organic medium.

#### PRINCIPLE OF THE TEST

6. Synthetic or domestic sewage, and the test chemical, in admixture or alone, are applied to the internal surface of a slowly rotating inclined tube. A layer of microorganisms, similar to those present on bio-filter media, is built up on the internal surface. The conditions of operation of the reactor are chosen to give adequate elimination of organic matter and, if required, oxidation of ammonium.
7. Effluent from the tube is collected and either settled and/or filtered before analysis for dissolved organic carbon (DOC) and/or the test chemical by a specific method. Control units receiving no test chemical are operated in parallel under the same conditions for comparative purposes. The difference between the concentrations of DOC in the effluent from the test and control units is assumed to be due to the test chemical and its organic metabolites. This difference is compared with the concentration of the added test chemical (as DOC) to calculate the elimination of the test chemical.
8. Biodegradation may normally be distinguished from bio-adsorption by careful examination of the elimination-time curve. Confirmation may usually be obtained by applying a test for ready biodegradation (oxygen uptake or carbon dioxide production) using an acclimated inoculum taken at the end of the test from the reactors receiving the test chemical.

#### INFORMATION ON THE TEST CHEMICAL

9. The purity, water solubility, volatile and adsorption characteristics of the test chemical should be known to enable correct interpretation of results to be made.
10. Normally, volatile and poorly soluble chemicals cannot be tested unless special precautions are taken (see Appendix 5 to chapter C.10 A). The chemical structure, or at least the empirical formula, should also be known in order to calculate theoretical values and/or to check measured values of parameters, e.g. theoretical oxygen demand (ThOD), DOC.
11. Information on the toxicity of the test chemical to micro-organisms (see Appendix 4 to chapter C.10 A) may be useful for selecting appropriate test concentrations and may be essential for the correct interpretation of low biodegradation values.

#### PASS LEVELS

12. Originally, the primary biodegradation of surfactants was required to reach 80 % or more before the chemical could be marketed. If the value of 80 % is not attained, this simulation (confirmatory) test may be applied and the surfactant may be marketed only if more than 90 % of the specific chemical is removed. With chemicals in general there is no question of a pass/fail level and the value of percentage removed can be used in proximate calculations of the probable environmental concentration to be used in hazard assessments posed by chemicals. In a number of studies of pure chemicals the percentage removal of DOC was found to be > 90 % in more than three-quarters, and > 80 % in over 90 %, of chemicals which showed any significant degree of biodegradability.

#### REFERENCE CHEMICALS

13. To ensure that the experimental procedure is being carried out correctly, it is useful occasionally to test reference chemicals whose behaviour is known. Such chemicals include adipic acid, 2-phenyl phenol, 1-naphthol, diphenic acid and 1-naphthoic acid.

#### REPRODUCIBILITY OF TEST RESULTS

14. The relative standard deviation within tests was found by a laboratory in the UK to be 3,5 % and between tests to be 5 % (7).

#### DESCRIPTION OF THE METHOD

##### **Apparatus**

##### *Rotating tubular reactors*

15. The apparatus (see figures 1 and 2 in the Appendix 8 consists of a bank of acrylic tubes each 30,5 cm long and 5 cm internal diameter, supported on rubber-rimmed wheels contained within a metal supporting frame. Each

tube has an outside lip, approximately 0,5 cm deep, to retain it on the wheels, the internal surface is roughened with coarse wire wool and there is a 0,5 cm deep internal lip at the upper (feed) end to retain the liquid. The tubes are inclined at an angle of approximately one degree to the horizontal to achieve the required contact time when the test medium is applied to a clean tube. The rubber-tyred wheels are rotated using a slow, variable-speed motor. The temperature of the tubes is controlled by installation in a constant temperature room.

16. By enclosing each tube reactor inside a slightly larger, capped tube and ensuring that connections were gas-tight, exit CO<sub>2</sub> gas could be collected in an alkaline solution for subsequent measurement (6).
17. A 24h supply, for each tube, of organic medium with added test chemical if applicable, is contained in a 20 l storage vessel (A)(see Figure 2). If required, the test chemical solution may be dosed separately. Near the bottom of each storage vessel there is an outlet which is connected by suitable tubing, e.g. silicone rubber, via a peristaltic pump (B) to a glass or acrylic delivery tube which enters 2-4 cm into the higher (feed) end of the inclined tube (C). Effluent is allowed to drip from the lower end of the inclined tube to be collected in another storage vessel (D). The effluent is settled or filtered before analysis.

#### *Filtration apparatus-centrifuge*

18. Device for filtration of samples with membranes filter of suitable porosity (nominal aperture diameter 0,45 µm) which adsorb organic chemicals or release organic carbon to a minimum degree. If filters are used which release organic carbon, wash them carefully with hot water to remove leachable organic carbon. Alternatively a centrifuge capable of achieving 40 000 m/sec<sup>2</sup> may be used.
19. Analytical equipment for determining:
  - DOC/total organic carbon (TOC), or chemical oxygen demand (COD);
  - specific chemical (HPLC, GC etc.) if required;
  - pH, temperature, acidity, alkalinity;
  - ammonium, nitrite, nitrate, if the tests are performed under nitrifying conditions.

#### *Water*

20. Tap water, containing less than 3 mg/l DOC.
21. Distilled or deionised water, containing less than 2 mg/l DOC.

#### *Organic medium*

22. Synthetic sewage, domestic sewage or a mixture of both may be used as the organic medium. It has been shown that the use of domestic sewage alone often gives increased percentage removed of DOC (in activated sludge units) and even allows the biodegradation of some chemicals, which are not biodegraded when OECD synthetic sewage is used. Thus, the use of domestic sewage is recommended. Measure the DOC (or COD) concentration in each new batch of organic medium. The acidity or alkalinity of the organic medium should be known. The medium may require the addition of a suitable buffer (sodium hydrogen carbonate or potassium hydrogen phosphate), if it is of low acidity or alkalinity, to maintain a pH of about 7,5 ± 0,5 in the reactor during the test. The amount of buffer, and when to add it, has to be decided in each individual case.

#### *Synthetic sewage*

23. Dissolve in each 1 litre of tap water: peptone, 160 mg; meat extract, 110 mg; urea, 30 mg; anhydrous dipotassium hydrogen phosphate, (K<sub>2</sub>HPO<sub>4</sub>), 28 mg; sodium chloride, (NaCl), 7 mg; calcium chloride dihydrate, (CaCl<sub>2</sub>·2H<sub>2</sub>O), 4 mg; magnesium sulphate heptahydrate, (MgSO<sub>4</sub>·7H<sub>2</sub>O), 2 mg. This OECD synthetic sewage is an example and gives a mean DOC concentration in the influent of about 100 mg/l. Alternatively, use other compositions, with about the same DOC concentrations, which are closer to real sewage. This synthetic sewage may be made up in distilled water in a concentrated form and stored at about 1 °C for up to one week. When needed, dilute with tap water. (This medium is unsatisfactory e.g. nitrogen concentration is very high, relatively low carbon content, but nothing better has been suggested, except to add more phosphate, as buffer, and extra peptone).



*Domestic sewage*

24. Use fresh settled sewage collected daily from a treatment works receiving predominantly domestic sewage. It should be collected from the overflow channel of the primary sedimentation tank, or from the feed to activated sludge plant, and be largely free from coarse particles. The sewage can be used after storage for several days at about 4 °C, if it is proved that the DOC (or COD) has not significantly decreased (i.e. by less than 20 %) during storage. In order to limit disturbances to the system, the DOC (or COD) of each new batch should be adjusted before use to an appropriate constant value, e.g. by dilution with tap water.

*Lubricant*

25. Glycerol or olive oil may be used for lubricating the peristaltic pump rollers: both are suitable for use on silicone-rubber tubing.

*Stocks solutions of test chemical*

26. For chemicals of adequate solubility prepare stock solutions at appropriate concentrations (e.g. 1 to 5 g/l) in deionised water or in the mineral portion of the synthetic sewage. For insoluble chemicals, see Appendix 5 in chapter C.10-A. This method is not suitable for volatile chemicals without modifications to the tubular reactors (paragraph 16). Determine the DOC and TOC of the stock solution and repeat the measurements for each new batch. If the difference between the DOC and TOC is greater than 20 %, check the water-solubility of the test chemical. Compare the DOC or the concentration of the test chemical measured by specific analysis of the stock solution with the nominal value to ascertain whether recovery is good enough (normally > 90 % can be expected). Ascertain, especially for dispersions, whether or not DOC can be used as an analytical parameter or if only an analytical technique specific for the test chemical can be used. Centrifugation of the samples is required for dispersions. For each new batch, measure the DOC, COD or the test chemical with specific analysis.
27. Determine the pH of the stock solution. Extreme values indicate that the addition of the chemical may have an influence on the pH of the activated sludge in the test system. In this case neutralise the stock solution to obtain a pH of  $7 \pm 0,5$  with small amounts of inorganic acid or base, but avoid precipitation of the test chemical.

## PROCEDURE

*Preparation of organic medium for dosing*

28. Ensure that all influent and effluent containers and tubing from influent vessels and to effluent vessels are thoroughly cleaned to remove microbial growths, initially and throughout the test.
29. Prepare the synthetic sewage (paragraph 23) freshly each day either from the solids or from the concentrated stock solution by appropriate dilution with tap water. Measure the required amount in a cylinder and add to a clean influent vessel. Also, where necessary, add the required amount of the stock solution of the test chemical or reference chemical to the synthetic sewage before dilution. If it is more convenient or necessary to avoid loss of the test chemical, prepare a separate diluted solution of the test chemical in a separate reservoir and deliver this to the inclined tubes via a different dosing pump.
30. Alternatively (and preferably), use settled domestic sewage (paragraph 24) collected freshly each day if possible.

*Operation of rotating tubular reactors*

31. Two identical tubular reactors are required for the assessment of one test chemical, and they are assembled in a constant temperature room normally at  $22 \pm 2$  °C.
32. Adjust the peristaltic pumps to deliver  $250 \pm 25$  ml/h of the organic medium (without test chemical) into the inclined tubes, which are rotated at  $18 \pm 2$  rpm. Apply the lubricant (paragraph 25) to the pump tubes initially and periodically through the test to ensure proper functioning and to prolong the life of the tubing.
33. Adjust the angle of inclination of the tubes to the horizontal to produce a residence time of  $125 \pm 12,5$  sec. for the feed in a clean tube. Estimate the retention time by adding a non-biological marker (e.g. NaCl, inert dye) to the feed: the time taken to reach peak concentration in the effluent is taken to be the mean retention time (when maximum film is present, the retention time can increase up to about 30 min.).
34. These rates, speeds and times have been found to give adequate removals (> 80 %) of DOC (or COD) and to produce nitrified effluents. The rate of flow should be changed if removal is insufficient or if the performance of a particular treatment plant is to be simulated. In the latter case, adjust the rate of dosing the organic medium until the performance of the reactor matches that of the treatment plant.

*Inoculation*

35. Airborne inoculation may be sufficient to start the growth of micro-organisms when synthetic sewage is used, but otherwise add 1 ml/l of settled sewage to the feed for 3 days.

*Measurements*

36. At regular intervals check that the dose-rates and rotating speeds are within the required limits. Also, measure the pH of the effluent, especially if nitrification is expected.

*Sampling and analysis*

37. The method, pattern and frequency of sampling are chosen to suit the purpose of the test. For example, take snap (or grab) samples of influent and effluent, or collect samples over a longer period e.g. 3-6 h. In the first period, without test chemical, take samples twice per week. Filter the samples through membranes or centrifuge at about 40 000 m/sec<sup>2</sup> for about 15 min (paragraph 18). It may be necessary to settle and/or coarse-filter the samples before membrane filtration. Determine DOC (or COD) at least in duplicate and if required BOD, ammonium and nitrite/nitrate.
38. All analyses should be performed as soon as possible after collection and preparation of the samples. If analyses have to be postponed, store the samples at about 4 °C in the dark in full, tightly stoppered bottles. If samples have to be stored for more than 48h, preserve them by deep-freezing, acidification or by addition of a suitable toxic chemical (e.g. 20 ml/l of a 10 g/l solution of mercury (II) chloride). Ensure that the preservation technique does not influence the results of analysis.

*Running-in period*

39. In this period, the surface biofilm grows to reach an optimal thickness, usually taking about 2 weeks and should not exceed 6 weeks. The removal (paragraph 44) of DOC (or COD) increases and reaches a plateau value. When the plateau has been reached at a similar value in both tubes, one is selected to be a control in the remainder of the test, during which their performance should remain consistent.

*Introduction of test chemical*

40. At this stage add the test chemical to the other reactor at the required concentration, usually 10-20 mg C/l. The control continues to receive the organic medium alone.

*Acclimation period*

41. Continue the twice weekly analyses for DOC (or COD) and, if primary biodegradability is to be assessed, also measure the concentration of the test chemical by specific analysis. Allow from one to six weeks (or longer under special conditions) after the test chemical has first been introduced for acclimation to occur. When the percentage removal (paragraphs 43-45) reaches a maximum value, obtain 12-15 valid values in the plateau phase over about 3 weeks for evaluation of the mean percentage removal. The test is considered completed if a sufficiently high degree of elimination is reached. Normally, do not exceed a test duration of more than 12 weeks after the first addition of the test chemical.

*Sloughing of the film*

42. The sudden removal of large quantities of excess film from the tubes, or sloughing, takes place at relatively regular intervals. To ensure that the comparability of results is unaffected, allow tests to cover at least two full cycles of growing and sloughing.

## DATA AND REPORTING

**Treatment of results**

43. Calculate the percentage DOC (or COD) elimination of the test chemical for each timed assessment using the equation:

$$D_t = 100 [C_s - (E - E_0)]/C_s \%$$

where:

$D_t$  = percentage elimination of DOC (or COD) at time  $t$ ;

$C_s$  = concentration of DOC (or COD) in the influent due to the test chemical, preferably estimated from the concentration in, and volume added, of the stock solution (mg/l);

$E$  = measured DOC (or COD) in the test effluent at time  $t$  (mg/l);

$E_o$  = measured DOC (or COD) in the control effluent at time  $t$  (mg/l).

Repeat the calculation for the reference chemical, if tested.

#### Performance of the control reactor

44. The degree of DOC (or COD) elimination ( $D_B$ ) of the organic medium in the control reactors is helpful information in assessing the biodegradative activity of the biofilm during the test. Calculate the percentage elimination from the equation:

$$D_B = 100 (1 - E_o/C_m) \%$$

where:

$C_m$  = DOC (or COD) of the organic medium in the control influent (mg/l).

45. Calculate the removal ( $D_{ST}$ ) of the test chemical, if measured, by a specific analytical method at each time assessment from the equation:

$$D_{ST} = 100 (1 - S_e/S_i) \%$$

where:

$S_i$  = measured or, preferably, estimated concentration of test chemical in the test influent (mg/l)

$S_e$  = measured test chemical concentration in the test effluent at time  $t$  (mg/l)

If the analytical method gives a positive value in unamended sewage equivalent to  $S_c$  mg/l, calculate the percentage removal ( $D_{SC}$ ) from:

$$D_{SC} = 100 (S_i - S_e + S_c)/(S_i + S_c) \%$$

#### Expression of test results

46. Plot the percentage elimination  $D_t$  and  $D_{ST}$  (or  $D_{SC}$ ), if available, versus time (see Appendix 2 in chapter C.10- A). Take the mean (expressed to the nearest whole number) and standard deviation of the 12-15 values for  $D_t$  (and for  $D_{ST}$ , if available) obtained in the plateau phase as the percentage removal of the test chemical. From the shape of the elimination curve, some conclusions may be drawn about the removal processes.

#### Adsorption

47. If a high DOC elimination of the test chemical is observed at the beginning of the test, the test chemical is probably eliminated by adsorption on to the biofilm. It may be possible to prove this by determining the adsorbed test chemical on solids sloughed from the film. It is not usual for the elimination of the DOC of adsorbable chemicals to remain high throughout the test; normally, there is an initial high degree of removal which gradually falls to an equilibrium value. If, however, the adsorbed test chemical was able to cause acclimation of the microbial population, the elimination of the test chemical DOC would subsequently increase and reach a high, plateau level.

#### Lag phase

48. As in static, screening tests many test chemicals require a lag phase before full biodegradation occurs. In the lag phase, acclimation (or adaptation) of the competent bacteria takes place with almost no removal of the test chemical; then the initial growth of these bacteria occurs. This phase ends and the degradation phase is arbitrarily taken to begin when about 10 % of the initial amount of test chemical is removed (after allowing for adsorption, if it occurs). The lag phase is often highly variable and poorly reproducible.

#### Plateau phase

49. The plateau phase of an elimination curve in a continuous test is defined as that phase in which the maximum degradation takes place. This phase should last at least 3 weeks and have about 12-15 measured valid values.

**Mean degree of elimination of the test chemical**

50. Calculate the mean value from the elimination values  $D_t$  (and  $D_{st}$ , if available) of the test chemical at the plateau phase. Rounded to the nearest whole number (1 %), it is the degree of elimination of the test chemical. It is also recommended to calculate the 95 % confidence interval of the mean value. In a similar way calculate the mean degree ( $D_B$ ) of elimination of the organic medium in the control vessel.

**Indication of biodegradation**

51. If the test chemical does not adsorb significantly on to the biofilm and the elimination curve has a typical shape of a biodegradation curve with lag, degradation and plateau phases (paragraphs 48, 49), the measured elimination can safely be attributed to biodegradation. If a high initial removal has taken place, the simulation test cannot differentiate between biological and abiotic elimination processes. In such cases, and in other cases where there is any doubt about biodegradation (e.g. if stripping takes place), analyse adsorbed test chemical on samples of the film or perform additional static (screening) tests for biodegradability based on parameters clearly indicating biological processes. Such tests are the oxygen uptake methods (Chapter C.4 of this Annex D, E and F) (9) or a test which measures  $CO_2$  production (Chapter C.4-C of this Annex or the Headspace method) (10); use as inoculum pre-exposed biofilm from the appropriate reactor.
52. If both the DOC removal and specific chemical removal have been measured, significant differences (the former being lower than the latter) between the percentages removed indicate the presence in the effluents of intermediate organic products, which may be more difficult to degrade; these should be investigated.

**Validity of test results**

53. Consider the test to be valid if the degree of DOC (or COD) elimination ( $D_B$ ) in the control units is  $> 80$  % after 2 weeks operation and no unusual observations have been made.
54. If a readily biodegradable (reference) chemical has been tested, the degree of biodegradation should be  $> 90$  % and the difference between duplicate values should not be greater than 5 %. If these two criteria are not met, review the experimental procedures and/or obtain domestic sewage from another source.
55. Similarly, differences between biodegradation values from duplicate units (if used) treating a test chemical should not differ by more than 5 %. If this criterion is not met but the removals are high, continue analysis for a further three weeks. If removal is low, investigate the inhibitory effects of the test chemical if not known and repeat the test at a lower concentration of test chemical, if that is feasible.

**Test Report**

56. The test report must include the following:

*Test chemical:*

- identification data;
- physical nature and, where relevant, physico-chemical properties.

*Test conditions:*

- any modifications to test system, especially if insolubles or volatiles tested;
- type of organic medium;
- proportion and nature of industrial wastes in sewage, if used and if known;
- method of inoculation;
- test chemical stock solution — DOC (dissolved organic carbon) and TOC (total organic carbon) content; how prepared, if suspension; test concentration(s) used, reasons if outside range 10-20 mg/l DOC; method of addition; date first added; any changes in concentration;

- mean hydraulic retention time (with no growth); rotational speed of tube; approximate angle of inclination, if possible;
- details of sloughing; time and intensity;
- test temperature and range;
- analytical techniques employed.

*Test results:*

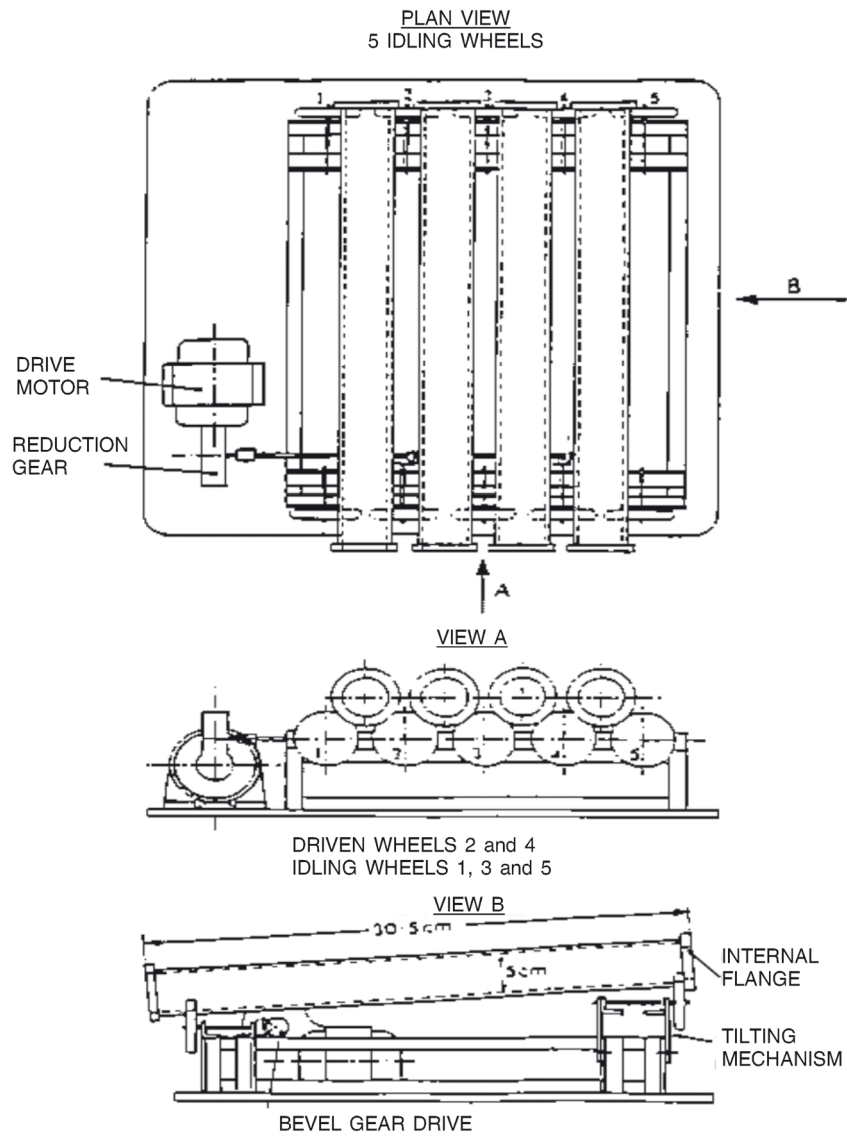
- all measured data DOC, COD, specific analyses, pH, temperature, N chemicals, if relevant;
- all calculated data of  $D_t$  (or  $D_{tc}$ ),  $D_B$ ,  $D_s$  obtained in tabular form and elimination curves;
- information on lag and plateau phases, test duration, the degree of elimination of the test chemical, of the reference chemical (if tested) and of the organic medium (in the control unit), together with statistical data and statements of biodegradability and validity of the test;
- discussion of results.

*LITERATURE:*

- (1) Gerike P, Fischer W, Holtmann W (1980). Biodegradability determinations in trickling filter units compared with the OECD Confirmatory Test. *Wat. Res.* 14: 753-758.
  - (2) Truesdale GA, Jones K, Vandyke KG (1959). Removal of synthetic detergents in sewage treatment processes: Trials of a new biologically attackable material. *Wat. Waste Tr. J.* 7: 441-444.
  - (3) Baumann U, Kuhn G and Benz M. (1998) Einfache Versuchsanordnung zur Gewinnung gewässerökologisch relevanter Daten, UWSF — Z. Umweltchem. Ökotox. 10: 214-220.
  - (4) Gloyne EF, Comstock RF, Renn CE (1952). Rotary tubes as experimental trickling filters. *Sewage ind. Waste* 24: 1355-1357.
  - (5) Kumke GW, Renn CE (1966). LAS removal across an institutional trickling filter. *JAOCS* 43: 92-94.
  - (6) Tomlinson TG, Snaddon DHM, (1966). Biological oxidation of sewage by films of micro-organisms. *Int.J. Air Wat. Pollut.* 10: 865-881.
  - (7) Her Majesty's Stationery Office (1982). Methods for the examination of waters and associated materials. Assessment of biodegradability, 1981, London.
  - (8) Her Majesty's Stationery Office (1984). Methods for the examination of waters and associated materials. Methods for assessing the treatability of chemicals and industrial waste waters and their toxicity to sewage treatment processes, 1982, London.
  - (9) Chapter C.4 of this Annex, Determination of "Ready" Biodegradability A-F.
  - (10) ISO 14593 (1998). Water Quality-Evaluation in an aqueous medium of the ultimate biodegradability of organic substances. Method by analysis of released inorganic carbon in sealed vessels.
-

## Appendix 8

Figure 1

**Rotating tubes***Glossary:*

Plan view:

View A/B:

Driven wheels:

Idling wheels:

Drive motor:

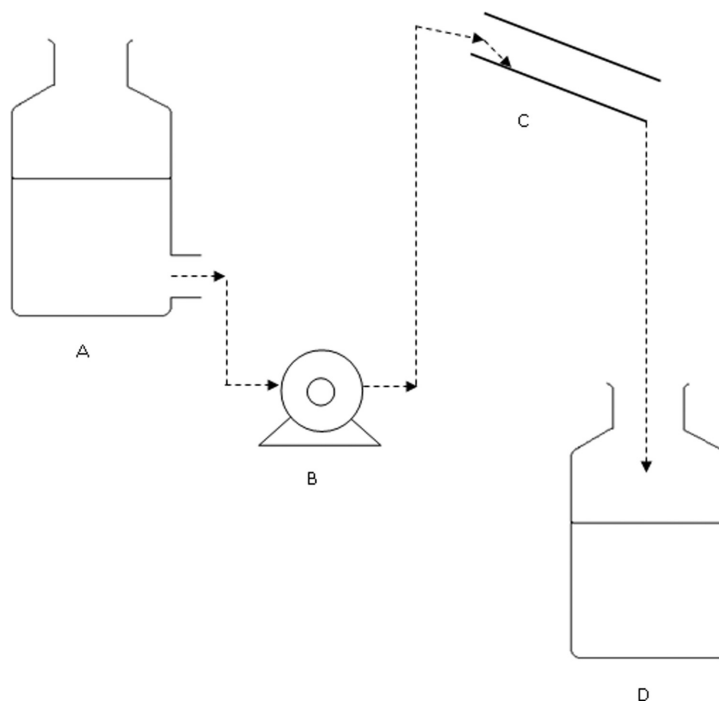
Reduction gear:

Internal flange:

Tilting mechanism:

Bevel gear drive:

Figure 2  
Flow diagram



A: Feed Tank

B: Peristaltic Pump

C: Rotating Tube

D: Effluent Collection Vessel

**DEFINITIONS:**

Test chemical: Any substance or mixture tested using this Test Method.

Chemicals: "It should be noted that the term 'chemical' is used broadly in the UNCED agreements and subsequent documents to include substances, products, mixtures, preparations, or any other terms that may be used in existing systems to denote coverage".

(10) Chapters C.27, C.28, C.29 and C.30 are added:

**'C.27 SEDIMENT-WATER CHIRONOMID TOXICITY TEST USING SPIKED SEDIMENT**

**INTRODUCTION**

1. This Test Method is equivalent to OECD Test Guideline (TG) 218 (2004). This Test Method is designed to assess the effects of prolonged exposure of chemicals to the sediment-dwelling larvae of the freshwater dipteran *Chironomus* sp. It is based on existing toxicity test protocols for *Chironomus riparius* and *Chironomus tentans* which have been developed in Europe (1)(2)(3) and North America (4)(5)(6)(7)(8) and ring-tested (1)(6)(9). Other well documented chironomid species may also be used, e.g. *Chironomus yoshimatsui* (10)(11).
2. The exposure scenario used in this Test Method is spiking of sediment with the test substance. The selection of the appropriate exposure scenario depends on the intended application of the test. The scenario of spiking sediment is intended to simulate accumulated levels of chemicals persisting in the sediment. This exposure system involves spiking sediment of a sediment-water test system.
3. Substances that need to be tested towards sediment-dwelling organisms usually persist in this compartment over long time periods. The sediment-dwelling organisms may be exposed via a number of routes. The relative importance of each exposure route, and the time taken for each to contribute to the overall toxic effects, is dependent on the physical-chemical properties of the chemical concerned. For strongly adsorbing substances

(e.g. with  $\log K_{ow} > 5$ ) or for substances covalently binding to sediment, ingestion of contaminated food may be a significant exposure route. In order not to underestimate the toxicity of highly lipophilic substances, the use of food added to the sediment before application of the test substance may be considered. In order to take all potential routes of exposure into account the focus of this Test Method is on long-term exposure. The test duration is in the range of 20-28 days for *C. riparius* and *C. yoshimatsui*, and 28-65 days for *C. tentans*. If short-term data are required for a specific purpose, for example to investigate the effects of an unstable chemical, additional replicates may be removed after a 10-day period.

4. The measured endpoints are the total number of adults emerged and the time to emergence. It is recommended that measurements of larval survival and growth should only be made after a 10-day period if additional short-term data are required, using additional replicates as appropriate.
5. The use of formulated sediment is recommended. Formulated sediment has several advantages over natural sediments:
  - the experimental variability is reduced because it forms a reproducible “standardised matrix” and the need to find uncontaminated and clean sediment sources is eliminated;
  - the tests can be initiated at any time without encountering seasonal variability in the test sediment and there is no need to pre-treat the sediment to remove indigenous fauna; the use of formulated sediment also reduces the cost associated with the field collection of sufficient amounts of sediment for routine testing;
  - the use of formulated sediment allows for comparisons of toxicity and ranking substances accordingly.
6. Definitions used are given in Appendix 1.

#### PRINCIPLE OF THE TEST

7. First instar chironomid larvae are exposed to a concentration range of the test chemical in sediment — water systems. The test substance is spiked into the sediment and first instar larvae are subsequently introduced into test beakers in which the sediment and water concentrations have been stabilised. Chironomid emergence and development rate is measured at the end of the test. Larval survival and weight may also be measured after 10 days if required (using additional replicates as appropriate). These data are analysed either by using a regression model in order to estimate the concentration that would cause  $\times$  % reduction in emergence or larval survival or growth (e.g.  $EC_{15}$ ,  $EC_{50}$  etc.), or by using statistical hypothesis testing to determine a NOEC/LOEC. The latter requires comparison of effect values with control values using statistical tests.

#### INFORMATION ON THE TEST SUBSTANCE

8. The water solubility of the test substance, its vapour pressure, measured or calculated partitioning into sediment and stability in water and sediment should be known. A reliable analytical method for the quantification of the test substance in overlying water, pore water and sediment with known and reported accuracy and limit of detection should be available. Useful information includes the structural formula and purity of the test substance. Chemical fate of the test substance (e.g. dissipation, abiotic and biotic degradation, etc.) also is useful information. Further guidance for testing substances with physical-chemical properties that make them difficult to perform the test is provided in (12)

#### REFERENCE CHEMICALS

9. Reference chemicals may be tested periodically as a means of assuring that the test protocol and test conditions are reliable. Examples of reference toxicants used successfully in ring-tests and validation studies are: lindane, trifluralin, pentachlorophenol, cadmium chloride and potassium chloride (1)(2)(5)(6)(13).

#### VALIDITY OF THE TEST

10. For the test to be valid the following conditions apply:
  - the emergence in the controls must be at least 70 % at the end of the test. (1)(6);
  - *C. riparius* and *C. yoshimatsui* emergence to adults from control vessels should occur between 12 and 23 days after their insertion into the vessels; for *C. tentans*, a period of 20 to 65 days is necessary.



- at the end of the test, pH and the dissolved oxygen concentration should be measured in each vessel. The oxygen concentration should be at least 60 per cent of the air saturation value (ASV) at the temperature used, and the pH of overlying water should be in the 6-9 range in all test vessels;
- the water temperature should not differ by more than  $\pm 1,0$  °C. The water temperature could be controlled by isothermal room and in that case the room temperature should be confirmed in an appropriate time interval.

#### DESCRIPTION OF THE METHOD

##### Test vessels

11. The study is conducted in glass 600 ml beakers measuring 8 cm in diameter. Other vessels are suitable, but they should guarantee a suitable depth of overlying water and sediment. The sediment surface should be sufficient to provide 2 to 3 cm<sup>2</sup> per larvae. The ratio of the depth of the sediment layer to the depth of the overlying water should be 1:4. Test vessels and other apparatus that will come into contact with the test system should be made entirely of glass or other chemically inert material (e.g. Teflon).

##### Selection of species

12. The species to be used in the test is preferably *Chironomus riparius*. *Chironomus tentans* is also suitable but more difficult to handle and requires a longer test period. *Chironomus yohimatsui* may also be used. Details of culture methods are given in Appendix 2 for *Chironomus riparius*. Information on culture conditions is also available for other species, i.e. *Chironomus tentans* (4) and *Chironomus yohimatsui* (11). Identification of species must be confirmed before testing but is not required prior to every test if organisms come from an in-house culture.

##### Sediment

13. Formulated sediment (also called reconstituted, artificial or synthetic sediment) should preferably be used. However, if natural sediment is used, it should be characterised (at least pH, organic carbon content, determination of other parameters such as C/N ratio and granulometry are also recommended), and it should be free from any contamination and other organisms that might compete with, or consume the chironomids. It is also recommended that, before it is used in a chironomid toxicity test, the natural sediment be conditioned for seven days under the same conditions which prevail in the subsequent test. The following formulated sediment, based on the artificial soil used in Test Method C.8 (14), is recommended for use in this test (1)(15)(16):

- (a) 4-5 % (dry weight) peat: as close to pH 5,5 to 6,0 as possible; it is important to use peat in powder form, finely ground (particle size  $\leq 1$  mm) and only air dried.
- (b) 20 % (dry weight) kaolin clay (kaolinite content preferably above 30 %).
- (c) 75-76 % (dry weight) quartz sand (fine sand should predominate with more than 50 per cent of the particles between 50 and 200  $\mu$ m).
- (d) Deionised water is added to obtain moisture content of the final mixture in a range of 30-50 %.
- (e) Calcium carbonate of chemically pure quality (CaCO<sub>3</sub>) is added to adjust the pH of the final mixture of the sediment to  $7,0 \pm 0,5$ . Organic carbon content of the final mixture should be 2 % ( $\pm 0,5$  %) and is to be adjusted by the use of appropriate amounts of peat and sand, according to (a) and (c).

14. The source of peat, kaolin clay and sand should be known. The sediment components should be checked for the absence of chemical contamination (e.g. heavy metals, organochlorine compounds, organophosphorous compounds, etc.). An example for the preparation of the formulated sediment is described in Appendix 3. Mixing of dry constituents is also acceptable if it is demonstrated that after addition of overlying water a separation of sediment constituents (e.g. floating of peat particles) does not occur, and that the peat or the sediment is sufficiently conditioned.

##### Water

15. Any water which conforms to the chemical characteristics of acceptable dilution water as listed in Appendices 2 and 4 is suitable as test water. Any suitable water, natural water (surface or ground water), reconstituted water (see Appendix 2) or dechlorinated tap water are acceptable as culturing water and test water if chironomids will survive in it for the duration of the culturing and testing without showing signs of stress. At the start of the test,

the pH of the test water should be between 6 and 9 and the total hardness not higher than 400 mg/l as CaCO<sub>3</sub>. However, if there is an interaction suspected between hardness ions and the test substance, lower hardness water should be used (and thus, Elendt Medium M4 must not be used in this situation). The same type of water should be used throughout the whole study. The water quality characteristics listed in Appendix 4 should be measured at least twice a year or when it is suspected that these characteristics may have changed significantly.

#### **Stock solutions — Spiked sediments**

16. Spiked sediments of the chosen concentration are usually prepared by addition of a solution of the test substance directly to the sediment. A stock solution of the test substance dissolved in deionised water is mixed with the formulated sediment by rolling mill, feed mixer or hand mixing. If poorly soluble in water, the test substance can be dissolved in as small a volume as possible of a suitable organic solvent (e.g. hexane, acetone or chloroform). This solution is then mixed with 10 g of fine quartz sand for one test vessel. The solvent is allowed to evaporate and it has to be totally removed from sand; the sand is then mixed with the suitable amount of sediment per test beaker. Only agents which volatilise readily can be used to solubilise, disperse or emulsify the test substance. It should be born in mind that the sand provided by the test substance and sand mixture, has to be taken into account when preparing the sediment (i.e. the sediment should thus be prepared with less sand). Care should be taken to ensure that the test substance added to sediment is thoroughly and evenly distributed within the sediment. If necessary, subsamples can be analysed to determine degree of homogeneity.

#### **TEST DESIGN**

17. The test design relates to the selection of the number and spacing of the test concentrations, the number of vessels at each concentration and the number of larvae per vessel. Designs for EC point estimation, for estimation of NOEC, and for conducting a limit test are described.

#### **Design for analysis by regression**

18. The effect concentration (e.g. EC<sub>15</sub>, EC<sub>50</sub>) and the concentration range, over which the effect of the test substance is of interest, should be spanned by the concentrations included in the test. Generally, the accuracy and especially validity, with which estimates of effect concentrations (EC<sub>x</sub>) can be made, is improved when the effect concentration is within the range of concentrations tested. Extrapolating much below the lowest positive concentration or above the highest concentration should be avoided. A preliminary range-finding test is helpful for selecting the range of concentrations to be used (see paragraph 27).
19. If the EC<sub>x</sub> is to be estimated, at least five concentrations and three replicates for each concentration should be tested. In any case, it is advisable that sufficient test concentrations are used to allow good model estimation. The factor between concentrations should not be greater than two (an exception could be made in cases when the dose response curve has a shallow slope). The number of replicates at each treatment can be reduced if the number of test concentrations with different responses is increased. Increasing the number of replicates or reducing the size of the test concentration intervals tends to lead to narrower confidence intervals for the test. Additional replicates are required if 10-day larval survival and growth are to be estimated.

#### **Design for estimation of a NOEC/LOEC**

20. If the LOEC or NOEC are to be estimated, five test concentrations with at least four replicates should be used and the factor between concentrations should not be greater than two. The number of replicates should be sufficient to ensure adequate statistical power to detect a 20 % difference from the control at the 5 % level of significance (p = 0,05). With the development rate, an Analysis of Variance (ANOVA) is usually appropriate, such as Dunnett-test and Williams-test (17)(18)(19)(20). In the emergence ratio the Cochran-Armitage, Fisher's exact (with Bonferroni correction), or Mantel-Haenszel tests may be used.

#### **Limit test**

21. A limit test may be performed (one test concentration and control) if no effects were seen in the preliminary range-finding test. The purpose of the limit test is to perform a test at a concentration sufficiently high to enable decision makers to exclude possible toxic effects of the test substance, and the limit is set at a concentration which is not expected to appear in any situation. 1 000 mg/kg (dry weight) is recommended. Usually, at least six replicates for both the treatment and control are necessary. Adequate statistical power to detect a 20 % difference from the control at the 5 % level of significance (p = 0,05) should be demonstrated. With metric response (development rate and weight), the t-test is a suitable statistical method if data meet the requirements of this test (normality, homogeneous variances). The unequal-variance t-test or a non parametric test, such as the Wilcoxon-Mann-Whitney test may be used, if these requirements are not fulfilled. With the emergence ratio, the Fisher exact test is appropriate.

## PROCEDURE

**Conditions of exposure***Preparation of spiked sediment — water system*

22. The spiking procedure described in Test Method C.8: Toxicity for Earthworms is recommended for application of the test substance (14). The spiked sediments are placed in the vessels and overlying water is added to produce a sediment-water volume ratio of 1:4 (see paragraphs 11 and 15). The depth of the sediment layer should be in the range of 1,5-3 cm. To avoid separation of sediment ingredients and re-suspension of fine material during addition of test water in the water column, the sediment can be covered with a plastic disc while water is poured onto it, and the disc removed immediately afterwards. Other devices may also be appropriate.
23. The test vessels should be covered (e.g. by glass plates). If necessary, during the study the water levels will be topped to the original volume in order to compensate for water evaporation. This should be performed using distilled or deionised water to prevent build-up of salts.

*Stabilisation*

24. Once the spiked sediment with overlying water has been prepared, it is desirable to allow partitioning of the test substance from the aqueous phase to the sediment (3)(4)(6)(13). This should preferably be done under the conditions of temperature and aeration used in the test. Appropriate equilibration time is sediment and chemical specific, and can be in the order of hours to days and in rare cases up to several weeks (4-5 weeks). As this would leave time for degradation of many chemicals, equilibrium is not awaited but an equilibration period of 48 hours is recommended. At the end of this further equilibration period, the concentration of the test substance should be measured in the overlying water, the pore water and the sediment, at least at the highest concentration and a lower one (see paragraph 38). These analytical determinations of the test substance allow for calculation of mass balance and expression of results based on measured concentrations.

*Addition of test organisms*

25. Four to five days before adding the test organisms to the test vessels, egg masses should be taken from the cultures and placed in small vessels in culture medium. Aged medium from the stock culture or freshly prepared medium may be used. If the latter is used, a small amount of food e.g. green algae and/or a few droplets of filtrate from a finely ground suspension of flaked fish food should be added to the culture medium (see Appendix 2). Only freshly laid egg masses should be used. Normally, the larvae begin to hatch a couple of days after the eggs are laid (2 to 3 days for *Chironomus riparius* at 20 °C and 1 to 4 days for *Chironomus tentans* at 23 °C and *Chironomus yoshimatui* at 25 °C) and larval growth occurs in four instars, each of 4-8 days duration. First instar larvae (2-3 or 1-4 days post hatching) should be used in the test. The instar of midges can possibly be checked using head capsule width (6).
26. Twenty first instar larvae are allocated randomly to each test vessel containing the spiked sediment and water, using a blunt pipette. Aeration of the water has to be stopped while adding the larvae to test vessels and remain so for another 24 hours after addition of larvae (see paragraphs 25 and 32). According to the test design used (see paragraphs 19 and 20), the number of larvae used per concentration is at least 60 for the EC point estimation and 80 for determination of NOEC.

*Test concentrations*

27. A range-finding test may be helpful to determine the range of concentrations for the definitive test. For this purpose a series of widely spaced concentrations of the test substance are used. In order to provide the same density of surface per chironomids, which is to be used for the definitive test, chironomids are exposed to each concentration of the test substance for a period which allows estimation of appropriate test concentrations, and no replicates are required.
28. The test concentrations for the definitive test are decided based on the result of the range-finding test. At least five concentrations should be used and selected as described in paragraphs 18 to 20.

*Controls*

29. Control vessels without any test substance but including sediment should be included in the test with the appropriate number of replicates (see paragraphs 19-20). If a solvent has been used for application of test substance (see paragraph 16), a sediment solvent control should be added.

#### Test system

30. Static systems are used. Semi-static or flow-through systems with intermittent or continuous renewal of overlying water might be used in exceptional cases as for instance if water quality specifications become inappropriate for the test organism or affect chemical equilibrium (e.g. dissolved oxygen levels fall too low, the concentration of excretory products rises too high or minerals leach from sediment and affect pH and/or water hardness). However, other methods for ameliorating the quality of overlying water, such as aeration, will normally suffice and be preferable.

#### Food

31. It is necessary to feed the larvae, preferably daily or at least three times per week. Fish-food (a suspension in water or finely ground food, e.g. TetraMin or TetraPhyll; see details in Appendix 2) in the amount of 0,25-0,5 mg (0,35-0,5 mg for *C. yoshimatsu*) per larvae per day seems adequate for young larvae for the first 10 days. Slightly more food may be necessary for older larvae: 0,5-1 mg per larvae per day should be sufficient for the rest of the test. The food ration should be reduced in all treatments and control if fungal growth is seen or if mortality is observed in controls. If fungal development cannot be stopped the test is to be repeated. When testing strongly adsorbing substances (e.g. with  $\log K_{ow} > 5$ ), or substances covalently binding to sediment, the amount of food necessary to ensure survival and natural growth of the organisms may be added to the formulated sediment before the stabilisation period. For this, plant material must be used instead of fish food, e.g. addition of 0,5 % (dry weight) finely ground leaves of e.g. stinging nettle (*Urtica dioica*), mulberry (*Morus alba*), white clover (*Trifolium repens*), spinach (*Spinacia oleracea*) or of other plant material (*Cerophyl* or alpha-cellulose) may be used.

#### Incubation conditions

32. Gentle aeration of the overlying water in test vessels is supplied preferably 24 hours after addition of the larvae and is pursued throughout the test (care should be taken that dissolved oxygen concentration does not fall below 60 per cent of ASV). Aeration is provided through a glass Pasteur pipette fixed 2-3 cm above the sediment layer (i.e. one or few bubbles/sec). When testing volatile chemicals, consideration may be given not to aerate the sediment-water system.
33. The test is conducted at a constant temperature of 20 °C ( $\pm 2$  °C). For *C. tentans* and *C. yoshimatsu* recommended temperatures are 23 °C and 25 °C ( $\pm 2$  °C), respectively. A 16 hours photoperiod is used and the light intensity should be 500 to 1 000 lux.

#### Exposure duration

34. The exposure commences with the addition of larvae to the spiked and control vessels. The maximum exposure duration is 28 days for *C. riparius* and *C. yoshimatsu*, and 65 days for *C. tentans*. If midges emerge earlier, the test can be terminated after a minimum of five days after emergence of the last adult in the control.

### Observations

#### Emergence

35. The development time and the total number of fully emerged male and female midges are determined. Males are easily identified by their plumose antennae.
36. The test vessels should be observed at least three times per week to make visual assessment of any abnormal behaviour (e.g. leaving sediment, unusual swimming), compared with the control. During the period of expected emergence a daily count of emerged midges is necessary. The sex and number of fully emerged midges are recorded daily. After identification the midges are removed from the vessels. Any egg masses deposited prior to the termination of the test should be recorded and then removed to prevent re-introduction of larvae into the sediment. The number of visible pupae that have failed to emerge is also recorded. Guidance on measurement of emergence is provided in Appendix 5.

#### Growth and survival

37. If data on 10-day larval survival and growth are to be provided, additional test vessels should be included at the start, so that they may be used subsequently. The sediment from these additional vessels is sieved using a 250  $\mu$ m sieve to retain the larvae. Criteria for death are immobility or lack of reaction to a mechanical stimulus. Larvae not recovered should also be counted as dead (larvae which have died at beginning of the test may have been degraded by microbes). The (ash free) dry weight of the surviving larvae per test vessel is determined and the mean individual dry weight per vessel calculated. It is useful to determine which instar the surviving larvae belong to; for that measurement of the width of the head capsule of each individual can be used.

### Analytical measurements

#### *Concentration of the test substance*

38. Prior to test commencement (i.e. addition of larvae), samples of bulk sediment are removed from at least one vessel per treatment for the analytical determination of the test substance concentration in the sediment. It is recommended that, as a minimum, samples of the overlying water, the pore water and the sediment be analysed at the start (see paragraph 24) and at the end of the test, at the highest concentration and a lower one. These determinations of test substance concentration inform about the behaviour/partitioning of the test substance in the water-sediment system.
39. When intermediate measurements are made (e.g. at day 7) and if the analysis needs large samples which cannot be taken from test vessels without influencing the test system, analytical determinations should be performed on samples from additional test vessels treated in the same way (including the presence of test organisms) but not used for biological observations.
40. Centrifugation at e.g. 10 000 g and 4 °C for 30 min. is the recommended procedure to isolate interstitial water. However, if the test substance is demonstrated not to adsorb to filters, filtration may also be acceptable. In some cases it might not be possible to analyse concentrations in the pore water as the sample size is too small.

#### *Physical-chemical parameters*

41. pH and temperature of the test vessels should be measured in an appropriate manner (see paragraph 10). Hardness and ammonia should be measured in the controls and one test vessel at the highest concentration at the start and the end of the test.

### DATA AND REPORTING

#### *Treatment of results*

42. The purpose of this test is to determine the effect of the test substance on the development rate and the total number of fully emerged male and female midges, or in the case of the 10-day test effects on survival and weight of the larvae. If there are no indications of statistically different sensitivities of sexes, male and female results may be pooled for statistical analyses. The sensitivity differences between sexes can be statistically judged by e.g. a  $\chi^2$ -r  $\times$  2 table test. Larval survival and mean individual dry weight per vessel must be determined after 10 days where required.
43. Effect concentrations expressed and based on dry weight, are calculated preferably based on measured sediment concentrations at the beginning of the test (see paragraph 38).
44. To compute a point estimate for the EC<sub>50</sub> or any other EC<sub>x</sub>, the per-vessel statistics may be used as true replicates. In calculating a confidence interval for any EC<sub>x</sub> the variability among vessels should be taken into account, or it should be shown that this variability is so small that it can be ignored. When the model is fitted by Least Squares, a transformation should be applied to the per-vessel statistics in order to improve the homogeneity of variance. However, EC<sub>x</sub> values should be calculated after the response is transformed back to the original value.
45. When the statistical analysis aims at determining the NOEC/LOEC by hypothesis testing, the variability among vessels needs to be taken into account, e.g. by a nested ANOVA. Alternatively, more robust tests (21) can be appropriate in situations where there are violations of the usual ANOVA assumptions.

#### *Emergence ratio*

46. Emergence ratios are quantal data, and can be analyzed by the Cochran-Armitage test applied in step-down manner where a monotonic dose-response is expected and these data are consistent with this expectation. If not, a Fisher's exact or Mantel-Haenszel test with Bonferroni-Holm adjusted p-values can be used. If there is evidence of greater variability between replicates within the same concentration than a binomial distribution would indicate (often referenced as "extra-binomial" variation), then a robust Cochran-Armitage or Fisher exact test such as proposed in (21), should be used.

The sum of midges emerged per vessel,  $n_e$ , is determined and divided by the number of larvae introduced,  $n_a$ :

$$ER = \frac{n_e}{n_a}$$

where:

$ER$  = emergence ratio

$n_e$  = number of midges emerged per vessel

$n_a$  = number of larvae introduced per vessel

47. An alternative that is most appropriate for large sample sizes, when there is extra binomial variance, is to treat the emergence ratio as a continuous response and use procedures such as William's test when a monotonic dose-response is expected and is consistent with these ER data. Dunnett's test would be appropriate where monotonicity does not hold. A large sample size is defined here as the number emerged and the number not emerging both exceeding five, on a per replicate (vessel) basis.
48. To apply ANOVA methods values of ER should first be transformed by the arcsin-sqrt-transformation or Freeman-Tukey transformation to obtain an approximate normal distribution and to equalise variances. The Cochran-Armitage, Fisher's exact (Bonferroni), or Mantel-Haenszel tests can be applied when using the absolute frequencies. The arcsin-sqrt transformation is applied by taking the inverse sine ( $\sin^{-1}$ ) of the square root of ER.
49. For emergence ratios,  $EC_x$ -values are calculated using regression analysis (or e.g. probit (22), logit, Weibull, appropriate commercial software etc.). If regression analysis fails (e.g. when there are less than two partial responses), other non-parametric methods such as moving average or simple interpolation are used.

#### *Development rate*

50. The mean development time represents the mean time span between the introduction of larvae (day 0 of the test) and the emergence of the experimental cohort of midges. (For the calculation of the true development time, the age of larvae at the time of introduction should be considered). The development rate is the reciprocal of the development time (unit: 1/day) and represents that portion of larval development which takes place per day. The development rate is preferred for the evaluation of these sediment toxicity studies as its variance is lower, and it is more homogeneous and closer to normal distribution as compared to development time. Hence, powerful parametric test procedures may be used with development rate rather than with development time. For development rate as a continuous response,  $EC_x$ -values can be estimated by using regression analysis (e.g. (23), (24)).
51. For the following statistical tests, the number of midges observed on inspection day  $x$  are assumed to be emerged at the mean of the time interval between day  $x$  and day  $x - 1$  ( $l$  = length of the inspection interval, usually 1 day). The mean development rate per vessel ( $\bar{x}$ ) is calculated according to:

$$\bar{x} = \frac{\sum_{i=1}^m f_i x_i}{n_e}$$

where:

$\bar{x}$ : mean development rate per vessel

$i$ : index of inspection interval

$m$ : maximum number of inspection intervals

$f_i$ : number of midges emerged in the inspection interval  $i$

$n_e$ : total number of midges emerged at the end of experiment (=  $\sum f_i$ )

$x_i$ : development rate of the midges emerged in interval  $i$

$$x_i = \frac{1}{\left(\text{day}_i - \frac{l_i}{2}\right)}$$

where:

$\text{day}_i$ : inspection day (days since application)

$l_i$ : length of inspection interval  $i$  (days, usually 1 day)

**Test report**

52. The test report must at least provide the following information:

*Test substance:*

- physical nature and, where relevant, physical-chemical properties (water solubility, vapour pressure, partition coefficient in soil (or in sediment if available), stability in water, etc.);
- chemical identification data (common name, chemical name, structural formula, CAS number, etc.) including purity and analytical method for quantification of test substance.

*Test species:*

- test animals used: species, scientific name, source of organisms and breeding conditions;
- information on handling of egg masses and larvae;
- age of test animals when inserted into test vessels.

*Test conditions:*

- sediment used, i.e. natural or formulated sediment;
- for natural sediment, location and description of sediment sampling site, including, if possible, contamination history; characteristics: pH, organic carbon content, C/N ratio and granulometry (if appropriate).
- preparation of the formulated sediment: ingredients and characteristics (organic carbon content, pH, moisture, etc. at the start of the test);
- preparation of the test water (if reconstituted water is used) and characteristics (oxygen concentration, pH, conductivity, hardness, etc. at the start of the test);
- depth of sediment and overlying water;
- volume of overlying and pore water; weight of wet sediment with and without pore water;
- test vessels (material and size);
- method of spiking sediment: test concentrations used, number of replicates and use of solvent if any;
- stabilisation equilibrium phase of the spiked sediment-water system: duration and conditions;
- incubation conditions: temperature, light cycle and intensity, aeration (frequency and intensity);
- detailed information on feeding including type of food, preparation, amount and feeding regime.

*Results:*

- the nominal test concentrations, the measured test concentrations and the results of all analyses to determine the concentration of the test substance in the test vessel;
- water quality within the test vessels, i.e. pH, temperature, dissolved oxygen, hardness and ammonia;
- replacement of evaporated test water, if any;
- number of emerged male and female midges per vessel and per day;
- number of larvae which failed to emerge as midges per vessel;
- mean individual dry weight of larvae per vessel, and per instar, if appropriate;
- percent emergence per replicate and test concentration (male and female midges pooled);



- mean development rate of fully emerged midges per replicate and treatment rate (male and female midges pooled);
- estimates of toxic endpoints e.g. ECx (and associated confidence intervals), NOEC and/or LOEC, and the statistical methods used for their determination;
- discussion of the results, including any influence on the outcome of the test resulting from deviations from this Test Method.

**LITERATURE:**

- (1) BBA (1995). Long-term toxicity test with *Chironomus riparius*: Development and validation of a new test system. Edited by M. Streloke and H.Köpp. Berlin 1995.
- (2) Fleming R *et al.* (1994). Sediment Toxicity Tests for Poorly Water-Soluble Substances. Final Report to them European Commission. Report No: EC 3738. August 1994. WRC, UK.
- (3) SETAC (1993). Guidance Document on Sediment toxicity Tests and Bioassays for Freshwater and Marine Environments. From the WOSTA Workshop held in the Netherlands.
- (4) ASTM International/E1706-00 (2002). Test Method for Measuring the Toxicity of Sediment-Associated Contaminants with Freshwater Invertebrates. pp 1125-1241. In ASTM International 2002 Annual Book of Standards. Volume 11.05. Biological Effects and Environmental Fate;Biotechnology; Pesticides. ASTM. International, West Conshohocken, PA.
- (5) Environment Canada (1997). Test for Growth and Survival in Sediment using Larvae of Freshwater Midges (*Chironomus tentans* or *Chironomus riparius*). Biological Test Method. Report SPE 1/RM/32. December 1997.
- (6) US-EPA (2000). Methods for Measuring the Toxicity and Bioaccumulation of Sediment-associated Contaminants with Freshwater Invertebrates. Second edition. EPA 600/R-99/064. March 2000. Revision to the first edition dated June 1994.
- (7) US-EPA/OPPTS 850.1735. (1996): Whole Sediment Acute Toxicity Invertebrates.
- (8) US-EPA/OPPTS 850.1790. (1996): Chironomid Sediment toxicity Test.
- (9) Milani D, Day KE, McLeay DJ, and Kirby RS (1996). Recent intra- and inter-laboratory studies related to the development and standardisation of Environment Canada's biological test methods for measuring sediment toxicity using freshwater amphipods (*Hyalella azteca*) and midge larvae (*Chironomus riparius*). Technical Report. Environment Canada. National Water Research Institute. Burlington, Ontario, Canada.
- (10) Sugaya Y (1997). Intra-specific variations of the susceptibility of insecticides in *Chironomus yoshimatsui*. Jp. J. Sanit. Zool. 48 (4): 345-350.
- (11) Kawai K (1986). Fundamental studies on Chironomid allergy. I. Culture methods of some Japanese Chironomids (Chironomidae, Diptera). Jp. J. Sanit. Zool. 37(1): 47-57.
- (12) OECD (2000). Guidance Document on Aquatic Toxicity Testing of Difficult Substances and Mixtures. OECD Environment, Health and Safety Publications, Series on Testing and Assessment No 23.
- (13) Environment Canada (1995). Guidance Document on Measurement of Toxicity Test Precision Using Control Sediments Spiked with a Reference Toxicant. Report EPS 1/RM/30. September 1995.
- (14) Test Method C.8 of this Annex, Toxicity for Earthworms.
- (15) Suedel BC and JH Rodgers (1994). Development of formulated reference sediments for freshwater and estuarine sediment testing. Environ. Toxicol. Chem. 13: 1163-1175.
- (16) Naylor C and C Rodrigues (1995). Development of a test method for *Chironomus riparius* using a formulated sediment. Chemosphere 31: 3291-3303.



- 
- (17) Dunnett CW (1964). A multiple comparisons procedure for comparing several treatments with a control. *J. Amer. Statis. Assoc.*, 50: 1096-1121.
  - (18) Dunnett CW (1964). New tables for multiple comparisons with a control. *Biometrics*, 20: 482-491.
  - (19) Williams DA (1971). A test for differences between treatment means when several dose levels are compared with a zero dose control. *Biometrics*, 27: 103-117.
  - (20) Williams DA (1972). The comparison of several dose levels with a zero dose control. *Biometrics*, 28: 510-531.
  - (21) Rao JNK and Scott AJ (1992). A simple method for the analysis of clustered binary data. *Biometrics* 48: 577-585.
  - (22) Christensen ER (1984). Dose-response functions in aquatic toxicity testing and the Weibull model. *Water Research* 18: 213-221.
  - (23) Bruce and Versteeg (1992). A statistical procedure for modelling continuous toxicity data. *Environmental Toxicology and Chemistry* 11: 1485-1494.
  - (24) Slob W (2002). Dose-response modelling of continuous endpoints. *Toxicol. Sci.* 66: 298-312.
-

*Appendix 1*

## DEFINITIONS

For the purpose of this Test Method the following definitions are used:

**Formulated sediment** or reconstituted, artificial or synthetic sediment, is a mixture of materials used to mimic the physical components of a natural sediment.

**Overlying water** is the water placed over sediment in the test vessel.

**Interstitial water** or pore water is the water occupying space between sediment and soil particles.

**Spiked sediment** is sediment to which test substance has been added.

**Test chemical:** Any substance or mixture tested using this Test Method.

---

## Appendix 2

**Recommendations for culture of *Chironomus riparius***

1. *Chironomus* larvae may be reared in crystallising dishes or larger containers. Fine quartz sand is spread in a thin layer of about 5 to 10 mm deep over the bottom of the container. Kieselguhr (e.g. Merck, Art 8117) has also been shown to be a suitable substrate (a thinner layer of up to a very few mm is sufficient). Suitable water is then added to a depth of several cm. Water levels should be topped up as necessary to replace evaporative loss, and prevent desiccation. Water can be replaced if necessary. Gentle aeration should be provided. The larval rearing vessels should be held in a suitable cage which will prevent escape of the emerging adults. The cage should be sufficiently large to allow swarming of emerged adults, otherwise copulation may not occur (minimum is ca. 30 × 30 × 30 cm).
2. Cages should be held at room temperature or in a constant environment room at 20 ± 2 °C with a photo period of 16 hour light (intensity ca. 1 000 lux), 8 hours dark. It has been reported that air humidity of less than 60 % RH can impede reproduction.

**Dilution water**

3. Any suitable natural or synthetic water may be used. Well water, dechlorinated tap water and artificial media (e.g. ElenDt "M4" or "M7" medium, see below) are commonly used. The water has to be aerated before use. If necessary, the culture water may be renewed by pouring or siphoning the used water from culture vessels carefully without destroying the tubes of larvae.

**Feeding larvae**

4. *Chironomus* larvae should be fed with a fish flake food (TetraMin® TetraPhyll® or other similar brand of proprietary fish food), at approximately 250 mg per vessel per day. This can be given as a dry ground powder or as a suspension in water: 1,0 g of flake food is added to 20 ml of dilution water and blended to give a homogenous mix. This preparation may be fed at a rate of about 5 ml per vessel per day (shake before use). Older larvae may receive more.
5. Feeding is adjusted according to the water quality. If the culture medium becomes "cloudy", the feeding should be reduced. Food additions must be carefully monitored. Too little food will cause emigration of the larvae towards the water column, and too much food will cause increased microbial activity and reduced oxygen concentrations. Both conditions can result in reduced growth rates.
6. Some green algae (e.g. *Scenedesmus subspicatus*, *Chlorella vulgaris*) cells may also be added when new culture vessels are set up.

**Feeding emerged adults**

7. Some experimenters have suggested that a cotton wool pad soaked in a saturated sucrose solution may serve as a food for emerged adults.

**Emergence**

8. At 20 ± 2 °C adults will begin to emerge from the larval rearing vessels after approximately 13-15 days. Males are easily distinguished by having plumose antennae.

**Egg masses**

9. Once adults are present within the breeding cage, all larval rearing vessels should be checked three times weekly for deposition of the gelatinous egg masses. If present, the egg masses should be carefully removed. They should be transferred to a small dish containing a sample of the breeding water. Egg masses are used to start a new culture vessel (e.g. 2-4 egg masses/vessel) or are used for toxicity tests.
10. First instar larvae should hatch after 2-3 days.

**Set-up of new culture vessels**

11. Once cultures are established it should be possible to set up a fresh larval culture vessel weekly or less frequently depending on testing requirements, removing the older vessels after adult midges have emerged. Using this system a regular supply of adults will be produced with a minimum of management.

### Preparation of test solutions “M4” and “M7”

12. Elendt (1990) has described the “M4” medium. The “M7” medium is prepared as the “M4” medium except for the substances indicated in Table 1, for which concentrations are four times lower in “M7” than in “M4”. A publication on the “M7” medium is in preparation (Elendt, personal communication). The test solution should not be prepared according to Elendt and Bias (1990) for the concentrations of  $\text{NaSiO}_3 \cdot 5 \text{H}_2\text{O}$ ,  $\text{NaNO}_3$ ,  $\text{KH}_2\text{PO}_4$  and  $\text{K}_2\text{HPO}_4$  given for the preparation of the stock solutions are not adequate.

### Preparation of the “M7”-medium

13. Each stock solution (I) is prepared individually and a combined stock solution (II) is prepared from these stock solutions (I) (see Table 1). Fifty ml from the combined stock Solution (II) and the amounts of each macro nutrient stock solution which are given in Table 2 are made up to 1 litre of deionised water to prepare the “M7” medium. A vitamin stock solution is prepared by adding three vitamins to deionised water as indicated in Table 3, and 0,1 ml of the combined vitamin stock solution are added to the final “M7” medium shortly before use. (The vitamin stock solution is stored frozen in small aliquots). The medium is aerated and stabilised.

### LITERATURE:

BBA (1995). Long-term toxicity test with *Chironomus riparius*: Development and validation of a new test system. Edited by M. Strelöke and H. Köpp. Berlin 1995.

Table 1

Stock solutions of trace elements for medium M4 and M7

Stock solutions (I)	Amount (mg) made up to 1 litre of deionised water	To prepare the combined stock solution (II): mix the following amounts (ml) of stock solutions (I) and make up to 1 litre of deionised water		Final concentrations in test solutions (mg/l)	
		M4	M7	M4	M7
$\text{H}_3\text{BO}_3$ <sup>(1)</sup>	57 190	1,0	0,25	2,86	0,715
$\text{MnCl}_2 \cdot 4 \text{H}_2\text{O}$ <sup>(1)</sup>	7 210	1,0	0,25	0,361	0,090
$\text{LiCl}$ <sup>(1)</sup>	6 120	1,0	0,25	0,306	0,077
$\text{RbCl}$ <sup>(1)</sup>	1 420	1,0	0,25	0,071	0,018
$\text{SrCl}_2 \cdot 6 \text{H}_2\text{O}$ <sup>(1)</sup>	3 040	1,0	0,25	0,152	0,038
$\text{NaBr}$ <sup>(1)</sup>	320	1,0	0,25	0,016	0,004
$\text{Na}_2\text{MoO}_4 \cdot 2 \text{H}_2\text{O}$ <sup>(1)</sup>	1 260	1,0	0,25	0,063	0,016
$\text{CuCl}_2 \cdot 2 \text{H}_2\text{O}$ <sup>(1)</sup>	335	1,0	0,25	0,017	0,004
$\text{ZnCl}_2$	260	1,0	1,0	0,013	0,013
$\text{CaCl}_2 \cdot 6 \text{H}_2\text{O}$	200	1,0	1,0	0,010	0,010
$\text{KI}$	65	1,0	1,0	0,0033	0,0033
$\text{Na}_2\text{SeO}_3$	43,8	1,0	1,0	0,0022	0,0022
$\text{NH}_4\text{VO}_3$	11,5	1,0	1,0	0,00058	0,00058
$\text{Na}_2\text{EDTA} \cdot 2 \text{H}_2\text{O}$ <sup>(1) (2)</sup>	5 000	20,0	5,0	2,5	0,625
$\text{FeSO}_4 \cdot 7 \text{H}_2\text{O}$ <sup>(1) (2)</sup>	1 991	20,0	5,0	1,0	0,249

<sup>(1)</sup> These substances differ in M4 and M7, as indicated above.

<sup>(2)</sup> These solutions are prepared individually, then poured together and autoclaved immediately.

Table 2

**Macro nutrient stock solutions for medium M4 and M7**

	Amount made up to 1 litre of deionised water (mg)	Amount of macro nutrient stock solutions added to prepare medium M4 and M7 (ml/l)	Final concentrations in test solutions M4 and M7 (mg/l)
CaCl <sub>2</sub> · 2 H <sub>2</sub> O	293 800	1,0	293,8
MgSO <sub>4</sub> · 7 H <sub>2</sub> O	246 600	0,5	123,3
KCl	58 000	0,1	5,8
NaHCO <sub>3</sub>	64 800	1,0	64,8
NaSiO <sub>3</sub> · 9 H <sub>2</sub> O	50 000	0,2	10,0
NaNO <sub>3</sub>	2 740	0,1	0,274
KH <sub>2</sub> PO <sub>4</sub>	1 430	0,1	0,143
K <sub>2</sub> HPO <sub>4</sub>	1 840	0,1	0,184

Table 3

**Vitamin stock solution for medium M4 and M7. All three vitamin solutions are combined to make a single vitamin stock solution**

	Amount made up to 1 litre of deionised water (mg)	Amount of vitamin stock solution added to prepare medium M4 and M7 (ml/l)	Final concentrations in test solutions M4 and M7 (mg/l)
Thiamine hydrochloride	750	0,1	0,075
Cyanocobalamin (B12)	10	0,1	0,0010
Biotine	7,5	0,1	0,00075

**LITERATURE:**

ElenDt, B.P. (1990). Selenium Deficiency in Crustacean. *Protoptasma* 154: 25-33.

ElenDt, B.P. & W.-R. Bias (1990). Trace Nutrient Deficiency in *Daphnia magna* Cultured in Standard Medium for Toxicity Testing. Effects on the Optimization of Culture Conditions on Life History Parameters of *D. magna*. *Water Research* 24 (9): 1157-1167.

## Appendix 3

## PREPARATION OF FORMULATED SEDIMENT

**Sediment composition**

The composition of the formulated sediment should be as follows:

Constituent	Characteristics	% of sediment dry weight
Peat	Sphagnum moss peat, as close to pH 5,5-6,0 as possible, no visible plant remains, finely ground (particle size $\leq$ 1 mm) and air dried	4-5
Quartz sand	Grain size: > 50 % of the particles should be in the range of 50-200 $\mu$ m	75-76
Kaolinite clay	Kaolinite content $\geq$ 30 %	20
Organic carbon	Adjusted by addition of peat and sand	2 ( $\pm$ 0,5)
Calcium carbonate	CaCO <sub>3</sub> , pulverised, chemically pure	0,05-0,1
Water	Conductivity $\leq$ 10 $\mu$ S/cm	30-50

**Preparation**

The peat is air dried and ground to a fine powder. A suspension of the required amount of peat powder in deionised water is prepared using a high-performance homogenising device. The pH of this suspension is adjusted to  $5,5 \pm 0,5$  with CaCO<sub>3</sub>. The suspension is conditioned for at least two days with gentle stirring at  $20 \pm 2$  °C, to stabilise pH and establish a stable microbial component. pH is measured again and should be  $6,0 \pm 0,5$ . Then the peat suspension is mixed with the other constituents (sand and kaolin clay) and deionised water to obtain a homogeneous sediment with a water content in a range of 30-50 per cent of dry weight of the sediment. The pH of the final mixture is measured once again and is adjusted to 6,5 to 7,5 with CaCO<sub>3</sub> if necessary. Samples of the sediment are taken to determine the dry weight and the organic carbon content. Then, before it is used in the chironomid toxicity test, it is recommended that the formulated sediment be conditioned for seven days under the same conditions which prevail in the subsequent test.

**Storage**

The dry constituents for preparation of the artificial sediment may be stored in a dry and cool place at room temperature. The formulated (wet) sediment should not be stored prior to its use in the test. It should be used immediately after the 7 days conditioning period that ends its preparation.

**LITERATURE:**

Chapter C.8 of this Annex. Toxicity for Earthworms.

Meller M, Egeler P, Rombke J, Schallnass H, Nagel R, Streit B (1998). Short-term Toxicity of Lindane, Hexachlorobenzene and Copper Sulfate on Tubificid Sludgeworms (Oligochaeta) in Artificial Media. *Ecotox. and Environ. Safety* 39: 10-20.

## Appendix 4

**Chemical Characteristics of an Acceptable Dilution Water**

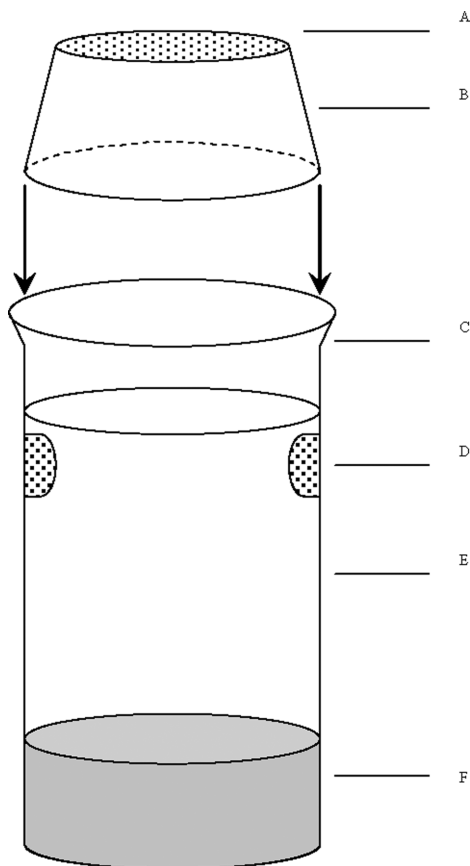
Substance	Concentrations
Particulate matter	< 20 mg/l
Total organic carbon	< 2 mg/l
Unionised ammonia	< 1 µg/l
Hardness as CaCO <sub>3</sub>	< 400 mg/l (*)
Residual chlorine	< 10 µg/l
Total organophosphorus pesticides	< 50 ng/l
Total organochlorine pesticides plus polychlorinated biphenyls	< 50 ng/l
Total organic chlorine	< 25 ng/l

(\*) However, it should be noted that if there is an interaction suspected between hardness ions and the test substance, lower hardness water should be used (and thus, Elendt Medium M4 must not be used in this situation).

## Appendix 5

**Guidance for monitoring emergence of chironomid larvae**

Emergence traps are placed on the test beakers. These traps are needed from day 20 to the end of the test. Example of trap used is drawn below:



A: the nylon screen

B: the inverted plastic cups

C: the lipless exposure beaker

D: the water exchange screen ports

E: water

F: sediment

**C. 28. SEDIMENT-WATER CHIRONOMID TOXICITY TEST USING SPIKED WATER**

## INTRODUCTION

1. This Test Method is equivalent to OECD TG 219 (2004). This Test Method is designed to assess the effects of prolonged exposure of chemicals to the sediment-dwelling larvae of the freshwater dipteran *Chironomus* sp. It is mainly based on the BBA guideline using a sediment-water test system with artificial soil, and water column exposure scenario (1). It also takes into account existing toxicity test protocols for *Chironomus riparius* and *Chironomus tentans* which have been developed in Europe and North America (2)(3)(4)(5)(6)(7)(8) and ring-tested (1)(6)(9). Other well documented chironomid species may also be used, e.g. *Chironomus yoshimatsui* (10)(11).
2. The exposure scenario used in this Test Method is water spiking. The selection of the appropriate exposure scenario depends on the intended application of the test. The water exposure scenario, involving spiking of the water column, is intended to simulate a pesticide spray drift event and covers the initial peak of concentrations in pore water. It is also useful for other types of exposure (including chemical spills) except accumulation processes lasting longer than the test period.



3. Substances that need to be tested towards sediment-dwelling organisms usually persist in this compartment over long time periods. The sediment-dwelling organisms may be exposed via a number of routes. The relative importance of each exposure route, and the time taken for each to contribute to the overall toxic effects, is dependent on the physical-chemical properties of the chemical concerned. For strongly adsorbing substances (e.g. with  $\log K_{ow} > 5$ ) or for substances covalently binding to sediment, ingestion of contaminated food may be a significant exposure route. In order not to underestimate the toxicity of highly lipophilic substances, the use of food added to the sediment before application of the test substance may be considered. In order to take all potential routes of exposure into account the focus of this Test Method is on long-term exposure. The test duration is in the range of 20-28 days for *C. riparius* and *C. yoshimatsui*, and 28-65 days for *C. tentans*. If short-term data are required for a specific purpose, for example to investigate the effects of unstable chemicals, additional replicates may be removed after a 10-day period.
4. The measured endpoints are the total number of adults emerged and the time to emergence. It is recommended that measurements of larval survival and growth should only be made after a 10-day period if additional short-term data are required, using additional replicates as appropriate.
5. The use of formulated sediment is recommended. Formulated sediment has several advantages over natural sediments:
  - the experimental variability is reduced because it forms a reproducible “standardised matrix” and the need to find uncontaminated and clean sediment sources is eliminated;
  - the tests can be initiated at any time without encountering seasonal variability in the test sediment and there is no need to pre-treat the sediment to remove indigenous fauna; the use of formulated sediment also reduces the cost associated with the field collection of sufficient amounts of sediment for routine testing;
  - the use of formulated sediment allows for comparisons of toxicity and ranking substances accordingly: toxicity data from tests with natural and artificial sediments were comparable for several chemicals (2).
6. Definitions used are given in Appendix 1.

#### PRINCIPLE OF THE TEST

7. First instar chironomid larvae are exposed to a concentration range of the test substance in sediment-water systems. The test starts by placing first instar larvae into the test beakers containing the sediment-water system and subsequently spiking the test substance into the water. Chironomid emergence and development rate is measured at the end of the test. Larval survival and weight may also be measured after 10 days if required (using additional replicates as appropriate). These data are analysed either by using a regression model in order to estimate the concentration that would cause x % reduction in emergence, larvae survival or growth (e.g.  $EC_{15}$ ,  $EC_{50}$ , etc.), or by using statistical hypothesis testing to determine a NOEC/LOEC. The latter requires comparison of effect values with control values using statistical tests.

#### INFORMATION ON THE TEST SUBSTANCE

8. The water solubility of the test substance, its vapour pressure, measured or calculated partitioning into sediment and stability in water and sediment should be known. A reliable analytical method for the quantification of the test substance in overlying water, pore water and sediment with known and reported accuracy and limit of detection should be available. Useful information includes the structural formula and purity of the test substance. Chemical fate of the test substance (e.g. dissipation, abiotic and biotic degradation, etc.) also is useful information. Further guidance for testing substances with physical-chemical properties that make them difficult to perform the test is provided in (12).

#### REFERENCE CHEMICALS

9. Reference chemicals may be tested periodically as a means of assuring that the test protocol and test conditions are reliable. Examples of reference toxicants used successfully in ring-tests and validation studies are: lindane, trifluralin, pentachlorophenol, cadmium chloride and potassium chloride. (1)(2)(5)(6)(13).

#### VALIDITY OF THE TEST

10. For the test to be valid the following conditions apply:
  - the emergence in the controls must be at least 70 % at the end of the test. (1)(6);

- *C. riparius* and *C. yoshimatsui* emergence to adults from control vessels should occur between 12 and 23 days after their insertion into the vessels; for *C. tentans*, a period of 20 to 65 days is necessary.
  
- at the end of the test, pH and the dissolved oxygen concentration should be measured in each vessel. The oxygen concentration should be at least 60 % of the air saturation value (ASV) at the temperature used, and the pH of overlying water should be in the 6-9 range in all test vessels;
  
- the water temperature should not differ by more than  $\pm 1,0$  °C. The water temperature could be controlled by isothermal room and in that case the room temperature should be confirmed in an appropriate time intervals.

#### DESCRIPTION OF THE METHOD

##### Test vessels

11. The study is conducted in glass 600 ml beakers measuring 8 cm in diameter. Other vessels are suitable, but they should guarantee a suitable depth of overlying water and sediment. The sediment surface should be sufficient to provide 2 to 3 cm<sup>2</sup> per larvae. The ratio of the depth of the sediment layer to the depth of the overlying water should be 1:4. Test vessels and other apparatus that will come into contact with the test system should be made entirely of glass or other chemically inert material (e.g. Teflon).

##### Selection of species

12. The species to be used in the test is preferably *Chironomus riparius*. *Chironomus tentans* is also suitable but more difficult to handle and requires a longer test period. *Chironomus yohimatsui* may also be used. Details of culture methods are given in Appendix 2 for *Chironomus riparius*. Information on culture conditions is also available for other species, i.e. *Chironomus tentans* (4) and *Chironomus yoshimatsui* (11). Identification of species must be confirmed before testing but is not required prior to every test if organisms come from an in-house culture.

##### Sediment

13. Formulated sediment (also called reconstituted, artificial or synthetic sediment) should preferably be used. However, if natural sediment is used, it should be characterised (at least pH, organic carbon content, determination of other parameters such as C/N ratio and granulometry are also recommended), and it should be free from any contamination and other organisms that might compete with, or consume the chironomids. It is also recommended that, before it is used in a chironomid toxicity test, the natural sediment be conditioned for seven days under the same conditions which prevail in the subsequent test. The following formulated sediment, based on the artificial soil used in Test Method C.8 (14), is recommended for use in this test (1)(15)(16):
  - a) 4-5 % (dry weight) peat: as close to pH 5,5 to 6,0 as possible; it is important to use peat in powder form, finely ground (particle size  $\leq 1$  mm) and only air dried.
  - b) 20 % (dry weight) kaolin clay (kaolinite content preferably above 30 %).
  - c) 75-76 % (dry weight) quartz sand (fine sand should predominate with more than 50 % of the particles between 50 and 200  $\mu$ m).
  - d) Deionised water is added to obtain moisture of the final mixture in a range of 30-50 %.
  - e) Calcium carbonate of chemically pure quality (CaCO<sub>3</sub>) is added adjust the pH of the final mixture of the sediment to 7,0  $\pm$  0,5.
  - f) Organic carbon content of the final mixture should be 2 % ( $\pm$  0,5 %) and is to be adjusted by the use of appropriate amounts of peat and sand, according to (a) and (c).
14. The source of peat, kaolin clay and sand should be known. The sediment components should be checked for the absence of chemical contamination (e.g. heavy metals, organochlorine compounds, organophosphorous compounds, etc.). An example for the preparation of the formulated sediment is described in Appendix 3. Mixing of dry constituents is also acceptable if it is demonstrated that after addition of overlying water a separation of sediment constituents (e.g. floating of peat particles) does not occur, and that the peat or the sediment is sufficiently conditioned.

### Water

15. Any water which conforms to the chemical characteristics of acceptable dilution water as listed in Appendices 2 and 4 is suitable as test water. Any suitable water, natural water (surface or ground water), reconstituted water (see Appendix 2) or dechlorinated tap water are acceptable as culturing water and test water if chironomids will survive in it for the duration of the culturing and testing without showing signs of stress. At the start of the test, the pH of the test water should be between 6 and 9 and the total hardness not higher than 400 mg/l as CaCO<sub>3</sub>. However, if there is an interaction suspected between hardness ions and the test substance, lower hardness water should be used (and thus, Elendt Medium M4 must not be used in this situation). The same type of water should be used throughout the whole study. The water quality characteristics listed in Appendix 4 should be measured at least twice a year or when it is suspected that these characteristics may have changed significantly.

### Stock solutions — Spiked water

16. Test concentrations are calculated on the basis of water column concentrations, i.e. the water overlying the sediment. Test solutions of the chosen concentrations are usually prepared by dilution of a stock solution. Stock solutions should preferably be prepared by dissolving the test substance in test medium. The use of solvents or dispersants may be required in some cases in order to produce a suitably concentrated stock solution. Examples of suitable solvents are acetone, ethanol, methanol, ethylene glycol monoethyl ether, ethylene glycol dimethyl ether, dimethylformamide and triethylene glycol. Dispersants which may be used are Cremophor RH40, Tween 80, methylcellulose 0,01 % and HCO-40. The solubilising agent concentration in the final test medium should be minimal (i.e.  $\leq 0,1$  ml/l) and should be the same in all treatments. When a solubilising agent is used, it must have no significant effects on survival or no visible adverse effect on the chironomid larvae as revealed by a solvent-only control. However, every effort should be made to avoid the use of such materials.

### TEST DESIGN

17. The test design relates to the selection of the number and spacing of the test concentrations, the number of vessels at each concentration and the number of larvae per vessel. Designs for EC point estimation, for estimation of NOEC, and for conducting a limit test are described. The analysis by regression is preferred to the hypothesis testing approach.

#### *Design for analysis by regression*

18. The effect concentration (e.g. EC<sub>15</sub>, EC<sub>50</sub>) and the concentration range, over which the effect of the test substance is of interest, should be spanned by the concentrations included in the test. Generally, the accuracy and especially validity, with which estimates of effect concentrations (EC<sub>x</sub>) can be made, is improved when the effect concentration is within the range of concentrations tested. Extrapolation much below the lowest positive concentration or above the highest concentration should be avoided. A preliminary range-finding test is helpful for selecting the range of concentrations to be used (see paragraph 27).
19. If the EC<sub>x</sub> is to be estimated, at least five concentrations and three replicates for each concentration should be tested. In any case, it is advisable that sufficient test concentrations are used to allow a good model estimation. The factor between concentrations should not be greater than two (an exception could be made in cases when the dose response curve has a shallow slope). The number of replicates at each treatment can be reduced if the number of test concentrations with different responses is increased. Increasing the number of replicates or reducing the size of the test concentration intervals tends to lead to narrower confidence intervals for the test. Additional replicates are required if 10-day larval survival and growth are to be estimated.

#### *Design for estimation of a NOEC/LOEC*

20. If the LOEC/NOEC are to be estimated, five test concentrations with at least four replicates should be used and the factor between concentrations should not be greater than two. The number of replicates should be sufficient to ensure adequate statistical power to detect a 20 % difference from the control at the 5 % level of significance ( $p = 0,05$ ). With the development rate, an Analysis of Variance (ANOVA) is usually appropriate, such as Dunnett-test and Williams-test (17)(18)(19)(20). In the emergence ratio the Cochran-Armitage, Fisher's exact (with Bonferroni correction), or Mantel-Haenszel tests may be used.

#### *Limit test*

21. A limit test may be performed (one test concentration and control) if no effects were seen in the preliminary range-finding test. The purpose of the limit test is to indicate that the toxic value of the test substance is greater than the limit concentration tested. No suggestion for a recommended concentration can be made in this Test Method; this is left to the regulators' judgement. Usually, at least six replicates for both the treatment and control are necessary. Adequate statistical power to detect a 20 % difference from the control at the 5 % level of significance ( $p = 0,05$ ) should be demonstrated. With metric response (development rate and weight), the t-test is a suitable statistical method if data meet the requirements of this test (normality, homogeneous variances). The unequal-variance t-test or a non parametric test, such as the Wilcoxon-Mann-Whitney test may be used, if these requirements are not fulfilled. With the emergence ratio, the Fisher exact test is appropriate.

## PROCEDURE

**Conditions of exposure***Preparation of spiked water-sediment system*

22. Appropriate amounts of formulated sediment (see paragraphs 13-14 and Appendix 3) are added in the test vessels to form a layer of at least 1,5 cm. Water is added to a depth of 6 cm (see paragraph 15). The ratio of the depth of the sediment layer and the depth of the water should not exceed 1:4 and the sediment layer should not be deeper than 3 cm. The sediment-water system should be left under gentle aeration for seven days prior to addition of test organisms (see paragraph 14 and Appendix 3). To avoid separation of sediment ingredients and re-suspension of fine material during addition of test water in the water column, the sediment can be covered with a plastic disc while water is poured onto it, and the disc is removed immediately afterwards. Other devices may also be appropriate.
23. The test vessels should be covered (e.g. by glass plates). If necessary, during the study the water levels will be topped to the original volume in order to compensate for water evaporation. This should be performed using distilled or deionised water to prevent build-up of salts.

*Addition of test organisms*

24. Four to five days before adding the test organisms to the test vessels, egg masses should be taken from the cultures and placed in small vessels in culture medium. Aged medium from the stock culture or freshly prepared medium may be used. If the latter is used, a small amount of food e.g. green algae and/or a few droplets of filtrate from a finely ground suspension of flaked fish food should be added to the culture medium (see Appendix 2). Only freshly laid egg masses should be used. Normally, the larvae begin to hatch a couple of days after the eggs are laid (2 to 3 days for *Chironomus riparius* at 20 °C and 1 to 4 days for *Chironomus tentans* at 23 °C and *Chironomus yoshimatui* at 25 °C) and larval growth occurs in four instars, each of 4-8 days duration. First instar larvae (2-3 or 1-4 days post hatching) should be used in the test. The instar of midges can possibly be checked using head capsule width (6).
25. Twenty first instar larvae are allocated randomly to each test vessel containing the spiked sediment and water, using a blunt pipette. Aeration of the water has to be stopped while adding the larvae to test vessels and remain so for another 24 hours after addition of larvae (see paragraphs 24 and 32). According to the test design used (see paragraphs 19 and 20), the number of larvae used per concentration is at least 60 for the EC point estimation and 80 for determination of NOEC.
26. Twenty-four hours after adding the larvae, the test substance is spiked into the overlying water column, and slight aeration is again supplied. Small volumes of test substance solutions are applied below the surface of the water using a pipette. The overlying water should then be mixed with care not to disturb the sediment.

*Test concentrations*

27. A range-finding test may be helpful to determine the range of concentrations for the definitive test. For this purpose a series of widely spaced concentrations of the test substance are used. In order to provide the same density of surface per chironomids, which is to be used for the definitive test, chironomids are exposed to each concentration of the test substance for a period which allows estimation of appropriate test concentrations, and no replicates are required.
28. The test concentrations for the definitive test are decided based on the result of the range-finding test. At least five concentrations should be used and selected as described in paragraphs 18 to 20.

*Controls*

29. Control vessels without any test substance but including sediment should be included in the test with the appropriate number of replicates (see paragraphs 19-20). If a solvent has been used for application of test substance (see paragraph 16), a sediment solvent control should be added.

*Test system*

30. Static systems are used. Semi-static or flow-through systems with intermittent or continuous renewal of overlying water might be used in exceptional cases as for instance if water quality specifications become inappropriate for the test organism or affect chemical equilibrium (e.g. dissolved oxygen levels fall too low, the concentration of excretory products rises too high or minerals leach from sediment and affect pH and/or water hardness). However, other methods for ameliorating the quality of overlying water, such as aeration, will normally suffice and be preferable.

#### Food

31. It is necessary to feed the larvae, preferably daily or at least three times per week. Fish-food (a suspension in water or finely ground food, e.g. TetraMin or TetraPhyll; see details in Appendix 2) in the amount of 0,25-0,5 mg (0,35-0,5 mg for *C. yoshimatui*) per larvae per day seems adequate for young larvae for the first 10 days. Slightly more food may be necessary for older larvae: 0,5-1 mg per larvae per day should be sufficient for the rest of the test. The food ration should be reduced in all treatments and control if fungal growth is seen or if mortality is observed in controls. If fungal development cannot be stopped the test is to be repeated. When testing strongly adsorbing substances (e.g. with  $\log K_{ow} > 5$ ), or substances covalently binding to sediment, the amount of food necessary to ensure survival and natural growth of the organisms may be added to the formulated sediment before the stabilisation period. For this, plant material must be used instead of fish food, e.g. addition of 0,5 % (dry weight) finely ground leaves of e.g. stinging nettle (*Urtica dioica*), mulberry (*Morus alba*), white clover (*Trifolium repens*), spinach (*Spinacia oleracea*) or of other plant material (*Cerophyl* or alpha-cellulose) may be used.

#### Incubation conditions

32. Gentle aeration of the overlying water in test vessels is supplied preferably 24 hours after addition of the larvae and is pursued throughout the test (care should be taken that dissolved oxygen concentration does not fall below 60 % of ASV). Aeration is provided through a glass Pasteur pipette fixed 2-3 cm above the sediment layer (i.e. one or few bubbles/sec). When testing volatile chemicals, consideration may be given not to aerate the sediment-water system.
33. The test is conducted at a constant temperature of 20 °C ( $\pm 2$  °C). For *C. tentans* and *C. yoshimatui*, recommended temperatures are of 23 °C and 25 °C ( $\pm 2$  °C), respectively. A 16 hours photoperiod is used and the light intensity should be 500 to 1 000 lux.

#### Exposure duration

34. The exposure commences with the addition of larvae to the spiked and control vessels. The maximum exposure duration is 28 days for *C. riparius* and *C. yoshimatsui*, and 65 days for *C. tentans*. If midges emerge earlier, the test can be terminated after a minimum of five days after emergence of the last adult in the control.

#### OBSERVATIONS

##### Emergence

35. The development time and the total number of fully emerged male and female midges are determined. Males are easily identified by their plumose antennae.
36. The test vessels should be observed at least three times per week to make visual assessment of any abnormal behaviour (e.g. leaving sediment, unusual swimming), compared with the control. During the period of expected emergence a daily count of emerged midges is necessary. The sex and number of fully emerged midges are recorded daily. After identification the midges are removed from the vessels. Any egg masses deposited prior to the termination of the test should be recorded and then removed to prevent re-introduction of larvae into the sediment. The number of visible pupae that have failed to emerge is also recorded. Guidance on measurement of emergence is provided in Appendix 5.

##### Growth and survival

37. If data on 10-day larval survival and growth are to be provided, additional test vessels should be included at the start, so that they may be used subsequently. The sediment from these additional vessels is sieved using a 250  $\mu\text{m}$  sieve to retain the larvae. Criteria for death are immobility or lack of reaction to a mechanical stimulus. Larvae not recovered should also be counted as dead (larvae which have died at beginning of the test may have been degraded by microbes). The (ash free) dry weight of the surviving larvae per test vessel is determined and the mean individual dry weight per vessel calculated. It is useful to determine which instar the surviving larvae belong to; for that measurement of the width of the head capsule of each individual can be used.

#### Analytical measurements

##### Concentration of the test substance

38. As a minimum, samples of the overlying water, the pore water and the sediment must be analysed at the start (preferably one hour after application of test substance) and at the end of the test, at the highest concentration and a lower one. These determinations of test substance concentration inform on the behaviour/partitioning of the test substance in the water-sediment system. Sampling of sediment at the start of the test may influence the

test system (e.g. removing test larvae), thus additional test vessels should be used to perform analytical determinations at the start and during the test if appropriate (see paragraph 39). Measurements in sediment might not be necessary if the partitioning of the test substance between water and sediment has been clearly determined in a water/sediment study under comparable conditions (e.g. sediment to water ratio, type of application, organic carbon content of sediment).

39. When intermediate measurements are made (e.g. at day 7) and if the analysis needs large samples which cannot be taken from test vessels without influencing the test system, analytical determinations should be performed on samples from additional test vessels treated in the same way (including the presence of test organisms) but not used for biological observations.
40. Centrifugation at e.g. 10 000 g and 4 °C for 30 min. is the recommended procedure to isolate interstitial water. However, if the test substance is demonstrated not to adsorb to filters, filtration may also be acceptable. In some cases it might not be possible to analyse concentrations in the pore water as the sample size is too small.

#### *Physical-chemical parameters*

41. The pH, dissolved oxygen in the test water and temperature of the test vessels should be measured in an appropriate manner (see paragraph 10). Hardness and ammonia should be measured in the controls and one test vessel at the highest concentration at the start and the end of the test.

#### DATA AND REPORTING

##### *Treatment of results*

42. The purpose of this test is to determine the effect of the test substance on the development rate and the total number of fully emerged male and female midges, or in the case of the 10-day test effects on survival and weight of the larvae. If there are no indications of statistically different sensitivities of sexes, male and female results may be pooled for statistical analyses. The sensitivity differences between sexes can be statistically judged by e.g. a  $\chi^2$ -r × 2 table test. Larval survival and mean individual dry weight per vessel must be determined after 10 days where required.
43. Effect concentrations expressed as concentrations in the overlaying water, are calculated preferably based on measured concentrations at the beginning of the test (see paragraph 38).
44. To compute a point estimate for the EC<sub>50</sub> or any other EC<sub>x</sub>, the per-vessel statistics may be used as true replicates. In calculating a confidence interval for any EC<sub>x</sub> the variability among vessels should be taken into account, or it should be shown that this variability is so small that it can be ignored. When the model is fitted by Least Squares, a transformation should be applied to the per-vessel statistics in order to improve the homogeneity of variance. However, EC<sub>x</sub> values should be calculated after the response is transformed back to the original value.
45. When the statistical analysis aims at determining the NOEC/LOEC by hypothesis testing, the variability among vessels needs to be taken into account, e.g. by a nested ANOVA. Alternatively, more robust tests (21) can be appropriate in situations where there are violations of the usual ANOVA assumptions.

##### *Emergence ratio*

46. Emergence ratios are quantal data, and can be analyzed by the Cochran-Armitage test applied in step-down manner where a monotonic dose-response is expected and these data are consistent with this expectation. If not, a Fisher's exact or Mantel-Haenszel test with Bonferroni-Holm adjusted p-values can be used. If there is evidence of greater variability between replicates within the same concentration than a binomial distribution would indicate (often referenced as "extra-binomial" variation), then a robust Cochran-Armitage or Fisher exact test such as proposed in (21), should be used.
47. The sum of midges emerged per vessel,  $n_e$ , is determined and divided by the number of larvae introduced,  $n_a$ :

$$ER = \frac{n_e}{n_a}$$

where:

ER = emergence ratio

$n_e$  = number of midges emerged per vessel

$n_a$  = number of larvae introduced per vessel



48. An alternative that is most appropriate for large sample sizes, when there is extra binomial variance, is to treat the emergence ratio as a continuous response and use procedures such as William's test when a monotonic dose-response is expected and is consistent with these ER data. Dunnett's test would be appropriate where monotonicity does not hold. A large sample size is defined here as the number emerged and the number not emerging both exceeding five, on a per replicate (vessel) basis.
49. To apply ANOVA methods values of ER should first be transformed by the arcsin square root transformation or Freeman-Tukey transformation to obtain an approximate normal distribution and to equalise variances. The Cochran-Armitage, Fisher's exact (Bonferroni), or Mantel-Haenszel tests can be applied when using the absolute frequencies. The arcsin square root transformation is applied by taking the inverse sine ( $\text{sine}^{-1}$ ) of the square root of ER.
50. For emergence ratios,  $EC_x$ -values are calculated using regression analysis (or e.g. probit (22), logit, Weibull, appropriate commercial software etc.). If regression analysis fails (e.g. when there are less than two partial responses), other non-parametric methods such as moving average or simple interpolation are used.

#### *Development rate*

51. The mean development time represents the mean time span between the introduction of larvae (day 0 of the test) and the emergence of the experimental cohort of midges. (For the calculation of the true development time, the age of larvae at the time of introduction should be considered). The development rate is the reciprocal of the development time (unit: 1/day) and represents that portion of larval development which takes place per day. The development rate is preferred for the evaluation of these sediment toxicity studies as its variance is lower, and it is more homogeneous and closer to normal distribution as compared to development time. Hence, powerful parametric test procedures may be used with development rate rather than with development time. For development rate as a continuous response,  $EC_x$ -values can be estimated by using regression analysis (e.g. (23)(24)).
52. For the following statistical tests, the number of midges observed on inspection day  $x$  are assumed to be emerged at the mean of the time interval between day  $x$  and day  $x - 1$  ( $l$  = length of the inspection interval, usually 1 day). The mean development rate per vessel ( $\bar{x}$ ) is calculated according to:

$$\bar{x} = \sum_{i=1}^m \frac{f_i x_i}{n_e}$$

where:

- $\bar{x}$ : mean development rate per vessel
- $i$ : index of inspection interval
- $m$ : maximum number of inspection intervals
- $f_i$ : number of midges emerged in the inspection interval  $i$
- $n_e$ : total number of midges emerged at the end of experiment ( $= \sum f_i$ )
- $x_i$ : development rate of the midges emerged in interval  $i$

$$x_i = 1 / \left( \text{day}_i - \frac{l_i}{2} \right)$$

where:

- $\text{day}_i$ : inspection day (days since application)
- $l_i$ : length of inspection interval  $i$  (days, usually 1 day)

#### **Test report**

53. *The test report must at least provide the following information:*

##### *Test substance:*

- physical nature and, where relevant, physical-chemical properties (water solubility, vapour pressure, partition coefficient in soil (or in sediment if available), stability in water, etc.);
- chemical identification data (common name, chemical name, structural formula, CAS number, etc.) including purity and analytical method for quantification of test substance.

*Test species:*

- test animals used: species, scientific name, source of organisms and breeding conditions;
- information on handling of egg masses and larvae;
- age of test animals when inserted into test vessels.

*Test conditions:*

- sediment used, i.e. natural or formulated sediment;
- for natural sediment, location and description of sediment sampling site, including, if possible, contamination history; characteristics: pH, organic carbon content, C/N ratio and granulometry (if appropriate).
- preparation of the formulated sediment: ingredients and characteristics (organic carbon content, pH, moisture, etc. at the start of the test);
- preparation of the test water (if reconstituted water is used) and characteristics (oxygen concentration, pH, conductivity, hardness, etc. at the start of the test);
- depth of sediment and overlying water;
- volume of overlying and pore water; weight of wet sediment with and without pore water;
- test vessels (material and size);
- method of preparation of stock solutions and test concentrations;
- application of test substance: test concentrations used, number of replicates and use of solvent if any;
- incubation conditions: temperature, light cycle and intensity, aeration (frequency and intensity);
- detailed information on feeding including type of food, preparation, amount and feeding regime.

*Results:*

- the nominal test concentrations, the measured test concentrations and the results of all analyses to determine the concentration of the test substance in the test vessel;
- water quality within the test vessels, i.e. pH, temperature, dissolved oxygen, hardness and ammonia;
- replacement of evaporated test water, if any;
- number of emerged male and female midges per vessel and per day;
- number of larvae which failed to emerge as midges per vessel;
- mean individual dry weight of larvae per vessel, and per instar, if appropriate;
- percent emergence per replicate and test concentration (male and female midges pooled);
- mean development rate of fully emerged midges per replicate and treatment rate (male and female midges pooled);
- estimates of toxic endpoints e.g.  $EC_x$  (and associated confidence intervals), NOEC and/or LOEC, and the statistical methods used for their determination;
- discussion of the results, including any influence on the outcome of the test resulting from deviations from this Test Method.



## LITERATURE:

- (1) BBA (1995). Long-term toxicity test with *Chironomus riparius*: Development and validation of a new test system. Edited by M. Streløkke and H. Köpp. Berlin 1995.
- (2) Fleming R *et al.* (1994). Sediment Toxicity Tests for Poorly Water-Soluble Substances. Final Report to the European Commission. Report No: EC 3738. August 1994. WRc, UK.
- (3) SETAC (1993). Guidance Document on Sediment toxicity Tests and Bioassays for Freshwater and Marine Environments. From the WOSTA Workshop held in the Netherlands.
- (4) ASTM International/E1706-00 (2002). Test Method for Measuring the Toxicity of Sediment-Associated Contaminants with Freshwater Invertebrates. pp 1125-1241. In ASTM International 2002 Annual Book of Standards. Volume 11.05. Biological Effects and Environmental Fate; Biotechnology; Pesticides. ASTM International, West Conshohocken, PA.
- (5) Environment Canada (1997). Test for Growth and Survival in Sediment using Larvae of Freshwater Midges (*Chironomus tentans* or *Chironomus riparius*). Biological Test Method. Report SPE 1/RM/32. December 1997.
- (6) US-EPA (2000). Methods for Measuring the Toxicity and Bioaccumulation of Sediment-associated Contaminants with Freshwater Invertebrates. Second edition. EPA 600/R-99/064. March 2000. Revision to the first edition dated June 1994.
- (7) US-EPA/OPPTS 850.1735. (1996): Whole Sediment Acute Toxicity Invertebrates.
- (8) US-EPA/OPPTS 850.1790. (1996): Chironomid Sediment toxicity Test.
- (9) Milani D, Day KE, McLeay DJ, Kirby RS (1996). Recent intra- and inter-laboratory studies related to the development and standardisation of Environment Canada's biological test methods for measuring sediment toxicity using freshwater amphipods (*Hyalella azteca*) and midge larvae (*Chironomus riparius*). Technical Report. Environment Canada. National Water Research Institute. Burlington, Ontario, Canada.
- (10) Sugaya Y (1997). Intra-specific variations of the susceptibility of insecticides in *Chironomus yoshimatsui*. Jp. J. Sanit. Zool. 48 (4): 345-350.
- (11) Kawai K (1986). Fundamental studies on Chironomid allergy. I. Culture methods of some Japanese Chironomids (Chironomidae, Diptera). Jp. J. Sanit. Zool. 37(1): 47-57.
- (12) OECD (2000). Guidance Document on Aquatic Toxicity Testing of Difficult Substances and Mixtures. OECD Environment, Health and Safety Publications, Series on Testing and Assessment No 23.
- (13) Environment Canada (1995). Guidance Document on Measurement of Toxicity Test Precision Using Control Sediments Spiked with a Reference Toxicant. Report EPS 1/RM/30. September 1995.
- (14) Chapter C.8 of this Annex, Toxicity for Earthworms,
- (15) Suedel BC and Rodgers JH (1994). Development of formulated reference sediments for freshwater and estuarine sediment testing. Environ. Toxicol. Chem. 13: 1163-1175.
- (16) Naylor C and Rodrigues C (1995). Development of a test method for *Chironomus riparius* using a formulated sediment. Chemosphere 31: 3291-3303.
- (17) Dunnett CW (1964). A multiple comparisons procedure for comparing several treatments with a control. J. Amer. Statist. Assoc. 50: 1096-1121.

- 
- (18) Dunnett CW (1964). New tables for multiple comparisons with a control. *Biometrics* 20: 482-491.
  - (19) Williams DA (1971). A test for differences between treatment means when several dose levels are compared with a zero dose control. *Biometrics* 27: 103-117.
  - (20) Williams DA (1972). The comparison of several dose levels with a zero dose control. *Biometrics* 28: 510-531.
  - (21) Rao JNK and Scott AJ (1992). A simple method for the analysis of clustered binary data. *Biometrics* 48: 577-585.
  - (22) Christensen ER (1984). Dose-response functions in aquatic toxicity testing and the Weibull model. *Water Research* 18: 213-221.
  - (23) Bruce and Versteeg (1992). A statistical procedure for modelling continuous toxicity data. *Environmental Toxicology and Chemistry* 11:1485-1494.
  - (24) Slob W (2002). Dose-response modelling of continuous endpoints. *Toxicol. Sci.* 66: 298-312.
-

*Appendix 1*

## DEFINITIONS

For the purpose of this method the following definitions are used:

**Formulated sediment** or reconstituted, artificial or synthetic sediment, is a mixture of materials used to mimic the physical components of a natural sediment.

**Overlying water** is the water placed over sediment in the test vessel.

**Interstitial water** or pore water is the water occupying space between sediment and soil particles.

**Spiked water** is the test water to which test substance has been added.

**Test chemical:** Any substance or mixture tested using this Test Method.

---

## Appendix 2

**Recommendations for culture of *Chironomus riparius***

1. *Chironomus* larvae may be reared in crystallising dishes or larger containers. Fine quartz sand is spread in a thin layer of about 5 to 10 mm deep over the bottom of the container. Kieselguhr (e.g. Merck, Art 8117) has also been shown to be a suitable substrate (a thinner layer of up to a very few mm is sufficient). Suitable water is then added to a depth of several cm. Water levels should be topped up as necessary to replace evaporative loss, and prevent desiccation. Water can be replaced if necessary. Gentle aeration should be provided. The larval rearing vessels should be held in a suitable cage which will prevent escape of the emerging adults. The cage should be sufficiently large to allow swarming of emerged adults, otherwise copulation may not occur (minimum is ca. 30 × 30 × 30 cm).
2. Cages should be held at room temperature or in a constant environment room at 20 ± 2 °C with a photo period of 16 hour light (intensity ca. 1 000 lux), 8 hours dark. It has been reported that air humidity of less than 60 % RH can impede reproduction.

**Dilution water**

3. Any suitable natural or synthetic water may be used. Well water, dechlorinated tap water and artificial media (e.g. Elendt "M4" or "M7" medium, see below) are commonly used. The water has to be aerated before use. If necessary, the culture water may be renewed by pouring or siphoning the used water from culture vessels carefully without destroying the tubes of larvae.

**Feeding larvae**

4. *Chironomus* larvae should be fed with a fish flake food (TetraMin<sup>®</sup>, TetraPhyll<sup>®</sup> or other similar brand of proprietary fish food), at approximately 250 mg per vessel per day. This can be given as a dry ground powder or as a suspension in water: 1,0 g of flake food is added to 20 ml of dilution water and blended to give a homogenous mix. This preparation may be fed at a rate of about 5 ml per vessel per day (shake before use.) Older larvae may receive more.
5. Feeding is adjusted according to the water quality. If the culture medium becomes "cloudy", the feeding should be reduced. Food additions must be carefully monitored. Too little food will cause emigration of the larvae towards the water column, and too much food will cause increased microbial activity and reduced oxygen concentrations. Both conditions can result in reduced growth rates.
6. Some green algae (e.g. *Scenedesmus subspicatus*, *Chlorella vulgaris*) cells may also be added when new culture vessels are set up.

**Feeding emerged adults**

7. Some experimenters have suggested that a cotton wool pad soaked in a saturated sucrose solution may serve as a food for emerged adults.

**Emergence**

8. At 20 ± 2 °C adults will begin to emerge from the larval rearing vessels after approximately 13-15 days. Males are easily distinguished by having plumose antennae.

**Egg masses**

9. Once adults are present within the breeding cage, all larval rearing vessels should be checked three times weekly for deposition of the gelatinous egg masses. If present, the egg masses should be carefully removed. They should be transferred to a small dish containing a sample of the breeding water. Egg masses are used to start a new culture vessel (e.g. 2-4 egg masses/vessel) or are used for toxicity tests.
10. First instar larvae should hatch after 2-3 days.

**Set-up of new culture vessels**

11. Once cultures are established it should be possible to set up a fresh larval culture vessel weekly or less frequently depending on testing requirements, removing the older vessels after adult midges have emerged. Using this system a regular supply of adults will be produced with a minimum of management.

### Preparation of test solutions “M4” and “M7”

12. Elenđt (1990) has described the “M4” medium. The “M7” medium is prepared as the “M4” medium except for the substances indicated in Table 1, for which concentrations are four times lower in “M7” than in “M4”. A publication on the “M7” medium is in preparation (Elenđt, personal communication). The test solution should not be prepared according to Elenđt and Bias (1990) for the concentrations of NaSiO<sub>3</sub> · 5 H<sub>2</sub>O, NaNO<sub>3</sub>, KH<sub>2</sub>PO<sub>4</sub> and K<sub>2</sub>HPO<sub>4</sub> given for the preparation of the stock solutions are not adequate.

### Preparation of the “M7”-medium

13. Each stock solution (I) is prepared individually and a combined stock solution (II) is prepared from these stock solutions (I) (see Table 1). 50 ml from the combined stock Solution (II) and the amounts of each macro nutrient stock solution which are given in Table 2 are made up to 1 l of deionised water to prepare the “M7” medium. A vitamin stock solution is prepared by adding three vitamins to deionised water as indicated in Table 3, and 0,1 ml of the combined vitamin stock solution are added to the final “M7” medium shortly before use. (The vitamin stock solution is stored frozen in small aliquots). The medium is aerated and stabilised.

Table 1

#### Stock solutions of trace elements for medium M4 and M7

Stock solutions (I)	Amount (mg) made up to 1 litre of deionised water	To prepare the combined stock solution (II): mix the following amounts (ml) of stock solutions (I) and make up to 1 litre of deionised water		Final concentrations in test solutions (mg/l)	
		M4	M7	M4	M7
H <sub>3</sub> BO <sub>3</sub> <sup>(1)</sup>	57 190	1,0	0,25	2,86	0,715
MnCl <sub>2</sub> · 4 H <sub>2</sub> O <sup>(1)</sup>	7 210	1,0	0,25	0,361	0,090
LiCl <sup>(1)</sup>	6 120	1,0	0,25	0,306	0,077
RbCl <sup>(1)</sup>	1 420	1,0	0,25	0,071	0,018
SrCl <sub>2</sub> · 6 H <sub>2</sub> O <sup>(1)</sup>	3 040	1,0	0,25	0,152	0,038
NaBr <sup>(1)</sup>	320	1,0	0,25	0,016	0,004
Na <sub>2</sub> MoO <sub>4</sub> · 2 H <sub>2</sub> O <sup>(1)</sup>	1 260	1,0	0,25	0,063	0,016
CuCl <sub>2</sub> · 2 H <sub>2</sub> O <sup>(1)</sup>	335	1,0	0,25	0,017	0,004
ZnCl <sub>2</sub>	260	1,0	1,0	0,013	0,013
CaCl <sub>2</sub> · 6 H <sub>2</sub> O	200	1,0	1,0	0,010	0,010
KI	65	1,0	1,0	0,0033	0,0033
Na <sub>2</sub> SeO <sub>3</sub>	43,8	1,0	1,0	0,0022	0,0022
NH <sub>4</sub> VO <sub>3</sub>	11,5	1,0	1,0	0,00058	0,00058
Na <sub>2</sub> EDTA · 2 H <sub>2</sub> O <sup>(1)</sup> <sup>(2)</sup>	5 000	20,0	5,0	2,5	0,625
FeSO <sub>4</sub> · 7 H <sub>2</sub> O <sup>(1)</sup> <sup>(2)</sup>	1 991	20,0	5,0	1,0	0,249

<sup>(1)</sup> These substances differ in M4 and M7, as indicated above.

<sup>(2)</sup> These solutions are prepared individually, then poured together and autoclaved immediately.

Table 2

#### Macro nutrient stock solutions for medium M4 and M7

	Amount made up to 1 litre of deionised water (mg)	Amount of macro nutrient stock solutions added to prepare medium M4 and M7 (ml/l)	Final concentrations in test solutions M4 and M7 (mg/l)
CaCl <sub>2</sub> · 2 H <sub>2</sub> O	293 800	1,0	293,8
MgSO <sub>4</sub> · 7 H <sub>2</sub> O	246 600	0,5	123,3

	Amount made up to 1 litre of deionised water (mg)	Amount of macro nutrient stock solutions added to prepare medium M4 and M7 (ml/l)	Final concentrations in test solutions M4 and M7 (mg/l)
KCl	58 000	0,1	5,8
NaHCO <sub>3</sub>	64 800	1,0	64,8
NaSiO <sub>3</sub> · 9 H <sub>2</sub> O	50 000	0,2	10,0
NaNO <sub>3</sub>	2 740	0,1	0,274
KH <sub>2</sub> PO <sub>4</sub>	1 430	0,1	0,143
K <sub>2</sub> HPO <sub>4</sub>	1 840	0,1	0,184

Table 3

**Vitamin stock solution for medium M4 and M7**

All three vitamin solutions are combined to make a single vitamin stock solution.

	Amount made up to 1 litre of deionised water (mg)	Amount of vitamin stock solution added to prepare medium M4 and M7 (ml/l)	Final concentrations in test solutions M4 and M7 (mg/l)
Thiamine hydrochloride	750	0,1	0,075
Cyanocobalamin (B12)	10	0,1	0,0010
Biotine	7,5	0,1	0,00075

**LITERATURE:**

BBA (1995). Long-term toxicity test with *Chironomus riparius*: Development and validation of a new test system. Edited by M. Streloke and H.Köpp. Berlin 1995.

Elendt BP (1990). Selenium Deficiency in Crustacean. *Protoplasma* 154: 25-33.

Elendt BP and Bias W-R (1990). Trace Nutrient Deficiency in *Daphnia magna* Cultured in Standard Medium for Toxicity Testing. Effects on the Optimization of Culture Conditions on Life History Parameters of *D. magna*. *Water Research* 24 (9): 1157-1167.

## Appendix 3

## PREPARATION OF FORMULATED SEDIMENT

**Sediment composition**

The composition of the formulated sediment should be as follows:

Constituent	Characteristics	% of sediment dry weight
Peat	Sphagnum moss peat, as close to pH 5,5-6,0 as possible, no visible plant remains, finely ground (particle size $\leq$ 1 mm) and air dried	4-5
Quartz sand	Grain size: > 50 % of the particles should be in the range of 50-200 $\mu$ m	75-76
Kaolinite clay	Kaolinite content $\geq$ 30 %	20
Organic carbon	Adjusted by addition of peat and sand	2 ( $\pm$ 0,5)
Calcium carbonate	CaCO <sub>3</sub> , pulverised, chemically pure	0,05-0,1
Water	Conductivity $\leq$ 10 $\mu$ S/cm	30-50

**Preparation**

The peat is air dried and ground to a fine powder. A suspension of the required amount of peat powder in deionised water is prepared using a high-performance homogenising device. The pH of this suspension is adjusted to  $5,5 \pm 0,5$  with CaCO<sub>3</sub>. The suspension is conditioned for at least two days with gentle stirring at  $20 \pm 2$  °C, to stabilise pH and establish a stable microbial component. pH is measured again and should be  $6,0 \pm 0,5$ . Then the peat suspension is mixed with the other constituents (sand and kaolin clay) and deionised water to obtain a homogeneous sediment with a water content in a range of 30-50 per cent of dry weight of the sediment. The pH of the final mixture is measured once again and is adjusted to 6,5 to 7,5 with CaCO<sub>3</sub> if necessary. Samples of the sediment are taken to determine the dry weight and the organic carbon content. Then, before it is used in the chironomid toxicity test, it is recommended that the formulated sediment be conditioned for seven days under the same conditions which prevail in the subsequent test.

**Storage**

The dry constituents for preparation of the artificial sediment may be stored in a dry and cool place at room temperature. The formulated (wet) sediment should not be stored prior to its use in the test. It should be used immediately after the 7 days conditioning period that ends its preparation.

**LITERATURE:**

Chapter C.8 of this Annex, Toxicity for Earthworms

Meller M, Egeler P, Rombke J, Schallnass H, Nagel R and Streit B (1998). Short-term Toxicity of Lindane, Hexachlorobenzene and Copper Sulfate on Tubificid Sludgeworms (Oligochaeta) in Artificial Media. *Ecotox. and Environ. Safety* 39: 10-20.

## Appendix 4

**Chemical Characteristics of Acceptable Dilution Water**

Substance	Concentrations
Particulate matter	< 20 mg/l
Total organic carbon	< 2 mg/l
Unionised ammonia	< 1 µg/l
Hardness as CaCO <sub>3</sub>	< 400 mg/l (*)
Residual chlorine	< 10 µg/l
Total organophosphorus pesticides	< 50 ng/l
Total organochlorine pesticides plus polychlorinated biphenyls	< 50 ng/l
Total organic chlorine	< 25 ng/l

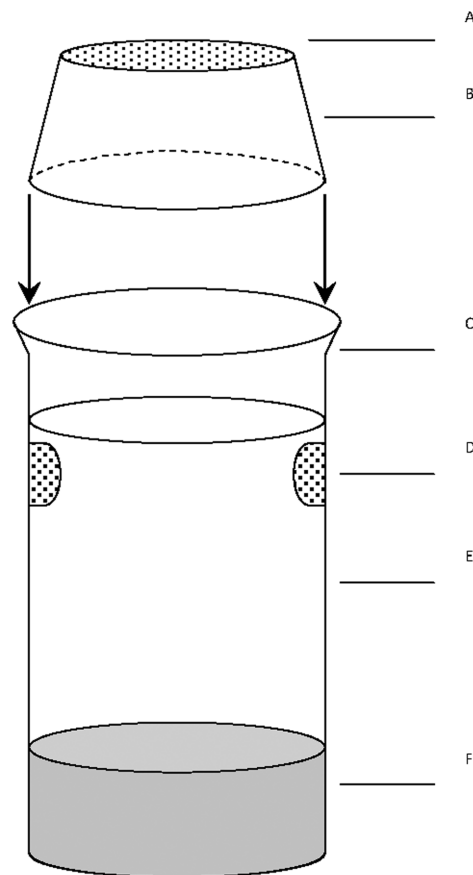
(\*) However, it should be noted that if there is an interaction suspected between hardness ions and the test substance, lower hardness water should be used (and thus, Elendt Medium M4 must not be used in this situation).



## Appendix 5

**Guidance for monitoring emergence of chironomid larvae**

Emergence traps are placed on the test beakers. These traps are needed from day 20 to the end of the test. Example of trap used is drawn below:



- |                                |                                    |
|--------------------------------|------------------------------------|
| A: the nylon screen            | D: the water exchange screen ports |
| B: the inverted plastic cups   | E: water                           |
| C: the lipless exposure beaker | F: sediment                        |

**C.29. READY BIODEGRADABILITY — CO<sub>2</sub> IN SEALED VESSELS (HEADSPACE TEST)**

## INTRODUCTION

1. This Test Method is equivalent to OECD Test Guideline (TG) 310 (2006). This Test Method is a screening method for the evaluation of ready biodegradability of chemicals and provides similar information to the six test methods described in chapter C.4 of this Annex A to F. Therefore, a chemical that shows positive results in this Test Method can be considered readily biodegradable and consequently rapidly degradable in the environment.
2. The well established carbon dioxide (CO<sub>2</sub>) method (1), based on Sturm's original test (2) for assessing biodegradability of organic chemicals, by the measurement of the carbon dioxide produced by microbial action, has normally been the first choice for testing poorly soluble chemicals and those which strongly adsorb. It is also chosen for soluble (but not volatile) chemicals, since the evolution of carbon dioxide is considered by many to be the only unequivocal proof of microbial activity. Removal of dissolved organic carbon can be effected by physico-chemical processes — adsorption, volatilisation, precipitation, hydrolysis — as well as by microbial action and many non-biological reactions consume oxygen; rarely is CO<sub>2</sub> produced from organic chemicals

abiotically. In the original and modified Sturm test (1)(2) CO<sub>2</sub> is removed from the liquid phase to the absorbing vessels by sparging (i.e. bubbling air treated to remove CO<sub>2</sub> through the liquid medium), while in the version of Larson (3)(4) CO<sub>2</sub> is transferred from the reaction vessel to the absorbers by passing CO<sub>2</sub>-free air through the headspace and, additionally, by shaking the test vessel continuously. Only in the Larson modification is the reaction vessel shaken; stirring is specified only for insoluble substances in ISO 9439 (5) and in the original US version (6), both of which specify sparging rather than headspace replacement. In another official US EPA method (7) based on Gledhill's method (8), the shaken reaction vessel is closed to the atmosphere and CO<sub>2</sub> produced is collected in an internal alkaline trap directly from the gaseous phase, as in classical Warburg/Barcroft respirometer flasks.

3. However, inorganic carbon (IC) has been shown to accumulate in the medium during the application of the standard, modified Sturm test to a number of chemicals (9). A concentration of IC as high as 8 mg/l was found during the degradation of 20 mg C/l of aniline. Thus, the collection of CO<sub>2</sub> in the alkaline traps did not give a true reflection of the amount of CO<sub>2</sub> produced microbiologically at intermediate times during the degradation. As a result, the specification that > 60 % theoretical maximum CO<sub>2</sub> production (ThCO<sub>2</sub>) must be collected within a "10-d window" (the 10 days immediately following the attainment of 10 % biodegradation) for a test chemical to be classified as readily biodegraded will not be met for some chemicals which would be so classified using dissolved organic carbon (DOC) removal.
4. When the percentage degradation is a lower value than expected, IC is possibly accumulated in the test solution. Then, the degradability may be assessed with the other ready biodegradability tests.
5. Other drawbacks of the Sturm methodology (cumbersome, time-consuming, more prone to experimental error and not applicable to volatile chemicals) had earlier prompted a search for a sealed vessel technique, other than Gledhill's, rather than gas flow-through (10)(11). Boatman et al (12) reviewed the earlier methods and adopted an enclosed headspace system in which the CO<sub>2</sub> was released into the headspace at the end of incubation by acidifying the medium. CO<sub>2</sub> was measured by gas chromatography (GC)/IC analysis in automatically taken samples of the headspace but dissolved inorganic carbon (DIC) in the liquid phase was not taken into account. Also, the vessels used were very small (20 ml) containing only 10 ml of medium, which caused problems e.g. when adding the necessarily very small amounts of insoluble test chemicals, and/or there may be insufficient or no microorganisms present in the inoculated medium that are competent to degrade the test chemicals.
6. These difficulties have been overcome by the independent studies of Struijs and Stoltenkamp (13) and of Birch and Fletcher (14), the latter being inspired by their experience with apparatus used in the anaerobic biodegradation test (15). In the former method (13) CO<sub>2</sub> is measured in the headspace after acidification and equilibration, while in the latter (14) DIC in both the gaseous and liquid phases was measured, without treatment; over 90 % of the IC formed was present in the liquid phase. Both methods had advantages over the Sturm test in that the test system was more compact and manageable, volatile chemicals can be tested and the possibility of delay in measuring CO<sub>2</sub> produced is avoided.
7. The two approaches were combined in the ISO Headspace CO<sub>2</sub> Standard (16), which was ring-tested (17) and it is this Standard which forms the basis of the present Test Method. Similarly, the two approaches have been used in the US EPA method (18). Two methods of measuring CO<sub>2</sub> have been recommended, namely CO<sub>2</sub> in headspace after acidification (13) and IC in the liquid phase after the addition of excess alkali. The latter method was introduced by Peterson during the CONCAWE ring test (19) of this headspace method modified to measure inherent biodegradability. The changes made in the 1992 (20) revision of the methods in chapter C.4 of this Annex for Ready Biodegradability have been incorporated into this Test Method, so that the conditions (medium, duration etc.) are otherwise the same as those in the revised Sturm test (20). Birch and Fletcher (14) have shown that very similar results were obtained with this headspace test as were obtained with the same chemicals in the OECD Ring Test (21) of the revised Test Methods.

#### PRINCIPLE OF THE TEST

8. The test chemical, normally at 20 mg C/l, as the sole source of carbon and energy, is incubated in a buffer-mineral salts medium which has been inoculated with a mixed population of micro-organisms. The test is performed in sealed bottles with a headspace of air, which provides a reservoir of oxygen for aerobic biodegradation. The CO<sub>2</sub> evolution resulting from the ultimate aerobic biodegradation of the test chemical is determined by measuring the IC produced in the test bottles in excess of that produced in blank vessels containing inoculated medium only. The extent of biodegradation is expressed as a percentage of the theoretical maximum IC production (ThIC), based on the quantity of test chemical (as organic carbon) added initially.
9. The DOC removal and/or the extent of primary biodegradation of the test chemical can also be measured (20).

## INFORMATION ON THE TEST CHEMICAL

10. The organic carbon content (% w/w) of the test chemical needs to be known, either from its chemical structure or by measurement, so that the percentage degradation may be calculated. For volatile test chemicals, a measured or calculated Henry's law constant is helpful for determining a suitable headspace to liquid volume ratio. Information on the toxicity of the test chemical to micro-organisms is useful in selecting an appropriate test concentration and for interpreting results showing poor biodegradability: it is recommended to include the inhibition control unless it is known that the test chemical is not inhibitory to microbial activities (see paragraph 24).

## APPLICABILITY OF THE METHOD

11. The test is applicable to water-soluble and insoluble test chemicals, though good dispersion of the test chemical should be ensured. Using the recommended headspace to liquid volume ratio of 1:2, volatile chemicals with a Henry's law constant of up to  $50 \text{ Pa}\cdot\text{m}^3\cdot\text{mol}^{-1}$  can be tested as the proportion of test chemical in the headspace will not exceed 1 % (13). A smaller headspace volume may be used when testing chemicals, which are more volatile, but their bioavailability may be limiting especially if they are poorly soluble in water. However, users must ensure that the headspace to liquid volume ratio and the test chemical concentration are such that sufficient oxygen is available to allow complete aerobic biodegradation to occur (e.g. avoid using a high substrate concentration and a small headspace volume). Guidance on this matter can be found in (13)(23).

## REFERENCE CHEMICALS

12. In order to check the test procedure, a reference chemical of known biodegradability should be tested in parallel. For this purpose, aniline, sodium benzoate or ethylene glycol may be used when testing water-soluble test chemicals and 1-octanol for poorly soluble test chemicals (13). Biodegradation of these chemicals must reach > 60 % ThIC within 14 days.

## REPRODUCIBILITY

13. In the ISO ring test of the method (17), the following results were obtained using the recommended conditions, including 20 mg C test chemical/l.

Test Chemical	Mean Percentage Biodegradation (28d)	Coefficient of variation (%)	Number of Laboratories
Aniline	90	16	17
1-Octanol	85	12	14

Within-test variability (replicability), using aniline, was low with coefficients of variability not greater than 5 % in nearly all test runs. In the two cases in which the replicability was worse, the greater variability was probably due to high IC production in the blanks. Replicability was worse with 1-octanol but was still less than 10 % for 79 % of test runs. This greater within-test variability may have been due to dosing errors, as a small volume (3 to 4 µl) of 1-octanol had to be injected into sealed test bottles. Higher coefficients of variation would result when lower concentrations of test chemical are used, especially at concentrations lower than 10 mg C/l. This could be partially overcome by reducing the concentration of total inorganic carbon (TIC) in the inoculum.

14. In an EU ring-test (24) of five surfactants added at 10 mg C/l, the following results were obtained:

Test Chemical	Mean Percentage biodegradation (28d)	Coefficient of variation (%)	Number of laboratories
Tetrapropylene Benzene sulphonate	17	45	10
Di-iso-octylsulpho-Succinate (anionic)	72	22	9
Hexadecyl-trimethyl (*) Ammonium chloride (cationic)	75	13	10

Test Chemical	Mean Percentage biodegradation (28d)	Coefficient of variation (%)	Number of laboratories
Iso-Nonylphenol - (ethoxylate) <sub>9</sub> (non-ionic)	41	32	10
Coco-amide-propyl Dimethylhydroxy Sulphobetaine (amphoteric)	60	23	11

(\*) SiO<sub>2</sub> was added to neutralize toxicity.

The results show that generally, the variability was higher for the less well-degraded surfactants. Within-test variability was less than 15 % for over 90 % of cases, the highest reaching 30-40 %.

NOTE: Most surfactants are not single molecular species but are mixtures of isomers, homologues, etc. which degrade after different characteristic lag periods and at different kinetic rates resulting in "blurred", extenuated curves, so that the 60 % pass value may not be reached within "the 10-d window", even though each individual molecular species would reach > 60 % within 10 days if tested alone. This may be observed with other complex mixtures as well.

#### DESCRIPTION OF THE METHOD

##### *Apparatus*

15. Normal laboratory apparatus and:

- (a) Glass serum bottles, sealed with butyl rubber stoppers and crimp-on aluminium seals. The recommended size is "125 ml" which have a total volume of around 160 ml (in this case the volume of each bottle should be known to be  $160 \pm 1$  ml). A smaller size of vessel may be used when the results fulfil the conditions described in paragraph 66 and 67;
- (b) Carbon analyser or other instrument (e.g. gas chromatograph) for measuring inorganic carbon;
- (c) Syringes of high precision for gaseous and liquid samples;
- (d) Orbital shaker in a temperature-controlled environment;
- (e) A supply of CO<sub>2</sub> free air — this can be prepared by passing air through soda lime granules or by using an 80 % N<sub>2</sub>/20 % O<sub>2</sub> gas mixture (optional) (see paragraph 28);
- (f) Membrane-filtration device of 0,20–0,45 µm porosity (optional);
- (g) Organic carbon analyser (optional).

##### *Reagents*

16. Use analytical grade reagents throughout.

##### *Water*

17. Distilled or de-ionised water should be used containing  $\leq 1$  mg/l as total organic carbon. This represents  $\leq 5$  % of the initial organic carbon content introduced by the recommended dose of the test chemical.

##### *Stock solutions for the mineral salts medium*

18. The stock solutions and the mineral salts medium are similar to those in ISO 14593 (16) and C.4 "ready biodegradability" tests (20). The use of a higher concentration of ammonium chloride (2,0 g/l instead of 0,5 g/l) should only be necessary in very exceptional cases, e.g. when the test chemical concentration is > 40 mg C/l. Stock solutions should be stored under refrigeration and disposed of after six months, or earlier if there is evidence of precipitation or microbial growth. Prepare the following stock solutions:

(a) Potassium dihydrogen phosphate ( $\text{KH}_2\text{PO}_4$ ) 8,50 g

Dipotassium hydrogen phosphate ( $\text{K}_2\text{HPO}_4$ ) 21,75 g

Disodium hydrogen phosphate dihydrate ( $\text{Na}_2\text{HPO}_4 \cdot 2\text{H}_2\text{O}$ ) 33,40 g

Ammonium chloride ( $\text{NH}_4\text{Cl}$ ) 0,50 g

Dissolve in water and make up to 1 litre. The pH of this solution should be 7,4 ( $\pm 0,2$ ). If this is not the case, then prepare a new solution.

(b) Calcium chloride dihydrate ( $\text{CaCl}_2 \cdot 2\text{H}_2\text{O}$ ) 36,40 g

Dissolve in water and make up to 1 litre.

(c) Magnesium sulphate heptahydrate ( $\text{MgSO}_4 \cdot 7\text{H}_2\text{O}$ ) 22,50 g

Dissolve in water and make up to 1 litre.

(d) Iron (III) chloride hexahydrate ( $\text{FeCl}_3 \cdot 6\text{H}_2\text{O}$ ) 0,25 g

Dissolve in water and make up to 1 litre and add one drop of concentrated HCl.

#### *Preparation of mineral medium*

19. Mix 10 ml of solution (a) with approximately 800 ml water (paragraph 17), then add 1 ml of solutions (b), (c) and (d) and make up to 1 litre with water (paragraph 17).

#### *Other reagents*

20. Concentrated ortho-phosphoric acid ( $\text{H}_3\text{PO}_4$ ) (> 85 % mass per volume).

#### *Sodium hydroxide solution 7M*

21. Dissolve 280 g of sodium hydroxide (NaOH) in 1 litre of water (paragraph 17). Determine the concentration of DIC of this solution and consider this value when calculating the test result (see paragraphs 55 and 61), especially in the light of the validity criterion in paragraph 66 (b). Prepare a fresh solution if the concentration of DIC is too high.

#### *Test chemical*

22. Prepare a stock solution of a sufficiently water-soluble test chemical in water (paragraph 17) or in the test medium (paragraph 19) at a concentration preferably 100-fold greater than the final concentration to be used in the test; it may be necessary to adjust the pH of the stock solution. The stock solution should be added to the mineral medium to give a final organic carbon concentration of between 2 and 40 mg C/l, preferably 20 mg C/l. If concentrations lower than these are used, the precision obtained may be impaired. Soluble and insoluble liquid chemicals may be added to the vessels directly using high precision syringes. Poorly soluble and insoluble test chemicals may require special treatment (25). The choices are:

(a) direct addition of known weighed amounts;

(b) ultrasonic dispersion before addition;

(c) dispersion with the aid of emulsifying agents to be required to establish whether they have any inhibitory or stimulatory effects on microbial activity before addition;

(d) adsorption of liquid test chemicals, or a solution in a suitable volatile solvent, on to an inert medium or support (e.g. glass fibre filter), followed by evaporation of the solvent, if used, and direct addition of known amounts;

(e) addition of known volume of a solution of the test chemical in an easily volatile solvent to an empty test vessel, followed by evaporation of the solvent.

Agents or solvents used in (c), (d) and (e) have to be tested for any stimulatory or inhibitory effect on microbial activity (see paragraph 42(b).)

*Reference chemical*

23. Prepare a stock solution of the (soluble) reference chemical in water (paragraph 17) at a concentration preferably 100-fold greater than the final concentration to be used (20 mg C/l) in the test.

*Inhibition check*

24. Test chemicals frequently show no significant degradation under the conditions used in ready biodegradation assessments. One possible cause is that the test chemical is inhibitory to the inoculum at the concentration at which it is applied in the test. An inhibition check may be included in the test design to facilitate identification (in retrospect) of inhibition as a possible cause or contributory factor. Alternatively, the inhibition check may rule out such interferences and show that zero or slight degradation is attributable solely to non-amenability to microbial attack under the conditions of the test. In order to obtain information on the toxicity of the test chemical to (aerobic) micro-organisms, prepare a solution in the test medium containing the test chemical and the reference chemical (paragraph 19), each at the same concentrations as added, respectively (see paragraph 22 and 23).

*Inoculum*

25. The inoculum may be derived from a variety of sources: activated sludge; sewage effluent (non-chlorinated); surface waters and soils; or from a mixture of these (20). The biodegradative activity of the source should be checked by using a reference chemical. Whatever the source, micro-organisms previously exposed to the test chemical should not be used if the procedure is to be used as a test for ready biodegradability.

Warning: Activated sludge, sewage and sewage effluent contain pathogenic organisms and must be handled with caution.

26. Based on experience, the optimal volume for the inoculum is that which:
- is sufficient to give adequate biodegradative activity;
  - degrades the reference chemical by the stipulated percentage (see paragraph 66);
  - gives  $10^2$  to  $10^5$  colony-forming units per millilitre in the final mixture;
  - normally gives a concentration of 4 mg/l suspended solids in the final mixture when activated sludge is used, concentrations up to 30 mg/l may be used but may significantly increase CO<sub>2</sub> production of the blanks (26);
  - contributes less than 10 % of the initial concentration of organic carbon introduced by the test chemical;
  - is generally 1-10 ml of inoculum for 1 litre of test solution.

*Activated sludge*

27. Activated sludge is freshly collected from the aeration tank of a sewage treatment plant or laboratory-scale unit treating predominantly domestic sewage. If necessary, coarse particles should be removed by sieving (e.g. using a 1 mm<sup>2</sup> mesh sieve) and the sludge should be kept aerobic until used.
28. Alternatively, after removal of any coarse particles, settle or centrifuge (e.g. 1 100 × g for 10 minutes). Discard the supernatant liquid. The sludge may be washed in the mineral solution. Suspend the concentrated sludge in mineral medium to yield a concentration of 3-5 g suspended solids/l. Thereafter aerate until required.
29. Sludge should be taken from a properly working conventional treatment plant. If sludge has to be taken from a high rate treatment plant, or is thought to contain inhibitors, it should be washed. Settle or centrifuge the re-suspended sludge after thorough mixing, discard the supernatant liquid and again suspend the washed sludge in a further volume of mineral medium. Repeat this procedure until the sludge is considered to be free from excess substrate or inhibitor.
30. After complete re-suspension is achieved, or with untreated sludge, withdraw a sample just before use for the determination of the dry weight of the suspended solids.

31. A further alternative is to homogenise activated sludge (3-5 g suspended solids/l). Treat the sludge in a Waring blender for 2 minutes at medium speed. Settle the blended sludge for 30 minutes or longer if required and decant liquid for use as inoculum at the rate of about 10 mg/l of mineral medium.
32. Still further reduction of the blank CO<sub>2</sub> evolution can be achieved by aerating the sludge overnight with CO<sub>2</sub>-free air. Use 4 mg/l activated sludge solids as the concentration of the inoculum in this test (13).

#### *Secondary sewage effluent*

33. Alternatively, the inoculum can be derived from the secondary effluent of a treatment plant or laboratory-scale unit receiving predominantly domestic sewage. Maintain the sample under aerobic conditions and use on the day of collection, or pre-condition if necessary. The effluent should be filtered through a coarse filter to remove gross particulate matter and the pH value is measured.
34. To reduce its IC content, the filtrate is sparged with CO<sub>2</sub>-free air (paragraph 15-e) for 1 h while maintaining the pH at 6,5 using orthophosphoric acid (paragraph 20). The pH value is restored to its original value with sodium hydroxide (paragraph 21) and after settling for about 1 h a suitable volume of the supernatant is taken for inoculation. This sparging procedure reduces the IC content of the inoculum. For example, when the maximum recommended volume of filtered sparged effluent (100 ml) per litre was used as inoculum, the amount of IC present in blank control vessels was in the range 0,4 to 1,3 mg/l (14), representing 2-6,5 % of test chemical C at 20 mg C/l and 4-13 % at 10 mg C/l.

#### *Surface waters*

35. A sample is taken of an appropriate surface water. It should be kept under aerobic conditions and used on the day of collection. The sample should be concentrated, if necessary, by filtration or centrifugation. The volume of inoculum to be used in each test vessel should meet the criteria given in paragraph 26.

#### *Soils*

36. A sample is taken of an appropriate soil, collected to a depth of up to 20 cm below the soil surface. Stones, plant remains and invertebrates should be removed from the sample of soil before it is sieved through a 2 mm mesh (if the sample is too wet to sieve immediately, then partially air dry to facilitate sieving). It should be kept under aerobic conditions and used on the day of collection (if the sample is transported in a loosely-tied black polythene bag, it can be stored at 2 to 4 °C in the bag for up to one month).

#### *Preconditioning of inoculum*

37. Inoculum may be pre-conditioned to the experimental conditions, but not pre-adapted to the test chemical. Pre-conditioning can reduce the blank CO<sub>2</sub> evolution. Pre-conditioning consists of aerating activated sludge after diluting in test medium to 30 mg/l with moist CO<sub>2</sub>-free air for up to 5-7 days at the test temperature.

#### **TEST PROCEDURE**

##### *Number of bottles*

38. The number of bottles (paragraph 15-a) needed for a test will depend on the frequency of analysis and the test duration.
39. It is recommended that triplicate bottles be analysed after a sufficient number of time intervals such that the 10-d window may be identified. Also at least five test bottles (paragraph 15-a) from sets (a), (b) and (c) (see paragraph 42) are analysed at the end of the test, to enable 95 % confidence intervals to be calculated for the mean percentage biodegradation value.

##### *Inoculated medium*

40. The inoculum is used at a concentration of 4 mg/l activated sludge dry solids. Prepare immediately before use sufficient inoculated medium by adding, for example, 2 ml suitably treated activated sludge (paragraphs 27 to 32) at 2 000 mg/l to 1 litre of mineral salts medium (paragraph 19). When secondary sewage effluent is to be used add up to 100 ml effluent (paragraph 33) to 900 ml mineral salts medium (paragraph 19) and dilute to 1 litre with medium.

*Preparation of bottles*

41. Aliquots of inoculated medium are dispensed into replicate bottles to give a headspace to liquid ratio of 1:2 (e.g. add 107 ml to 160 ml-capacity bottles). Other ratios may be used, but see the warning given in paragraph 11. When using either type of inoculum, care must be taken to ensure that the inoculated medium is adequately mixed to ensure that it is uniformly distributed to the test bottles.
42. Sets of bottles (paragraph 15a) are prepared to contain the following:
  - (a) Test vessels (denoted  $F_T$ ) containing the test chemical;
  - (b) Blank controls (denoted  $F_B$ ) containing only the test medium plus inoculum; any chemicals, solvents, agents or glass fibre filters used to introduce the test chemical into the test vessels must also be added;
  - (c) Vessels (denoted  $F_C$ ) for checking the procedure containing the reference chemical;
  - (d) If needed, vessels (denoted  $F_I$ ) for checking a possible inhibitory effect of the test chemical containing both the test chemical and reference chemical at the same concentrations (paragraph 24) as in bottles  $F_T$  and  $F_C$ , respectively;
  - (e) Vessels (denoted  $F_S$ ) for checking a possible abiotic degradation as (a) plus 50 mg/l  $HgCl_2$  or sterilised by some other means (e.g. by autoclaving).
43. Water-soluble test chemicals and reference chemicals are added as aqueous stock solutions (paragraphs 22, 23 and 24) to give a concentration of 10 to 20 mg C/l.
44. Insoluble test chemicals and insoluble reference chemicals are added to bottles in a variety of ways (see paragraph 22a-e) according to the nature of the test chemical, either before or after addition of the inoculated medium, depending on the method of treatment of the test chemical. If one of the procedures given in paragraph 22a-e is used, then the blank bottles  $F_B$  (paragraph 42b) should be treated in a similar fashion but excluding the test chemical or reference chemical.
45. Volatile test chemicals should be injected into sealed bottles (paragraph 47) using a micro syringe. The dose is calculated from the volume injected and the density of the test chemical.
46. Water should be added to vessels, where necessary, to give the same liquid volume in each vessel. It must be ensured that the headspace to liquid ratio (usually 1:2) and concentration of the test chemical are such that sufficient oxygen is available in the headspace to allow for complete biodegradation.
47. All bottles are then sealed for example, with butyl rubber septa and aluminium caps. Volatile test chemicals should be added at this stage (paragraph 45). If the decrease in DOC concentration of the test solution is to be monitored and for time zero analyses to be performed for initial IC concentration (sterile controls, paragraph 42e) or other determinands, remove an appropriate sample from the test vessel. The test vessel and its contents are then discarded.
48. The sealed bottles are placed on a rotary shaker (paragraph 15d), with a shaking rate sufficient to keep the bottle contents well mixed and in suspension (e.g. 150 to 200 rpm), and incubated in the dark at 20 °C, to be kept within  $\pm 1$  °C.

*Sampling*

49. The pattern of sampling will depend on the lag period and kinetic rate of biodegradation of the test chemical. Bottles are sacrificed for analysis on the day of sampling, which should be at least weekly or more frequently (e.g. twice per week) if a complete degradation curve is required. The requisite number of replicate bottles is taken from the shaker, representing  $F_T$ ,  $F_B$  and  $F_C$  and, if used  $F_I$  and  $F_S$  (see paragraph 42). The test normally runs for 28d. If the biodegradation curve indicates that a plateau has been attained before 28d, the test may be concluded earlier than 28d. Take samples from the five bottles reserved for the 28th day of the test for analysis and use the results to calculate the confidence limits or coefficient of variation of percentage biodegradation. Bottles representing the checks for inhibition and for abiotic degradation need not be sampled as frequently as the other bottles; day 1 and day 28 would be sufficient.



*Inorganic carbon (IC) analysis*

50. CO<sub>2</sub> production in the bottles is determined by measuring the increase in the concentration of inorganic carbon (IC) during incubation. There are two recommended methods available for measuring the amount of IC produced in the test, and these are described immediately below. Since the methods can give slightly different results only one should be used in a test run.
51. Method (a) is recommended if the medium is likely to contain remnants of, for example, a glass-filter paper and/or insoluble test chemical. This analysis can be performed using a gas chromatograph if a carbon analyser is not available. It is important that the bottles should be at or close to the test temperature when the headspace gas is analysed. Method (b) can be easier for laboratories using carbon analysers to measure IC. It is important that the sodium hydroxide solution (paragraph 21) used to convert CO<sub>2</sub> to carbonate is either freshly prepared or its IC content is known, so that this can be taken into account when calculating the test results (see paragraph 66-b.)

*Method (a): acidification to pH < 3*

52. Before each batch of analyses, the IC analyser is calibrated using an appropriate IC standard (e.g. 1 % w/w CO<sub>2</sub> in N<sub>2</sub>). Concentrated orthophosphoric acid (paragraph 20) is injected through the septum of each bottle sampled to lower the pH of the medium to < 3 (e.g. add 1 ml to 107 ml test medium). The bottles are placed back on the shaker. After shaking for one hour at the test temperature the bottles are removed from the shaker, aliquots (e.g. 1 ml) of gas are withdrawn from the headspace of each bottle and injected into the IC analyser. The measured IC concentrations are recorded as mg C/l.
53. The principle of this method is that after acidification to pH < 3 and equilibration at 20 °C, the equilibrium constant for the distribution of CO<sub>2</sub> between the liquid and gaseous phases in the test bottles is 1,0 when measured as a concentration (13). This should be demonstrated for the test system at least once as follows:

Set up bottles containing 5 and 10 mg/l as IC using a solution of anhydrous sodium carbonate (Na<sub>2</sub> CO<sub>3</sub>) in CO<sub>2</sub>-free water prepared by acidifying water to pH 6,5 with concentrated ortho-phosphoric acid (paragraph 20), sparging overnight with CO<sub>2</sub>-free air and raising the pH to neutrality with alkali. Ensure that the ratio of the headspace volume to the liquid volume is the same as in the tests (e.g. 1:2). Acidify and equilibrate as described in paragraph 52, and measure the IC concentrations of both the headspace and liquid phases. Check that the two concentrations are the same within experimental error. If they are not, the operator should review the procedures. This check on the distribution of IC between liquid and gaseous phases need not be made every time the test is performed; it could presumably be made while performing the calibration.

54. If DOC removal is to be measured (water-soluble test chemicals only), samples should be taken of the liquid phase from separate (non-acidified) bottles, membrane-filtered and injected into the DOC analyser. These bottles can be used for other analyses as necessary, to measure primary biodegradation.

*Method (b): conversion of CO<sub>2</sub> to carbonate*

55. Before each batch of analyses, the IC analyser is calibrated using an appropriate standard — for example, a solution of sodium bicarbonate (NaHCO<sub>3</sub>) in CO<sub>2</sub> free water (see paragraph 53) in the range 0 to 20 mg/l as IC. Sodium hydroxide solution (7M, paragraph 21) (e.g. 1 ml to 107 ml medium) is injected through the septum of each bottle sampled and the bottles are shaken for 1 h at the test temperature. Use the same NaOH solution on all bottles sacrificed on a particular day, but not necessarily on all sampling occasions throughout a test. If absolute blank IC values are required at all sampling occasions, IC determinations of the NaOH solution will be required each time it is used. The bottles are removed from the shaker and allowed to settle. Suitable volumes (e.g. 50 to 1 000 µl) of the liquid phase in each vessel are withdrawn by syringe. The samples are injected into the IC analyser and the concentrations of IC are recorded. It should be ensured that the analyser used is equipped properly to deal with the alkaline samples produced in this method.
56. The principle of this method is that after the addition of alkali and shaking, the concentration of IC in the headspace is negligible. This should be checked for the test system at least once by using IC standards, adding alkali and equilibrating, and measuring the concentration of IC in both the headspace and liquid phases (see paragraph 53). The concentration in the headspace should approach zero. This check on the virtually complete absorption of CO<sub>2</sub> need not be made every time the test is performed.
57. If DOC removal is to be measured (water-soluble test chemicals only), samples should be taken of the liquid phase from separate bottles (containing no added alkali), membrane filtered and injected into the DOC analyser. These bottles can be used for other analyses, as necessary, to measure primary biodegradability.

## DATA AND REPORTING

**Calculating of results**

58. Assuming 100 % mineralisation of the test chemical to CO<sub>2</sub>, the ThIC in excess of that produced in the blank controls equals the TOC added to each test bottle at the start of the test, that is:

$$\text{ThIC} = \text{TOC}$$

The total mass (mg) of inorganic carbon (TIC) in each bottle is:

$$\text{TIC} = (\text{mg C in the liquid} + \text{mg C in the headspace}) = (V_L \times C_L) + (V_H \times C_H) \quad \text{Equation [1]}$$

where:

V<sub>L</sub> = volume of liquid in the bottle (litre);

C<sub>L</sub> = concentration of IC in the liquid (mg/l as carbon);

V<sub>H</sub> = volume of the headspace (litre);

C<sub>H</sub> = concentration of IC in the headspace (mg/l as carbon).

The calculations of TIC for the two analytical methods used for measuring IC in this test are described below in paragraphs 60 and 61. Percentage biodegradation (% D) in each case is given by:

$$\%D = \frac{(\text{TIC}_t - \text{TIC}_b)}{\text{TOC}} \times 100 \quad \text{Equation [2]}$$

where:

TIC<sub>t</sub> = mg TIC in test bottle at time t;

TIC<sub>b</sub> = mean mg TIC in blank bottles at time t;

TOC = mg TOC added initially to the test vessel.

The percentage biodegradation % D is calculated for the test (F<sub>T</sub>), reference (F<sub>C</sub>) and, if included inhibition monitoring control (F<sub>I</sub>) bottles from the respective amounts of TIC produced up to each sampling time.

59. If there has been a significant increase in the TIC content of the sterile controls (F<sub>S</sub>) over the test period, then it may be concluded that abiotic degradation of the test chemical has occurred and this must be taken into account in the calculation of D in Equation [2].

**Acidification to pH < 3**

60. Since acidification to pH < 3 and equilibration results in the equalisation of the concentration of TIC in the liquid and gaseous phases, only the concentration of IC in the gas phase needs to be measured. Thus, from Equation [1]  $\text{TIC} = (V_L + V_H) \times C_H = V_B \times C_H$ , where V<sub>B</sub> = volume of the serum bottle.

### Conversion of CO<sub>2</sub> to carbonate

61. In this method calculations are performed as in Equation [1], but the negligible amount of IC in the gaseous phase is ignored, that is  $V_H \times C_H = 0$ , and  $TIC = V_L \times C_L$ .

### Expression of Results

62. A biodegradation curve is obtained by plotting percentage biodegradation, D, against time of incubation and if possible, the lag phase, biodegradation phase, 10-d window and plateau phase, that is the phase in which the maximal degradation has been reached and the biodegradation curve has levelled out, are indicated. If comparable results are obtained for parallel test vessels  $F_T$  (< 20 % difference), a mean curve is plotted (see Appendix 2, Fig.1); if not, curves are plotted for each vessel. The mean value of the percentage biodegradation in the plateau phase is determined or the highest value is assessed (e.g. when the curve decreases in the plateau phase), but it is important to assess that in the latter case the value is not an outlier. Indicate this maximum level of biodegradation as "degree of biodegradation of the test chemical" in the test report. If the number of test vessels was insufficient to indicate a plateau phase, the measured data of the last day of the test are used to calculate a mean value. This last value, the mean of five replicates, serves to indicate the precision with which the percentage biodegradation was determined. Also report the value obtained at the end of the 10-d window.
63. In the same way, a curve for the reference chemical,  $F_C$ , is plotted and, if included, for the abiotic elimination check,  $F_S$  and the inhibition control,  $F_I$ .
64. The amounts of TIC present in the blank controls ( $F_B$ ) are recorded as are those in flasks  $F_S$  (abiotic check), if these vessels were included in the test.
65. Calculate D for the  $F_I$  vessels, based on the theoretical IC yield anticipated from only the reference component of the mixture. If, at day 28,  $[(D_{FC}^{(1)} - D_{FI}^{(2)})/D_{FC}] \times 100 > 25 \%$ , it may be assumed that the test chemical inhibited the activity of the inoculum, and this may account for low values of  $D_{FI}$  obtained under the conditions of the test. In this case the test could be repeated using a lower test concentration and preferably reducing the DIC in the inoculum and TIC formed in the blank controls, since the lower concentration will otherwise reduce the precision of the method. Alternatively, another inoculum may be used. If in flask  $F_S$  (abiotic) a significant increase (> 10 %) in the amount of TIC is observed, abiotic degradation processes may have occurred.

### Validity of results

66. A test is considered valid if:
- (a) the mean percentage degradation in vessels  $F_C$  containing the reference chemical is > 60 % by the 14th day of incubation; and
  - (b) the mean amount of TIC present in the blank controls  $F_B$  at the end of the test is > 3 mg C/l.

If these limits are not met, the test should be repeated with an inoculum from another source and/or the procedures used should be reviewed. For example, if high blank IC production is a problem the procedure given in paragraphs 27 to 32 should be followed.

67. If the test chemical does not reach 60 % ThIC and was shown not to be inhibitory (paragraph 65), the test could be repeated with increased concentration of inoculum (up to 30 mg/l activated sludge and 100 ml effluent/l) or inocula from other sources, especially if degradation had been in the range 20 to 60 %.

### Interpretation of results

68. Biodegradation > 60 % ThIC within the 10-d window in this test demonstrates that the test chemical is readily biodegradable under aerobic conditions.
69. If the pass value of 60 % ThIC is not attained, determine the pH value in media in bottles which have not been made acid or alkaline; a value of less than 6,5 could indicate that nitrification had occurred. In such a case repeat the test with a buffer solution of higher concentration.

<sup>(1)</sup> The percentage degradation in Vessels  $F_C$  containing the reference substance.

<sup>(2)</sup> The percentage degradation in Vessels  $F_I$ .

**Test Report**

70. Compile a table of % D for each test ( $F_T$ ), reference ( $F_C$ ) and, if included, inhibition control bottle ( $F_I$ ) for each day sampled. If comparable results are obtained for replicate bottles, plot a curve of mean % D against time. Record the amount of TIC in the blanks ( $F_B$ ) and in the sterile controls ( $F_S$ ) DOC and/or other determinands, and their percentage removal.
71. Determine the mean value of % D in the plateau phase, or use the highest value if the biodegradation curve decreases in the plateau phase, and report this as the "degree of biodegradation of the test chemical". It is important to ensure that in the latter case the highest value is not an outlier.
72. The test report must include the following information:

*Test chemical:*

- common name, chemical name, CAS number, structural formula and relevant physical-chemical properties;
- purity (impurities) of test chemical.

*Test conditions:*

- reference to this Test Method;
- description of the test system used (e.g. volume of the vessel, head space to liquid ratio, method of stirring, etc.);
- application of test chemical and reference chemical to test system: test concentration used and amount of carbon dosed into each test bottle, any use of solvents;
- details of the inoculum used, any pre-treatment and pre-conditioning;
- incubation temperature;
- validation of the principle of IC analysis;
- main characteristics of the IC analyser employed (and any other analytical methods used);
- number of replicates.

*Results:*

- raw data and calculated values of biodegradability in tabular form;
- the graph of percentage degradation against time for the test and reference chemicals, the lag phase, degradation phase, 10-d window and slope;
- percentage removal at plateau, at end of test, and after 10-d window;
- reasons for any rejection of the test results;
- any other facts that are relevant to the procedure followed;
- discussion of results.

## LITERATURE:

- (1) Chapter C.4 of this Annex Determination of "Ready" Biodegradability — CO<sub>2</sub> Evolution Test (Method C.4-C).
- (2) Sturm RN (1973). Biodegradability of Nonionic surfactants: screening test for predicting rate and ultimate biodegradation. *J.A., Oil Chem Soc.* 50: 159-167.
- (3) Larson RJ (1979). Estimation of biodegradation potential of xenobiotic organic chemicals. *Appl Env. Microbiol.* 38: 1153-1161.
- (4) Larson RJ, Hansmann MA and Bookland EA (1996). Carbon dioxide recovery in ready biodegradability tests: mass transfer and kinetic constants, *Chemosphere* 33: 1195-1210.
- (5) ISO 9439 (1990; revised 1999). Water Quality — Evaluation of ultimate aerobic biodegradability of organic compounds in aqueous medium — Carbon dioxide evolution Test (Sturm).
- (6) US EPA (1996). Fate, Transport and Transformation Test Guideline. 835.3110 Carbon dioxide evolution test. Office, Prevention Pesticides and Toxic Substances Washington, DC.
- (7) US EPA (1996). Fate, Transport and Transformation Test Guideline. 835. 3100. Aerobic aquatic biodegradation. Office, Prevention Pesticides and Toxic Substances Washington, DC.
- (8) Gledhill WE (1975). Screening test for assessment of biodegradability: Linear alkyl benzene sulfonate. *Appl Microbiol.* 30: 922-929.
- (9) Weytjens D, Van Ginneken I and Painter HA (1994). The recovery of carbon dioxide in the Sturm test for ready biodegradability. *Chemosphere* 28: 801-812.
- (10) Ennis DM and Kramer A (1975). A rapid microtechnique for testing biodegradability of nylons and polyamides. *J. Food Sci.* 40: 181-185.
- (11) Ennis DM, Kramer A, Jameson CW, Mazzoccki PH and Bailey PH (1978). *Appl. Env. Microbiol.* 35: 51-53.
- (12) Boatman RJ, Cunningham SL and Ziegler DA (1986). A method for measuring the biodegradation of organic chemicals, *Env. Toxicol. Chem.* 5: 233-243.
- (13) Struijs J and Stoltenkamp J (1990). Head space determination of evolved carbon dioxide in a biodegradability screening test. *Ecotox. Env. Safety* 19: 204-211.
- (14) Birch RR and Fletcher RJ (1991). The application of dissolved inorganic carbon measurements to the study of aerobic biodegradability. *Chemosphere* 23: 507-524.
- (15) Birch RR, Biver C, Campagna R, Gledhill WE, Pagga U, Steber J, Reust H, and Bontinck WJ (1989). Screening of chemicals for anaerobic biodegradation. *Chemosphere* 19: 1527-1550.
- (16) ISO 14593, (1999) Water Quality — Evaluation of ultimate aerobic biodegradability of organic compounds in an aerobic medium-method by analysis of inorganic carbon in sealed vessels (CO<sub>2</sub> headspace test).
- (17) Battersby NS (1997). The ISO headspace CO<sub>2</sub> biodegradation test, *Chemosphere* 34: 1813-1822.
- (18) US EPA (1996). Fate, Transport and Transportation. 835.3120. Sealed vessel carbon dioxide production test. Office, Prevention Pesticides and Toxic Substance, Washington, DC.
- (19) Battersby NS, Ciccognani D, Evans MR, King D, Painter HA, Peterson DR and Starkey M (1999). An "inherent" biodegradability test for oil products: description and results of an international ring test. *Chemosphere* 38: 3219-3235.

- 
- (20) Chapter C.4 of this Annex, Determination of "Ready" Biodegradability.
- (21) OECD (1988). OECD Ring-test of methods for determining ready biodegradability: Chairman's report (M. Hashimoto; MITI) and final report (M. Kitano and M. Takatsuki; CITI). Paris.
- (22) Chapter C.11 of this Annex, Activated sludge respiration inhibition test.
- (23) Struijs J, Stoltenkamp-Wouterse MJ and Dekkers ALM (1995). A rationale for the appropriate amount of inoculum in ready biodegradability tests. *Biodegradation* 6: 319-327.
- (24) EU (1999). Ring-test of the ISO Headspace CO<sub>2</sub> method: application to surfactants: Surfactant Ring Test-1, Report EU4697, Water Research Centre, May 1999, Medmenham, SL7 2HD, UK.
- (25) ISO 10634 (1996) Water Quality — Guidance for the preparation and treatment of poorly water-soluble organic compounds for the subsequent evaluation of their biodegradability in an aqueous medium.
-

*Appendix 1*

## ABBREVIATIONS AND DEFINITIONS

**IC:** Inorganic carbon

**ThCO<sub>2</sub>:** Theoretical carbon dioxide (mg) is the quantity of carbon dioxide calculated to be produced from the known or measured carbon content of the test chemical when fully mineralised; also expressed as mg carbon dioxide evolved per mg test chemical.

**DOC:** Dissolved organic carbon is the organic carbon present in solution or that which passes through a 0,45 micrometre filter or remains in the supernatant after centrifuging at approx. 4 000 g (about 40 000 m sec<sup>-2</sup>) for 15 min.

**DIC:** Dissolved inorganic carbon

**ThIC:** Theoretical inorganic carbon

**TIC:** Total inorganic carbon

**Readily biodegradable:** An arbitrary classification of chemicals which have passed certain specified screening tests for ultimate biodegradability; these tests are so stringent that it is assumed that such chemicals will rapidly and completely biodegrade in aquatic environments under aerobic conditions.

**10-d window:** The 10 days immediately following the attainment of 10 % biodegradation.

**Inherent biodegradability:** A classification of chemicals for which there is unequivocal evidence of biodegradation (primary or ultimate) in any test of biodegradability.

**Ultimate aerobic biodegradation:** The level of degradation achieved when the test chemical is totally utilised by microorganisms resulting in the production of carbon dioxide, water, mineral salts and new microbial cellular constituents (biomass).

**Mineralisation:** Mineralisation is the complete degradation of an organic chemical to CO<sub>2</sub> and H<sub>2</sub>O under aerobic conditions, and CH<sub>4</sub>, CO<sub>2</sub> and H<sub>2</sub>O under anaerobic conditions.

**Lag phase:** The time from the start of a test until acclimatization and/or adaptation of the degrading microorganisms is achieved and the biodegradation degree of a test chemical or organic matter has increased to a detectable level (e.g. 10 % of the maximum theoretical biodegradation, or lower, dependent on the accuracy of the measuring technique).

**Degradation phase:** The time from the end of the lag period to the time when 90 % of the maximum level of degradation has been reached.

**Plateau phase:** Plateau phase is the phase in which the maximal degradation has been reached and the biodegradation curve has levelled out.

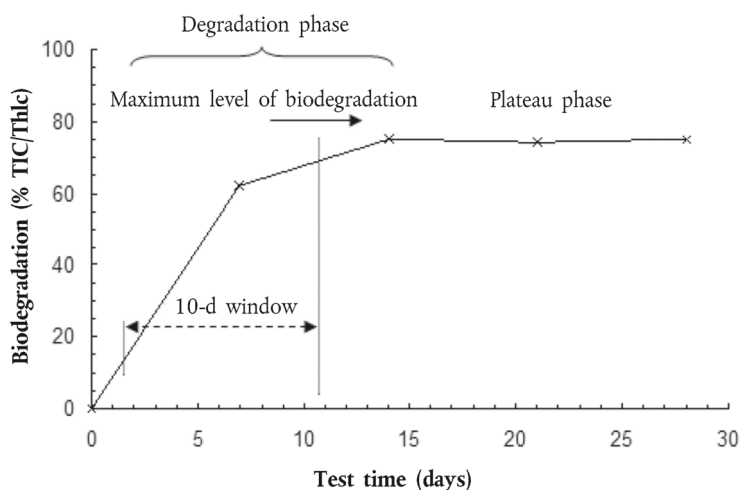
**Test chemical:** Any substance or mixture tested using this Test Method.

---

## Appendix 2

## Example of a biodegradation curve

Figure 1

Biodegradation of 1-octanol in the CO<sub>2</sub> headspace test

## Glossary

Biodegradation:

Degradation phase:

Maximum level of biodegradation:

Plateau phase:

10-d(ay) window:

Test time (days):

## C. 30. BIOACCUMULATION IN TERRESTRIAL OLIGOCHAETES

## INTRODUCTION

1. This Test Method is equivalent to OECD Test Guideline (TG) 317 (2010). Among the Test Methods relating to environmental fate, the Bioconcentration: Flow-through Fish Test (chapter C.13 of this Annex (49)) and the Bioaccumulation in Sediment-dwelling Benthic Oligochaetes (53) were published in 1996 and 2008 respectively. The extrapolation of aquatic bioaccumulation data to terrestrial organisms like earthworms is difficult, if possible at all. Model calculations based on a test chemical's lipophilicity, e.g. (14) (37), are currently used for the assessment of bioaccumulation of chemicals in soil, as e.g. in the EU Technical Guidance Document (19). The need for a compartment-specific test method has already been addressed, e.g. (55). Such a method is especially important for the evaluation of secondary poisoning in terrestrial food chains (4). Several national test methods address the issue of bioaccumulation in organisms other than fish e.g. (2) and (72). A method on the measurement of bioaccumulation from contaminated soils in earthworms (*Eisenia fetida*, Savigny) and potworms has been developed by the American Society for Testing and Materials (3). An internationally accepted method for the determination of bioaccumulation in spiked soil will improve the risk assessment of chemicals in terrestrial ecosystems e.g. (25) (29).
2. Soil-ingesting invertebrates are exposed to soil bound chemicals. Among these animals, terrestrial oligochaetes play an important role in the structure and function of soils (15) (20). Terrestrial oligochaetes live in soil and partly at the soil surface (especially the litter layer); they frequently represent the most abundant species in terms of biomass (54). By bioturbation of the soil and by serving as prey these animals can have a strong influence on the bioavailability of chemicals to other organisms like invertebrates (e.g. predatory mites and beetles; e.g. (64)) or vertebrate (e.g. foxes and gulls) predators (18) (62). Some species of terrestrial oligochaetes currently used in ecotoxicological testing are described in Appendix 5.



3. The ASTM Standard Guide for Conducting Laboratory Soil Toxicity or Bioaccumulation Tests with the Lumbricid Earthworm *Eisenia fetida* and the Enchytraeid Potworm *Enchytraeus albidus* (3) provides many essential and useful details for the performance of the present soil bioaccumulation Test Method. Further documents that are referred to in this Test Method are chapter C.13 of this Annex, Bioconcentration: Flow-through Fish Test (49) and OECD TG 315: Bioaccumulation in Sediment-dwelling Benthic Oligochaetes (53). Practical experience with soil bioaccumulation studies and publications from LITERATURE e.g. (1) (5) (11) (12) (28) (40) (43) (45) (57) (59) (76) (78) (79) are also major sources of information for this Test Method.
4. This Test Method is mostly applicable to stable, neutral organic chemicals, which tend to adsorb to soils. Testing for bioaccumulation of soil-associating, stable metallo-organic compounds may be possible with this Test Method. It is also applicable to metals and other trace elements.

#### PRE-REQUISITE

5. Tests for measuring the bioaccumulation of a chemical in terrestrial oligochaetes have been performed with heavy metals (see e.g. (63)) and persistent, organic chemicals having log K<sub>ow</sub> values between 3,0 and 6,0, e.g. (40). Such tests also apply to:
  - Chemicals that show a log K<sub>ow</sub> of more than 6,0 (super-hydrophobic chemicals);
  - Chemicals which belong to a class of organic chemicals known to have the potential to bioaccumulate in living organisms, e.g. surface active or highly adsorptive chemicals;
  - Chemicals that indicate the potential for bioaccumulation from structural features, e.g. analogues of chemicals with known bioaccumulation potential; and
  - Metals.
6. Information on the test chemical such as common name, chemical name (preferably IUPAC name), structural formula, CAS registry number, purity, safety precautions, proper storage conditions and analytical methods should be obtained before beginning the study. In addition, the following information should be known:
  - (a) solubility in water;
  - (b) octanol-water partition coefficient, K<sub>ow</sub>;
  - (c) soil-water partition coefficient, expressed as K<sub>oc</sub>;
  - (d) vapour pressure;
  - (e) degradability (e.g. in soil, water);
  - (f) known metabolites.
7. Radiolabelled or non-radiolabelled test chemicals can be used. However, to facilitate analysis it is recommended to use a radiolabelled test chemical. The decision will be made based on the detection limits or a requirement to measure parent test chemical and metabolites. If a radiolabelled test chemical is used and total radioactive residues are measured, it is important that the radiolabelled residues in both the soil and the test organisms are characterised for percentages of parent test chemical and labelled non-parent, e.g. in samples taken at steady state or at the end of the uptake phase, to allow a bioaccumulation factor (BAF) calculation for the parent test chemical and for the soil metabolites of concern (see paragraph 50). The method described here may have to be modified, e.g. to provide sufficient biomass, for measuring non-radiolabelled organic test chemical or metals. When total radioactive residues are measured (by liquid scintillation counting following extraction, combustion or tissue solubilisation), the bioaccumulation factor is based on the parent test chemical and metabolites. The BAF calculation should preferably be based on the concentration of the parent test chemical in the organisms and total radioactive residues. Subsequently, the biota-soil accumulation factor (BSAF), normalized to the lipid content of worm and organic carbon content (OC) of soil should be calculated from the BAF for reasons of comparability between results from different bioaccumulation tests.

8. Toxicity of the test chemical to the species used in the test should be known, e.g. an effect concentration (EC<sub>x</sub>) or lethal concentration (LC<sub>x</sub>) for the time of the uptake phase (e.g. (19)). The selected concentration of the test chemical should preferably be about 1 % of its acute asymptotic LC<sub>50</sub>, and at least 10-fold higher than its detection limit in soil by the analytical method used. If available, preference should be given to toxicity values derived from long-term studies on sublethal endpoints (51) (52). If such data are not available, an acute toxicity test will provide useful information (see e.g. (23)).
9. An appropriate analytical method of known accuracy, precision, and sensitivity for the quantification of the chemical in the test solutions, in the soil, and in the biological material should be available, together with details of sample preparation and storage as well as material safety data sheets. Analytical detection limits of the test item in soil and worm tissue should also be known. If a <sup>14</sup>C-labelled test chemical is used, the specific radioactivity (i.e. Bq mol<sup>-1</sup>) and the percentage of radioactivity associated with impurities should be known. The specific radioactivity of the test chemical should be high enough to facilitate analysis, and the test concentrations used should not elicit toxic effects.
10. The test can be performed with an artificial soil or with natural soils. Information on characteristics of the natural soil used, e.g. origin of soil or its constituents, pH, organic carbon content, particle size distribution (percent sand, silt, and clay), and water holding capacity (WHC), should be known before the start of the test (3) (48).

#### PRINCIPLE OF THE TEST

11. The parameters which characterise the bioaccumulation of a test chemical include the bioaccumulation factor (BAF), the uptake rate constant ( $k_s$ ) and the elimination rate constant ( $k_e$ ). Definitions are provided in Appendix 1.
12. The test consists of two phases: the uptake (exposure) phase and the elimination (post-exposure) phase. During the uptake phase, replicated groups of worms are exposed to soil, which has been spiked with the test chemical. In addition to the test animals, groups of control worms are held under identical conditions without the test chemical. The dry weight and lipid content of the test organisms are measured. This can be done using worms of the control group. Analytical background values (blank) can be obtained by analysing samples of the control worms and soil. For the elimination phase, the worms are transferred to a soil free of the test chemical. An elimination phase is always required unless uptake of the test chemical during the exposure phase has been insignificant. An elimination phase provides information on the rate at which the test chemical is excreted by the test organisms (e.g. (27)). If a steady state has not been reached during the uptake phase, the determination of the kinetic parameters – kinetic bioaccumulation factor BAF<sub>k</sub>, uptake and elimination rate constant(s) – should preferably be based on simultaneous fitting of the results of the uptake and elimination phases. The concentration of the test chemical in/on the worms is monitored throughout both phases of the test.
13. During the uptake phase, measurements are made at sampling times up to 14 days (enchytraeids) or 21 days (earthworms) until the steady state is reached (11) (12) (67). The steady state occurs when a plot of the concentration in worms against time is parallel to the time axis, and three successive concentration analyses made on samples taken at intervals of at least two days do not vary more than ± 20 % of each other based on statistical comparisons (e.g. analysis of variance, regression analysis).
14. The elimination phase consists of transferring the test organisms to vessels containing the same substrate without the test chemical. During the elimination phase, measurements are made at sampling times during 14 days (enchytraeids) or 21 days (earthworms) unless earlier analytical determination showed 90 % reduction of the test chemical residues in worms. The concentration of the test chemical in the worms at the end of the elimination phase is reported as non-eliminated residues. The steady state bioaccumulation factor (BAF<sub>ss</sub>) is calculated preferably both as the ratio of the concentration in worms (C<sub>a</sub>) and in the soil (C<sub>s</sub>) at apparent steady state, and as a kinetic bioaccumulation factor, BAF<sub>k</sub>, as the ratio of the rate constant of uptake from soil ( $k_s$ ) and the elimination rate constant ( $k_e$ ) (see Appendix 1 for definitions) assuming first-order kinetics (see Appendix 2 for calculations). If first-order kinetics is obviously not applicable, other models should be employed.
15. The uptake rate constant, the elimination rate constant (or constants, where other models are involved), the kinetic bioaccumulation factor (BAF<sub>k</sub>), and where possible, the confidence limits of each of these parameters are calculated from computerised model equations (see Appendix 2 for guidance). The goodness of fit of any model can be determined from e.g. the correlation coefficient or the coefficient of determination (coefficients close to one indicate a good fit) or chi-squared. Also the size of the standard error or confidence limit around the estimated parameters may be indicative of the goodness of fit of the model.
16. To reduce variability in test results for test chemicals with high lipophilicity, bioaccumulation factors should be expressed in relation to lipid content and organic carbon content (kg soil organic carbon (OC) kg<sup>-1</sup> worm lipid content). This approach is based on the fact that for some chemical classes, there is a clear relationship between

the potential for bioaccumulation and lipophilicity; this has been well established for fish (47). There is a relationship between the lipid content of fish and the bioaccumulation of such chemicals. For benthic organisms, similar correlations have been found e.g. (30) (44). Likewise for terrestrial oligochaetes this correlation has been demonstrated e.g. (5) (6) (7) (14). If sufficient worm tissue is available, the lipid content of the test animals can be determined on the same biological material as the one used to determine the concentration of the test chemical. Alternatively, control animals can be used to measure the lipid content.

#### VALIDITY OF THE TEST

17. For a test to be valid the following criteria should be fulfilled for both controls and treatments:

- At the end of the test, the overall mortality during uptake and elimination phase should not exceed 10 % (earthworms) or 20 % (enchytraeids) of the total number of the introduced worms.
- For *Eisenia fetida* and *Eisenia andrei*, the mean mass loss as measured at the end of the uptake and at the end of the elimination phase should not exceed 20 % compared to the initial fresh weight (f.w.) at start of each phase.

#### DESCRIPTION OF THE METHOD

##### Test species

18. Several species of terrestrial oligochaetes are recommended for bioaccumulation testing. The most commonly used species *Eisenia fetida* or *Eisenia andrei* (Lumbricidae), or *Enchytraeus albidus*, *Enchytraeus crypticus*, or *Enchytraeus luxuriosus* (Enchytraeidae) are described in Appendix 5.

##### Apparatus

19. Care should be taken to avoid the use of materials, for all parts of the equipment, which can dissolve, adsorb the test chemical or leach other chemicals, and have an adverse effect on the test animals. Standard rectangular or cylindrical vessels, made of chemically inert material and of suitable capacity can be used in compliance with the loading rate, i.e. the number of test worms. Stainless steel, plastic or glass may be used for any equipment having contact with the test media. The test vessels should be appropriately covered to prevent escaping of the worms, while allowing sufficient air supply. For chemicals with high adsorption coefficients, such as synthetic pyrethroids, silanised glass may be required. In these situations the equipment will have to be discarded after use (49). Radiolabelled test items and volatile chemicals should be prevented from escaping. Traps (e.g. glass gas washing bottles) should be employed containing suitable absorbents to retain any residues evaporating from the test vessels.

##### Soil

20. The test soil should be of a quality that will allow the survival and preferably the reproduction of the test organisms for the duration of the acclimation and test periods without them showing any abnormal appearance or behaviour. The worms should burrow in the soil.
21. The artificial soil described in the chapter C.8 of this Annex (48) is recommended for use as the substrate in the tests. Preparation of the artificial soil for use in the bioaccumulation tests and recommendations for the storage of artificial soil are given in Appendix 4. Air-dried artificial soil may be stored at room temperature until use.
22. However, natural soils from unpolluted sites may serve as test and/or culture soil. Natural soils should be characterised at least by origin (collection site), pH, organic carbon content, particle size distribution (percent sand, silt, and clay), maximum water holding capacity (WHC<sub>max</sub>), and percent water content (3). Analysis of the soil or its constituents for micro-pollutants prior to use should provide useful information. If field soil from agricultural land is used, it should not have been treated with crop protection products or with manure from treated animals as fertilizers for at least one year and with organic fertilizers for at least six months prior to sampling (50). Manipulation procedures for natural soils prior to use in ecotoxicological tests with oligochaetes in the laboratory are described in (3). For natural soils the storage time in the laboratory should be kept as short as possible.

##### Application of the test chemical

23. The test chemical is incorporated into the soil. The physicochemical properties of the test chemical should be taken into consideration. A water-soluble test chemical should be completely dissolved in water before it be mixed with the soil. The recommended spiking procedure for poorly water-soluble test chemical involves coating of one or more of the (artificial) soil constituents with the test chemical. For example, the quartz

sand, or a portion thereof, can be soaked with a solution of the test chemical in a suitable organic solvent, which is then slowly evaporated to dryness. The coated fraction can then be mixed into the wet soil. The major advantage of this procedure is that no solvent is introduced into the soil. When a natural soil is used, the test chemical may be added by spiking an air-dried portion of the soil as described above for the artificial soil, or by stirring the test chemical into the wet soil, with subsequent evaporating step if a solubilising agent is used. In general, the contact of wet soil with solvents should be avoided as far as possible. The following should be considered (3):

- If a solvent other than water is used, it should be one that is water-miscible and/or can be driven off (for example, evaporated), leaving only the test chemical on the soil.
  - If a solvent control is used, there is no need for negative control. The solvent control should contain the highest concentration of solvent added to the soil and should use solvent from the same batch used to make the stock solution. Toxicity and volatility of the solvent, and solubility of the test chemical in the chosen solvent should be the main criteria used for the selection of a suitable solubilising agent.
24. For chemicals that are poorly soluble in water and in organic solvents, 2,0-2,5 g of finely ground quartz sand per test vessel can be mixed with the quantity of test chemical, e.g. using mortar and pestle, to obtain the desired test concentration. This mixture of quartz sand and test chemical is added to the pre-moistened soil and thoroughly mixed with an appropriate amount of de-ionised water to obtain the required moisture content. The final mixture is distributed to the test vessels. The procedure is repeated for each test concentration, and an appropriate control with 2,0-2,5 g of finely ground quartz sand per test vessel is also prepared.
25. The concentration of the test chemical in the soil should be determined after spiking. The homogenous distribution of the test chemical into the soil should be verified before introducing the test organisms. The method used for spiking, and the reasons for choosing a specific spiking procedure should be reported (24).
26. Equilibrium between the soil and the pore-water phase should ideally be established before adding the organisms; a time period of four days at 20 °C is recommended. For many poorly water-soluble organic chemicals the time required to reach a true equilibrium between adsorbed and dissolved fractions can be counted in days or months. Depending on the purpose of the study, for example when the environmental conditions are to be mimicked, the spiked soil may be "aged" for a longer period, e.g. for metals three weeks at 20 °C (22).

#### Culturing of the test organisms

27. Worms should be preferably kept in permanent laboratory culture. Guidance on laboratory culture methods for *Eisenia fetida* and *Eisenia andrei*, and Enchytraeid species, is provided in Appendix 5 (see also (48) (51) (52)).
28. The worms used in the tests should be free from observable diseases, abnormalities and parasites.

#### PERFORMANCE OF THE TEST

29. The test organisms are exposed to the test chemical during the uptake phase. The uptake phase should be of 14 days (enchytraeids) or 21 days (earthworms) unless it is demonstrated that steady state has been reached.
30. For the elimination phase, the worms are transferred to a soil free of test chemical. The first sample should be taken at 4-24 h after the start of elimination phase. Examples of sampling schedules for a 21-day uptake phase and a 21-day elimination phase are given in Appendix 3.

#### Test organisms

31. For many species of terrestrial enchytraeids the individual weight is very low (e.g. 5-10 mg wet weight per individual for *Enchytraeus albidus* and less for *Enchytraeus crypticus* or *Enchytraeus luxuriosus*); in order to perform the weight measurements and chemical analysis, it may be necessary to pool the worms of the replicate test vessels (i.e. all the worms of a replicate vessel will be used for obtaining one analytical tissue result). 20 individual enchytraeids are added to each replicate, and at least three replicates should be used. If the analytical detection limit of the test chemical is high, more worms may be necessary. For test species with higher individual weight (*Eisenia fetida* and *Eisenia andrei*), replicate vessels containing one individual can be used.
32. The earthworms used in a test should be of similar weight (e.g. *Eisenia fetida* and *Eisenia andrei* should have an individual weight of 250-600 mg). Enchytraeids (e.g. *Enchytraeus albidus*) should have a length of approximately 1 cm. All worms used in a particular test should come from the same source, and should be adult animals with

clitellum (see Appendix 5). Since the weight and age of an animal might have an effect on the BAF-values (e.g. due to varying lipid content and/or presence of eggs), these parameters should be recorded accurately and taken into account in the interpretation of results. In addition, cocoons can be deposited during the exposure period, which will also have an impact on the BAF values. It is recommended that a sub-sample of the test worms be weighed before the test in order to estimate the mean wet and dry weights.

33. A high soil-to-worm ratio should be used in order to minimise the decrease of the test chemical concentration in the soil during the uptake phase. For *Eisenia fetida* and *Eisenia andrei* a minimum amount of 50 g dry weight (d.w.) of soil per worm, and for enchytraeids, a minimum of 10-20 g d.w. of soil per test vessel are recommended. The vessels should contain a soil layer of 2-3 cm (enchytraeids) or 4-5 cm (earthworms).
34. The worms used in a test are removed from the culture (e.g. enchytraeids by using jeweller's tweezers). Adult animals are transferred to non-treated test soil for acclimation, and fed (see paragraph 36). If the test conditions differ from the culture conditions, an acclimation phase of 24-72 h should be sufficient to adapt the worms to the test conditions. After acclimation, earthworms are rinsed by transfer to glass dishes (e.g. petri dishes) containing clean water, and subsequently weighed before they are added to the test soil. Prior to weighing, excess water should be removed from the worms by gently touching them against the edge of the dish or by blotting them cautiously dry by using a slightly moistened paper towel.
35. Burrowing behaviour of the test organisms should be observed and recorded. In tests with earthworms, the animals (control and treatments) normally burrow in the soil within a period of a few hours; this should be checked no later than 24 h after addition of the worms to the test vessels. If the earthworms fail to burrow in the soil (e.g. more than 10 % over more than half of the uptake phase), this indicates that either the test conditions are not appropriate or the test organisms are not healthy. In such a case the test should be stopped and repeated. Enchytraeids mainly live in the interstitial pores of the soil, and frequently their integument may be only partly in contact with the surrounding substrate; exposure of burrowing and non-burrowing enchytraeids is assumed to be equivalent and non-burrowing of the enchytraeids does not necessarily require the repetition of the test.

#### **Feeding**

36. Feeding should be envisaged when a soil with low total organic carbon content is used. When an artificial soil is used, a weekly feeding rate (i.e. the worms should be fed once a week) of 7 mg of dried dung per g soil dry weight is recommended for earthworms, and a weekly rate of 2-2,5 mg of ground oat flakes per g soil dry weight is recommended for enchytraeids (11). The first food ration should be mixed with the soil immediately before the test organisms are added. Preferably the same type of food like in the cultures should be used (see Appendix 5).

#### **Light and temperature**

37. The tests should be carried out under a controlled 16/8 hours light/dark cycle, preferably 400 to 800 lx in the area of the test vessels (3). The test temperature should be  $20 \pm 2$  °C throughout the test.

#### **Test concentrations**

38. A single concentration is used. Situations where additional concentration(s) is(are) required should be justified. If toxicity (EC<sub>x</sub>) of the test chemical is close to the analytical detection limit, the use of radiolabelled test chemical with high specific radioactivity is recommended. For metals, the concentration should be above the background level in tissue and soil.

#### **Replicates**

39. For the kinetic measurements (uptake and elimination phase), the minimum number of treated replicate vessels should be three per sampling point. The total number of replicates prepared should be sufficient to cover all sampling times during the uptake and the elimination phase.
40. For the biological observations and measurements (e.g. dry-to-wet weight ratio, lipid content) and for the analysis of background concentrations in worms and soil, at least 12 replicate vessels of a negative control (four sampled at start, four at end of uptake, and four at end of elimination) should be provided if no solvent other than water is used. If any solubilising agent is used for application of the test chemical, a solvent control (four replicate vessels should be sampled at start, four at the end of the uptake phase, and four at the end of the elimination phase) containing all constituents except for test item should be run in addition to the treated replicates. In this case, four additional replicate vessels of a negative control (no solvent) may also be provided for optional sampling at the end of the uptake phase. These replicates can be compared biologically with the solvent control in order to gain information on a possible influence of the solvent on the test organisms. It is recommended establishing a sufficient number of additional reserve replicate vessels (e.g. eight) for treatment and control(s).

#### Frequency of soil quality measurements

41. Soil pH, soil moisture content and the temperature (continuously) in the test room should be measured at the start and end of the uptake and elimination phases. Once per week the soil moisture content should be controlled by weighing the test vessels and comparing actual weights with initial weights at test start. Water losses should be compensated by adding deionised water.

#### Sampling and analysis of worms and soil

42. An example of schedule for the uptake and elimination phases in earthworm and enchytraeid bioaccumulation tests is given in Appendix 3.
43. The soil is sampled from the test vessels for the determination of test chemical concentration before inserting the worms, and during the uptake and elimination phases. During the test the concentrations of test chemical are determined in the worms and the soil. In general, total soil concentrations are measured. As an option, concentrations in pore water may be measured; in such case, rationale and appropriate methods should be provided prior to initiation of a study, and included in the report.
44. The worms and soil are sampled at least at six occasions during the uptake and the elimination phases. If the stability of a test chemical is demonstrated, the number of soil analyses can be reduced. It is recommended analysing at least three replicates at the beginning and at the end of the uptake phase. If the concentration in soil measured at the end of the uptake phase deviates from the initial concentration by more than 30 %, the soil samples taken at other dates should also be analysed.
45. Remove the worms of a given replicate from the soil at each sampling time (e.g. after spreading the soil of the replicate on a shallow tray and picking the worms using soft jewellers' tweezers), rinse them quickly with water in a shallow glass or steel tray. Remove excess water (see paragraph 34). Transfer the worms carefully to a pre-weighed vessel, weigh them instantly, including gut content.
46. The earthworms (*Eisenia* sp.) should then be allowed to purge their gut overnight e.g. on a moist filter paper in a covered petri dish (see paragraph 34). After purging, the weight of the worms should be determined in order to assess a possible decrease in biomass during the test (see validity criteria in paragraph 17). Weighing and tissue analysis of Enchytraeids is carried out without purging, as this is technically difficult due to the small size of these worms. After final weight determination, the worms should be killed immediately, using the most appropriate method (e.g. using liquid nitrogen, or freezing at temperatures below  $-18^{\circ}\text{C}$ ).
47. During the elimination phase, the worms replace contaminated gut contents with clean soil. This means, measurements in un-purged worms (enchytraeids in this context) sampled immediately before the elimination phase include contaminated gut soil. For aquatic oligochaetes it is assumed that after the initial 4-24 h of the elimination phase, most of the contaminated gut content has been replaced by clean sediment e.g. (46). Similar findings have been reported for earthworms in studies on the accumulation of radiolabelled cadmium and zinc (78). In the non-purged enchytraeids, the concentration of this first sample of the elimination phase may be considered as the tissue concentration after gut purge. To account for dilution of the test item concentration by uncontaminated soil during the elimination phase, the weight of the gut content may be estimated from worm wet weight/worm ash weight or worm dry weight/worm ash weight ratios.
48. The soil and worm samples should be preferably analysed immediately after removal (i.e. within 1-2 days) in order to prevent degradation or other losses, and it is recommended calculating the approximate uptake and elimination rates as the test proceeds. If the analysis is delayed, the samples should be stored by an appropriate method, e.g. by deep-freezing ( $\leq -18^{\circ}\text{C}$ ).
49. It should be checked that the precision and reproducibility of the chemical analysis, as well as the recovery of the test chemical from soil and worm samples are satisfactory for the given method; the extraction efficiency, the limit of detection (LOD) and the limit of quantification (LOQ) should be reported. Likewise it should be checked that the test chemical is not detectable in the control vessels in concentrations higher than background. When the concentration of the test chemical in the test organism  $C_a$  is  $> 0$  in the control worms, this should be included in the calculation of the kinetic parameters (see Appendix 2). All samples should be handled throughout the test to minimise contamination and loss (e.g. resulting from adsorption of the test chemical on the sampling device).



50. When working with radiolabelled test chemicals, it is possible to analyse parent and metabolites. Quantification of parent test chemical and metabolites at steady state or at the end of the uptake phase provides important information. The samples should then be “cleaned up” so that the parent test chemical can be quantified separately. If single metabolites exceed 10 % of total radioactivity in the analysed sample(s), the identification of these metabolites is recommended.
51. The overall recovery, and the recovery of test chemical in worms, soil, and if used, in traps containing absorbents to retain evaporated test chemical, should be recorded and reported.
52. Pooling of the individuals sampled from a given test vessel is acceptable for enchytraeid worms which are smaller than earthworms. If pooling involves the reduction of the number of replicates, this limits the statistical procedures which can be applied to the data. If a specific statistical procedure and power are required, then an adequate number of replicate test vessels should be included in the test to accommodate the desired pooling, procedure and power.
53. It is recommended that the BAF be expressed both as a function of total dry weight and, when required (i.e. for highly hydrophobic chemicals), as a function of the lipid content. Suitable methods should be used for determination of lipid content (some existing methods – e.g. (31) (58) – should be adapted for this purpose). These methods use a chloroform/methanol extraction technique. However, to avoid the use of chlorinated solvents, a modification of the Bligh and Dyer method (9) as described in (17) should be used. Since the various methods may not give identical values, it is important to give details of the method used. When possible, i.e. if sufficient worm tissue is available, the lipid analysis should ideally be made on the same sample or extract as the one used for analysis of the test chemical, since the lipids often have to be removed from the extract before it can be analysed chromatographically (49). Alternatively, control animals may be used to measure the lipid content, which can then be used to normalise BAF values. This latter approach reduces the contamination of equipment with the test chemical.

#### DATA AND REPORTING

##### Treatment of results

54. The uptake curve of the test chemical is obtained by plotting its concentration in/on the worms during the uptake phase against time on arithmetic scales. When the curve has reached a plateau, or steady state (see definitions in Appendix 1), the steady state bioaccumulation factor BAF<sub>ss</sub> is calculated from:

$$\frac{C_a \text{ at steady state or at end of uptake phase (mean)}}{C_s \text{ at steady state or at end of uptake phase (mean)}}$$

$C_a$  is the concentration of test chemical in the test organism

$C_s$  is the concentration of test chemical in the soil

55. When no steady state is reached, the BAF<sub>K</sub>, based on the rate constants, should be determined instead of BAF<sub>ss</sub>, as described below:

- Determine the accumulation factor (BAF<sub>K</sub>) as the ratio  $k_s/k_e$ .
- Uptake and elimination rates are preferably calculated simultaneously (see Equation 11 in Appendix 2)
- The elimination rate constant ( $k_e$ ) is usually determined from the elimination curve (i.e. a plot of the concentration of the test item in the worms during the elimination phase). The uptake rate constant  $k_s$  is then calculated given  $k_e$  and a value of  $C_a$  which is derived from the uptake curve – See Appendix 2 for a description of these methods. The preferred method for obtaining BAF<sub>K</sub> and the rate constants,  $k_s$ , and  $k_e$ , is to use non-linear parameter estimation methods on a computer. If the elimination is obviously not first-order, then more complex models should be employed.

##### Test report

56. The test report should include the following information:

*Test chemical:*

- Any available information on acute or long term toxicity (e.g. EC<sub>x</sub>, LC<sub>x</sub>, NOEC) of the test chemical towards soil-dwelling oligochaetes;
- purity, physical nature and, physicochemical properties e.g. log K<sub>ow</sub>, water solubility;
- chemical identification data; source of the test item, identity and concentration of any solvent used;
- if radiolabelled test chemical is used, the precise position of the labelled atoms, the specific radioactivity, and the radiochemical purity.

*Test species:*

- scientific name, strain, source, any pre-treatment, acclimation, age, size-range, etc..

*Test conditions:*

- test procedure used;
- type and characteristics of illumination used and photoperiod(s);
- test design (e.g. number and size of test vessels, soil mass and height of soil layer, number of replicates, number of worms per replicate, number of test concentrations, duration of uptake and elimination phases, sampling frequency);
- rationale for the choice of test vessel material;
- method of test item preparation and application as well as reasons for choosing a specific method;
- the nominal test concentrations, the means of the measured values and their standard deviations in the test vessels, and the method by which these values were obtained;
- source of the constituents of the artificial soil or – if natural media are used – origin of the soil, description of any pre-treatment, results of the controls (survival, biomass development, reproduction), soil characteristics (pH, total organic carbon content, particle size distribution (percent sand, silt, and clay), WHC<sub>max</sub>, percent water content at start and at end of the test, and any other measurements made);
- detailed information on the treatment of soil and worm samples, including details of preparation, storage, spiking procedures, extraction, and analytical procedures (and precision) for the test item in worms and soil, and lipid content (if measured), and recoveries of the test item.

*Results:*

- mortality of the control worms and the worms in each test vessel and any observed abnormal behaviour (e.g. soil avoidance, lack of reproduction in a bioaccumulation test with enchytraeids);
- the dry weight to wet weight ratio of the soil and the test organisms (useful for normalisation);
- the wet weights of the worms at each sampling time; for earthworms, the wet weights at start of the test, and at each sampling time before and after gut purging;
- the lipid content of the test organisms (if determined);



- curves, showing the uptake and elimination kinetics of the test chemical in the worms, and the time to steady state;
- $C_a$  and  $C_s$  (with standard deviation and range, if appropriate) for all sampling times ( $C_a$  expressed in  $\text{g kg}^{-1}$  wet and dry weight of whole body,  $C_s$  expressed in  $\text{g kg}^{-1}$  wet and dry weight of soil). If a biota-soil accumulation factor (BSAF) is required (e.g. for comparison of results from two or more tests performed with animals of differing lipid content),  $C_a$  may additionally be expressed as  $\text{g kg}^{-1}$  lipid content of the organism, and  $C_s$  may be expressed as  $\text{g kg}^{-1}$  organic carbon (OC) of the soil;
- BAF (expressed in  $\text{kg soil}\cdot\text{kg}^{-1}$  worm), soil uptake rate constant  $k_s$  (expressed in  $\text{g soil kg}^{-1}$  of worm  $\text{day}^{-1}$ ), and elimination rate constant  $k_e$  (expressed in  $\text{day}^{-1}$ ); BSAF (expressed in  $\text{kg soil OC kg}^{-1}$  worm lipid content) may be reported additionally;
- if measured: percentages of parent chemical, metabolites, and bound residues (i.e. the percentage of test chemical that cannot be extracted with common extraction methods) detected in soil and test animals;
- methods used for the statistical analyses of data.

*Evaluation of results:*

- compliance of the results with the validity criteria as listed in paragraph 17;
- unexpected or unusual results, e.g. incomplete elimination of the test chemical from the test animals.

LITERATURE:

- (1) Amorim M (2000). Chronic and toxicokinetic behavior of Lindane ( $\gamma$ -HCH) in the Enchytraeid *Enchytraeus albidus*. Master thesis, University Coimbra.
- (2) ASTM (2000). Standard guide for the determination of the bioaccumulation of sediment-associated contaminants by benthic invertebrates. American Society for Testing and Materials, E 1688-00a.
- (3) ASTM International (2004). Standard guide for conducting laboratory soil toxicity or bioaccumulation tests with the Lumbricid earthworm *Eisenia fetida* and the Enchytraeid potworm *Enchytraeus albidus*. ASTM International, E1676-04: 26 pp.
- (4) Beek B, Boehling S, Bruckmann U, Franke C, Joehncke U, Studinger G (2000). The assessment of bioaccumulation. In Hutzinger, O. (editor), The Handbook of Environmental Chemistry, Vol. 2 Part J (Vol. editor: B. Beek): Bioaccumulation — New Aspects and Developments. Springer-Verlag Berlin Heidelberg: 235-276.
- (5) Belfroid A, Sikkenk M, Seinen W, Van Gestel C, Hermens J (1994). The toxicokinetic behavior of chlorobenzenes in earthworms (*Eisenia andrei*): Experiments in soil. Environ. Toxicol. Chem. 13: 93-99.
- (6) Belfroid A, Van Wezel A, Sikkenk M, Van Gestel C, Seinen W & Hermens J (1993). The toxicokinetic behavior of chlorobenzenes in earthworms (*Eisenia andrei*): Experiments in water. Ecotox. Environ. Safety 25: 154-165.
- (7) Belfroid A, Meiling J, Drenth H, Hermens J, Seinen W, Van Gestel C (1995). Dietary uptake of superlipophilic compounds by earthworms (*Eisenia andrei*). Ecotox. Environ. Safety 31: 185-191.
- (8) Bell AW (1958). The anatomy of *Enchytraeus albidus*, with a key to the species of the genus *Enchytraeus*. Ann. Mus. Novitat. 1902: 1-13.
- (9) Bligh EG and Dyer WJ (1959). A rapid method of total lipid extraction and purification. Can. J. Biochem. Pysiol. 37: 911-917.
- (10) Bouche M (1972). Lombriciens de France. Ecologie et Systematique. INRA, Annales de Zoologie-Ecologie animale, Paris, 671 p.

- (11) Bruns E, Egeler Ph, Moser T, Römbke J, Scheffczyk A, Spörlein P (2001a). Standardisierung und Validierung eines Bioakkumulationstests mit terrestrischen Oligochaeten. Report to the German Federal Environmental Agency (Umweltbundesamt Berlin), R & D No.: 29864416.
- (12) Bruns E, Egeler Ph, Römbke J, Scheffczyk A, Spörlein P (2001b). Bioaccumulation of lindane and hexachlorobenzene by the oligochaetes *Enchytraeus luxuriosus* and *Enchytraeus albidus* (Enchytraeidae, Oligochaeta, Annelida). *Hydrobiologia* 463: 185-196.
- (13) Conder JM and Lanno RP (2003). Lethal critical body residues as measures of Cd, Pb, and Zn bioavailability and toxicity in the earthworm *Eisenia fetida*. *J. Soils Sediments* 3: 13-20.
- (14) Connell DW and Markwell RD (1990). Bioaccumulation in the Soil to Earthworm System. *Chemosphere* 20: 91-100.
- (15) Didden WAM (1993). Ecology of Terrestrial Enchytraeidae. *Pedobiologia* 37: 2-29.
- (16) Didden W (2003). Oligochaeta, In: Bioindicators and biomonitors. Markert, B.A., Breure, A.M. & Zechmeister, H.G. (eds.). Elsevier Science Ltd, The Netherlands, pp. 555-576.
- (17) De Boer J, Smedes F, Wells D, Allan A (1999). Report on the QUASH interlaboratory study on the determination of total-lipid in fish and shellfish. Round 1 SBT-2, Exercise 1000, EU, Standards, Measurement and Testing Programme.
- (18) Dietrich DR, Schmid P, Zweifel U, Schlatter C, Jenni-Eiermann S, Bachmann H, Bühler U, Zbinden N (1995). Mortality of birds of prey following field application of granular carbofuran: A Case Study. *Arch. Environ. Contam. Toxicol.* 29: 140-145.
- (19) Regulation (EC) No 1907/2006 of the European Parliament and of the Council of 18 December 2006 concerning the Registration, Evaluation, Authorisation and Restriction of Chemicals (REACH), establishing a European Chemicals Agency, amending Directive 1999/45/EC and repealing Council Regulation (EEC) No 793/93 and Commission Regulation (EC) No 1488/94 as well as Council Directive 76/769/EEC and Commission Directives 91/155/EEC, 93/67/EEC, 93/105/EC and 2000/21/EC (OJ L 396, 30.12.2006, p. 1).
- (20) Edwards CA and Bohlen PJ (1996). *Biology and ecology of earthworms*. Third Edition, Chapman & Hall, London, 426 pp.
- (21) OECD (2008), *Bioaccumulation in Sediment-dwelling Benthic Oligochaetes*, Test Guideline No 315, Guidelines for the testing of chemicals, OECD, Paris
- (22) Egeler Ph, Gilberg D, Scheffczyk A, Moser Th and Römbke J (2009). Validation of a Soil Bioaccumulation Test with Terrestrial Oligochaetes by an International Ring Test (Validierung einer Methode zur standardisierten Messung der Bioakkumulation mit terrestrischen Oligochaeten). Report to the Federal Environmental Agency (Umweltbundesamt Dessau-Rosslau), R & D No.: 20467458: 149 pp. Available for download at: <http://www.oecd.org/dataoecd/12/20/42552727.pdf>.
- (23) Elmgaard N and Jagers op Akkerhuis GAJM (2000). Safety factors in pesticide risk assessment, Differences in species sensitivity and acute-chronic relations. National Environmental Research Institute, NERI Technical Report 325: 57 pp.
- (24) Environment Canada (1995). Guidance document on measurement of toxicity test precision using control sediments spiked with a reference toxicant. Environmental Protection Series Report EPS 1/RM/30.
- (25) EPPO (2003). Environmental Risk Assessment scheme for plant protection products. Soil organisms and functions, EPPO (European Plant Protection Organization) Standards, Bull, OEPP/EPPO 33: 195-208.
- (26) Franke C (1996). How meaningful is the bioconcentration factor for risk assessment? *Chemosphere* 32: 1897-1905.

- (27) Franke C, Studinger G, Berger G, Böhling S, Bruckmann U, Cohors-Fresenborg D, Jöhncke U (1994). The assessment of bioaccumulation. *Chemosphere* 29: 1501-1514.
- (28) Füll C (1996). Bioakkumulation und Metabolismus von -1,2,3,4,5,6-Hexachlorcyclohexan (Lindan) und 2-(2,4-Dichlorphenoxy)-propionsäure (Dichlorprop) beim Regenwurm *Lumbricus rubellus* (Oligochaeta, Lumbricidae). Dissertation University Mainz, 156 pp.
- (29) Füll C, Schulte C, Kula C (2003). Bewertung der Auswirkungen von Pflanzenschutzmitteln auf Regenwürmer. UWSF — Z. Umweltchem, Ökotox. 15: 78-84.
- (30) Gabric A.J, Connell DW, Bell PRF (1990). A kinetic model for bioconcentration of lipophilic compounds by oligochaetes. *Wat. Res.* 24: 1225-1231.
- (31) Gardner WS, Frez WA, Cichocki EA, Parrish CC (1985). Micromethods for lipids in aquatic invertebrates. *Limnology and Oceanography* 30: 1099-1105.
- (32) Hawker DW and Connell DW (1988). Influence of partition coefficient of lipophilic compounds on bioconcentration kinetics with fish. *Wat. Res.* 22: 701-707.
- (33) Hund-Rinke K and Wiechering H (2000). Earthworm avoidance test for soil assessments: An alternative for acute and reproduction tests. *J. Soils Sediments* 1: 15-20.
- (34) Hund-Rinke K, Römbke J, Riepert F, Achazi R (2000). Beurteilung der Lebensraumfunktion von Böden mit Hilfe von Regenwurmtests. In: *Toxikologische Beurteilung von Böden*. Heiden, S., Erb, R., Dott, W. & Eisen-träger, A. (eds.), Spektrum Verl., Heidelberg. 59-81.
- (35) ISO 11268-2 (1998) Soil Quality – Effects of pollutants on earthworms (*Eisenia fetida*). Part 2: Determination of effects on reproduction.
- (36) Jaenike J (1982). "*Eisenia foetida*" is two biological species. *Megadrilogica* 4: 6-8.
- (37) Jager T (1998). Mechanistic approach for estimating bioconcentration of organic chemicals in earthworms (Oligochaeta). *Environ. Toxicol. Chem.* 17: 2080-2090.
- (38) Jager T, Sanchez PA, Muijs B, van der Welde E, Posthuma L (2000). Toxicokinetics of polycyclic aromatic hydrocarbons in *Eisenia andrei* (Oligochaeta) using spiked soil. *Environ. Toxicol. Chem.* 19: 953-961.
- (39) Jager T, Baerselman R, Dijkman E, De Groot AC, Hogendoorn EA, DeJong A, Kruitbosch JAW, Peijnenburg W J G. M (2003a). Availability of polycyclic aromatic hydrocarbons to earthworms (*Eisenia andrei*, Oligochaeta) in field-polluted soils and soil-sediment mixtures. *Environ. Toxicol. Chem.* 22: 767-775.
- (40) Jager T, Fleuren RLJ, Hoogendoorn E, de Korte G (2003b). Elucidating the routes of exposure for organic chemicals in the earthworm, *Eisenia andrei* (Oligochaeta). *Environ. Sci. Technol.* 37: 3399-3404.
- (41) Janssen MPM, Bruins A, De Vries TH, Van Straalen NM (1991). Comparison of cadmium kinetics in four soil arthropod species. *Arch. Environ. Contam. Toxicol.* 20: 305-312.
- (42) Kasprzak K (1982). Review of enchytraeid community structure and function in agricultural ecosystems. *Pedobiologia* 23: 217-232.
- (43) Khalil AM (1990). Aufnahme und Metabolismus von <sup>14</sup>C-Hexachlorbenzol und <sup>14</sup>C-Pentachlornitrobenzol in Regenwürmern. Dissertation University München, 137 pp.
- (44) Landrum PF (1989). Bioavailability and toxicokinetics of polycyclic aromatic hydrocarbons sorbed to sediments for the amphipod *Pontoporeia hoyi*. *Environ. Sci. Toxicol.* 23: 588-595.

- (45) Marinussen MPJC, Van der Zee SEATM, De Haan FA (1997). Cu accumulation in *Lumbricus rubellus* under laboratory conditions compared with accumulation under field conditions. *Ecotox. Environ. Safety* 36: 17-26.
- (46) Mount DR, Dawson TD, Burkhard LP (1999). Implications of gut purging for tissue residues determined in bioaccumulation testing of sediment with *Lumbriculus variegates*. *Environ. Toxicol. Chem.* 18: 1244-1249.
- (47) Nendza M (1991). QSARs of bioaccumulation: Validity assessment of log  $K_{ow}$ /log BCF correlations, In: R. Nagel and R. Loskill (eds.): Bioaccumulation in aquatic systems, Contributions to the assessment, Proceedings of an international workshop, Berlin 1990, VCH, Weinheim.
- (48) Chapter C.8 of this Annex, Toxicity for Earthworms
- (49) Chapter C.13 of this Annex, Bioconcentration: flow-through fish test.
- (50) Chapter C.21 of this annex, Soil Microorganisms: Nitrogen Transformation Test.
- (51) OECD (2004a), Enchytraeid reproduction test, Test Guideline No 220, Guidelines for the testing of chemicals, OECD, Paris.
- (52) OECD (2004b), Earthworm reproduction test (*Eisenia fetida*/*Eisenia Andrei*), Test Guideline No 222, Guidelines for the testing of chemicals, OECD, Paris.
- (53) OECD (2008), Bioaccumulation in Sediment-dwelling Benthic Oligochaetes, Test Guideline No 315, Guidelines for the testing of chemicals, OECD, Paris.
- (54) Petersen H and Luxton M (1982). A comparative analysis of soil fauna populations and their role in decomposition processes. *Oikos* 39: 287-388.
- (55) Phillips DJH (1993). Bioaccumulation. In: Handbook of Ecotoxicology Vol. 1. Calow P. (ed.). Blackwell Scientific Publ., Oxford. 378-396.
- (56) Pflugmacher J (1992). Struktur-Aktivitätsbestimmungen (QSAR) zwischen der Konzentration von Pflanzenschutzmitteln und dem Octanol-Wasser-Koeffizienten UWSF- Z. Umweltchem. Ökotox. 4: 77-81.
- (57) Posthuma L, Weltje L, Anton-Sanchez FA (1996). Joint toxic effects of cadmium and pyrene on reproduction and growth of the earthworm *Eisenia fetida*. RIVM Report No 607506001, Bilthoven.
- (58) Randall RC, Lee II H, Ozretich RJ, Lake JL, Pruell RJ (1991). Evaluation of selected lipid methods for normalising pollutant bioaccumulation. *Environ.Toxicol. Chem.* 10: 1431-1436.
- (59) Römbke J, Egele, P, Füll C (1998). Literaturstudie über Bioakkumulationstests mit Oligochaeten im terrestrischen Medium. UBA-Texte 28/98, 84 S.
- (60) Römbke J and Moser Th (1999). Organisation and performance of an international ring-test for the validation of the Enchytraeid reproduction test. UBA-Texte 4/99: 373 pp.
- (61) Römbke J, Riepert F, Achazi R (2000). Enchytraeen als Testorganismen, In: Toxikologische Beurteilung von Böden. Heiden, S., Erb, R., Dott, W. & Eisentraeger, A. (eds.). Spektrum Verl., Heidelberg. 105-129.
- (62) Romijn CA.FM, Luttik R, Van De Meent D, Slooff W, Canton JH (1993). Presentation of a General Algorithm to Include Effect Assessment on Secondary Poisoning in the Derivation of Environmental Quality Criteria, Part 2: Terrestrial food chains. *Ecotox. Envir. Safety* 27: 107-127.

- (63) Sample BE, Suter DW, Beauchamp JJ, Efrogmson RA (1999). LITERATURE-derived bioaccumulation models for earthworms: Development and validation. *Environ. Toxicol. Chem.* 18: 2110-2120.
- (64) Schlosser H-J and Riepert F (1992). Entwicklung eines Prüfverfahrens für Chemikalien an Bodenraubmilben (Gamasina), Teil 2: Erste Ergebnisse mit Lindan und Kaliumdichromat in subletaler Dosierung. *Zool. Beitr. NF* 34: 413-433.
- (65) Schmelz R and Collado R (1999). *Enchytraeus luxuriosus* sp. nov., a new terrestrial oligochaete species (Enchytraeide, Clitellata, Annelida). *Carolinae* 57: 93-100.
- (66) Sims R W and Gerard BM (1985). Earthworms, In: Kermack, D. M. & Barnes, R. S. K. (Hrsg.): *Synopses of the British Fauna (New Series) No 31.171*. S. London: E. J. Brill/Dr W. Backhuys.
- (67) Sousa JP, Loureiro S, Pieper S, Frost M, Kratz W, Nogueira AJA, Soares AMVM (2000). Soil and plant diet exposure routes and toxicokinetics of lindane in a terrestrial isopod. *Environ. Toxicol. Chem.* 19: 2557-2563.
- (68) Spacie A and Hamelink JL (1982). Alternative models for describing the bioconcentration of organics in fish. *Environ. Toxicol. Chem.* 1, 309-320.
- (69) Stephenson GL, Kaushik A, Kaushik NK, Solomon KR, Steele T, Scroggins RP (1998). Use of an avoidance-response test to assess the toxicity of contaminated soils to earthworms. In: *Advances in earthworm ecotoxicology*. S. Sheppard, J. Bembridge, M. Holmstrup, L. Posthuma (eds.). Setac Press, Pensacola, 67-81.
- (70) Sterenborg I, Vork NA, Verkade SK, Van Gestel CAM, Van Straalen NM (2003). Dietary zinc reduces uptake but not metallothionein binding and elimination of cadmium in the springtail *Orchesella cincta*. *Environ. Toxicol. Chemistry* 22: 1167-1171.
- (71) UBA (Umweltbundesamt) (1991). *Bioakkumulation — Bewertungskonzept und Strategien im Gesetzesvollzug*. UBA-Texte 42/91. Berlin.
- (72) US EPA (2000). *Methods for measuring the toxicity and bioaccumulation of sediment-associated contaminants with freshwater invertebrates*. Second Edition, EPA 600/R-99/064, US, Environmental Protection Agency, Duluth, MN, March 2000.
- (73) Van Brummelen TC and Van Straalen NM (1996). Uptake and elimination of benzo(a)pyrene in the terrestrial isopod *Porcellio scaber*. *Arch. Environ. Contam. Toxicol.* 31: 277-285.
- (74) Van Gestel CAM. (1992). The influence of soil characteristics on the toxicity of chemicals for earthworms; a review, In: *Ecotoxicology of Earthworms* (Ed. Becker, H, Edwards, PJ, Greig-Smith, PW & Heimbach, F). Intercept Press, Andover (GB).
- (75) Van Gestel CA and Ma W-C (1990). An approach to quantitative structure-activity relationships (QSARs) in earthworm toxicity studies. *Chemosphere* 21: 1023-1033.
- (76) Van Straalen NM, Donker MH, Vijver MG, van Gestel CAM (2005). Bioavailability of contaminants estimated from uptake rates into soil invertebrates. *Environmental Pollution* 136: 409-417.
- (77) Venter JM and Reinecke AJ (1988). The life-cycle of the compost-worm *Eisenia fetida* (Oligochaeta). *South African J. Zool.* 23: 161-165.
- (78) Vijver MG, Vink JPM, Jager T, Wolterbeek HT, van Straalen NM, van Gestel CAM (2005). Biphasic elimination and uptake kinetics of Zn and Cd in the earthworm *Lumbricus rubellus* exposed to contaminated floodplain soil. *Soil Biol, Biochem.* 37: 1843-1851.
- (79) Widianarko B and Van Straalen NM (1996). Toxicokinetics-based survival analysis in bioassays using nonpersistent chemicals, *Environ. Toxicol. Chem.* 15: 402-406.
-

## Appendix 1

## DEFINITIONS

**Bioaccumulation** is the increase in concentration of the test chemical in or on an organism relative to the concentration of the test chemical in the surrounding medium. Bioaccumulation results from both bioconcentration and biomagnification processes (see below).

**Bioconcentration** is the increase in concentration of the test chemical in or on an organism, resulting from the uptake of the chemical exclusively from the surrounding medium (i.e. via the body surface and ingested soil), relative to the concentration of the test chemical in the surrounding medium.

**Biomagnification** is the increase in concentration of the test chemical in or on an organism, resulting mainly from uptake from contaminated food or prey, relative to the concentration of the test chemical in the food or prey. Biomagnification can lead to a transfer or accumulation of the test item within food webs.

The **elimination** of a test chemical is the loss of this chemical from the test organism tissue by active or passive processes that occurs independently of presence or absence of the test item in the surrounding medium.

The **bioaccumulation factor** (BAF) at any time during the uptake phase of this bioaccumulation test is the concentration of test chemical in/on the test organism ( $C_a$  in  $\text{g}\cdot\text{kg}^{-1}$  dry weight of worm) divided by the concentration of the chemical in the surrounding medium ( $C_s$  as  $\text{g}\cdot\text{kg}^{-1}$  of dry weight of soil); the BAF has the units of  $\text{kg soil}\cdot\text{kg}^{-1}$  worm.

The **steady state bioaccumulation factor** ( $\text{BAF}_{ss}$ ) is the BAF at steady state and does not change significantly over a prolonged period of time, the concentration of the test chemical in the surrounding medium ( $C_s$  as  $\text{g}\cdot\text{kg}^{-1}$  of dry weight of soil) being constant during this period of time.

**Bioaccumulation factors** calculated directly from the ratio of the soil uptake rate constant and the elimination rate constant ( $k_s$  and  $k_e$ , see below) are termed kinetic bioaccumulation factor ( $\text{BAF}_k$ ).

The **biota-soil accumulation factor** (BSAF) is the lipid-normalised concentration of the test chemical in/on the test organism divided by the organic carbon-normalised concentration of the test chemical in the soil at steady state.  $C_a$  is then expressed as  $\text{g}\cdot\text{kg}^{-1}$  lipid content of the organism, and  $C_s$  as  $\text{g}\cdot\text{kg}^{-1}$  organic content of the soil; the BSAF has the units of  $\text{kg OC}\cdot\text{kg}^{-1}$  lipid.

A **plateau** or **steady state** is defined as the equilibrium between the uptake and elimination processes that occur simultaneously during the exposure phase. The steady state is reached in the plot of BAF against time when the curve becomes parallel to the time axis and three successive analyses of BAF made on samples taken at intervals of at least two days are within 20 % of each other, and there are no statistically significant differences among the three sampling periods. For test chemicals which are taken up slowly, more appropriate intervals would be seven days (49).

The **organic carbon-water partitioning coefficient** ( $K_{oc}$ ) is the ratio of a chemical's concentration in/on the organic carbon fraction of a soil and the chemical's concentration in water at equilibrium.

The **octanol-water partitioning coefficient** ( $K_{ow}$ ) is the ratio of a chemical's solubility in n-octanol and water at equilibrium, also sometimes expressed as  $P_{ow}$ . The logarithm of  $K_{ow}$  ( $\log K_{ow}$ ) is used as an indication of a chemical's potential for bioaccumulation by aquatic organisms.

The **uptake or exposure phase** is the time during which the test organisms are exposed to the test chemical.

The **soil uptake rate constant** ( $k_s$ ) is the numerical value defining the rate of increase in the concentration of the test item in/on the test organism resulting from uptake from the soil phase.  $k_s$  is expressed in  $\text{g soil}\cdot\text{kg}^{-1}$  of worm  $\text{d}^{-1}$ .

The **elimination phase** is the time, following the transfer of the test organisms from a contaminated medium to a medium free of the test item, during which the elimination (or the net loss) of the chemical from the test organisms is studied.

The **elimination rate constant** ( $k_e$ ) is the numerical value defining the rate of reduction in the concentration of the test item in/on the test organism, following the transfer of the test organisms from a medium containing the test item to a chemical-free medium;  $k_e$  is expressed in  $\text{d}^{-1}$ .

**Test chemical:** Any substance or mixture tested using this Test Method.

---

## Appendix 2

## Calculation of uptake and elimination parameters

The main endpoint of a bioaccumulation test is the bioaccumulation factor, BAF. The measured BAF can be calculated by dividing the concentration in the test organism,  $C_a$ , by the concentration in the soil,  $C_s$ , at steady state. If the steady state is not reached during the uptake phase, the  $BAF_K$  is calculated from the rate constants instead of BAFss. However, it should be noted if the BAF is based on steady state concentrations or not.

The usual means for obtaining the kinetic bioaccumulation factor ( $BAF_K$ ), the soil uptake rate constant ( $k_s$ ) and the elimination rate constant ( $k_e$ ) is to use non-linear parameter estimation methods on a computer, e.g. based on the models described in (68). Given a set of sequential time concentration data and the model equations:

$$C_a = \frac{k_s}{k_e} \times C_s(1 - e^{-k_e t}) \quad 0 < t < t_c \quad \text{[equation 1]}$$

or

$$C_a = \frac{k_s}{k_e} \times C_s(e^{-k_e(t-t_c)} - e^{-k_e t}) \quad t > t_c \quad \text{[equation 2]}$$

where:

$C_a$  = concentration of chemical in worms [g kg-1 wet or dry weight]

$k_s$  = uptake rate constant in tissue [g soil kg-1 of worm d-1]

$C_s$  = concentration of chemical in soil [g kg-1 of wet or dry weight]

$k_e$  = elimination rate constant [d-1]

$t_c$  = time at the end of the uptake phase,

these computer programs calculate values for  $BAF_K$ ,  $k_s$  and  $k_e$ .

When the background concentration in the non-exposed worms e.g. on day 0 differs significantly from zero (this may e.g. be the case for metals), this background concentration ( $C_{a,0}$ ) should be included in these equations, to make them read:

$$C_a = C_{a,0} + \frac{k_s}{k_e} \times C_s(1 - e^{-k_e t}) \quad 0 < t < t_c \quad \text{[equation 3]}$$

and

$$C_a = C_{a,0} + \frac{k_s}{k_e} \times C_s(e^{-k_e(t-t_c)} - e^{-k_e t}) \quad t > t_c \quad \text{[equation 4]}$$

In cases where a significant decrease of the test chemical concentration in the soil is observed over time during the uptake phase, the following models can be used e.g. (67) (79):

$$C_s = C_0(e^{-k_0 t}) \quad \text{[equation 5]}$$

where:

$C_s$  = concentration of chemical in the soil [g kg-1 wet or dry weight]

$k_0$  = degradation rate constant in soil [d-1]

$C_0$  = initial concentration of chemical in soil [g kg-1 of wet or dry weight]

$$C_a = \frac{k_s}{k_e - k_0} \times (e^{-k_0 t} - e^{-k_e t}) \quad 0 < t < t_c \quad \text{[equation 6]}$$



$$C_a = \frac{k_s}{k_e - k_0} \times e^{-k_0 t} - e^{-k} e^{t c} * e^{-k(t-t_c)} \quad t > t_c \quad \text{[equation 7]}$$

where:

$C_a$  = concentration of chemical in worms [g kg<sup>-1</sup> wet or dry weight]

$k_s$  = uptake rate constant in tissue [g soil kg<sup>-1</sup> of worm d<sup>-1</sup>]

$k_0$  = degradation rate constant in soil [d<sup>-1</sup>]

$k_e$  = elimination rate constant [d<sup>-1</sup>]

$t_c$  = time at the end of the uptake phase.

When steady state is reached during the uptake phase (i.e.  $t = \infty$ ), equation 1

$$C_a = \frac{k_s}{k_e} \times C_s (1 - e^{-k} e^{t c}) \quad 0 < t < t_c \quad \text{[equation 1]}$$

may be reduced to:

$$C_a = \frac{k_s}{k_e} \times C_s$$

or

$$C_a/C_s = k_s/k_e = \text{BAF}_K \quad \text{[equation 8]}$$

Then  $k_s/k_e \times C_s$  is an approach to the concentration of the test item in the worm tissue at steady state ( $C_{a,ss}$ ).

The biota-soil accumulation factor (BSAF) can be calculated as follows:

$$\text{BSAF} = \text{BAF}_K * \frac{f_{oc}}{f_{lip}} \quad \text{[equation 9]}$$

where  $f_{oc}$  is the fraction of soil organic carbon, and  $f_{lip}$  is the fraction of worm lipid, both preferably determined on samples taken from the test, and based either on dry weight or on wet weight, respectively.

The elimination kinetics can be modelled using the data from the elimination phase and applying the following model equation and a computer-based non-linear parameter estimation method. If the data points plotted against time indicate a constant exponential decline of the test item concentration in the animals, a one-compartment model (equation 9) can be used to describe the time course of elimination.

$$C_a(t) = C_{a,ss} \times e^{-k_e t} \quad \text{[equation 10]}$$

Elimination processes sometimes appear to be biphasic, showing a rapid decline of  $C_a$  during the early phases, that changes to a slower loss of test items in the later phases of the elimination, e.g. (27) (68). The two phases can be interpreted by the assumption, that there are two different compartments in the organism, from which the test item is lost with different velocities. In these cases, specific LITERATURE should be studied e.g. (38) (39) (40) (78).

Using the model equations above, the kinetic parameters ( $k_s$  and  $k_e$ ) may also be calculated in one run by applying the first order kinetics model to all data from both the uptake and elimination phase simultaneously. For a description of a method that may allow for such a combined calculation of uptake and elimination rate constants, references (41), (73) and (70) may be consulted.

$$C_a = \left[ \frac{K_s}{K_e} \cdot C_s (1 - e^{-k_e t}) \times (m = 1) \right] + \left[ \frac{K_s}{k_e} \times C_s (e^{-K_e(t-t_c)} - e^{-k_e t}) \times (m = 2) \right] \quad \text{[equation 11]}$$

*Note:* When uptake and elimination parameters are estimated simultaneously from the combined uptake and the elimination data, "m" as shown in equation 11 is a descriptor that allows the computer program to assign the equation's sub-terms to the data sets of the respective phase and to perform the evaluation correctly (m = 1 for uptake phase; m = 2 for elimination phase).

Nevertheless, these model equations should be used with caution, especially when changes in the test chemical's bio-availability, or (bio)degradation occur during the test (see e.g. (79)).



## Appendix 3

## EXAMPLES OF SCHEDULES FOR SOIL BIOACCUMULATION TESTS

**Earthworm test**

(a) Uptake phase with 8 sampling dates used for calculation of kinetics

Day	Activity
- 6	Conditioning of the prepared soil for 48 h;
- 4	Spiking of the soil fraction with the test chemical solution; evaporating of any solvent; mixing of the soil constituents; distributing the soil to the test vessels; equilibration at test conditions for 4 days (3 weeks for metal-spiked soil);
- 3 to - 1	Separation of the test organisms from the culture for acclimation; preparation and moisturising of the soil constituents;
0	Measuring temperature, and soil pH; removing soil samples from treated vessels and solvent controls for determination of test chemical concentration; addition of food ration; weighing and randomised distribution of the worms to the test vessels; retaining of sufficient subsamples of worms for determination of analytical background values, wet and dry weight, and lipid content; weighing of all test vessels to control soil moisture; controlling air supply, if closed test system is used;
1	Controlling air supply, recording worm behaviour and temperature; taking soil and worm samples for determination of test item concentration;
2	Same as day 1;
3	Controlling air supply, worm behaviour and temperature;
4	Same as day 1;
5-6	Same as day 3;
7	Same as day 1; addition of food ration; control soil moisture by re-weighing the test vessels and compensate evaporated water;
8-9	Same as day 3;
10	Same as day 1;
11-13	Same as day 3;
14	Same as day 1; addition of food ration; control soil moisture by re-weighing the test vessels and compensate evaporated water;
15-16	Same as day 3;
17	Same as day 1;
18-20	Same as day 3;
21	Same as day 1; measuring temperature and soil pH; control soil moisture by re-weighing the test vessels; end of uptake phase; transfer worms from remaining exposed replicates to vessels containing clean soil for elimination phase (no gut-purging); sampling of soil and worms from solvent controls.
	Pre-exposure activities (equilibration phase) should be scheduled taking into account the properties of the test chemical.
	Activities described for day 3 should be performed daily (at least on workdays).

## (b) Elimination phase

Day	Activity
- 6	Preparation and moisturising of the soil constituents; conditioning of the prepared soil for 48 h;
- 4	Mixing of the soil constituents; distributing the soil to the test vessels; incubation at test conditions for 4 days;
0 (end of uptake phase)	Measuring temperature and soil pH; weighing and randomised distribution of the worms to the test vessels; addition of food ration; transfer worms from remaining exposed replicates to vessels containing clean soil; taking soil and worm samples after 4-6 h for determination of test chemical concentration;
1	Controlling air supply, recording worm behaviour and temperature; taking soil and worm samples for determination of test chemical concentration;
2	Same as day 1;
3	Controlling air supply, worm behaviour and temperature;
4	Same as day 1;
5-6	Same as day 3;
7	Same as day 1; addition of food ration; control soil moisture by re-weighing the test vessels and compensate evaporated water;
8-9	Same as day 3;
10	Same as day 1;
11-13	Same as day 3;
14	Same as day 1; addition of food ration; control soil moisture by re-weighing the test vessels and compensate evaporated water;
15-16	Same as day 3;
17	Same as day 1;
18-20	Same as day 3;
21	Same as day 1; measuring temperature and soil pH; control soil moisture by re-weighing the test vessels; sampling of soil and worms from solvent controls.
	Preparation of the soil prior to start of elimination phase should be done in the same manner as before the uptake phase.
	Activities described for day 3 should be performed daily (at least on workdays).

**Enchytraeid test**

## (a) Uptake phase with 8 sampling dates used for calculation of kinetics

Day	Activity
- 6	Conditioning of the prepared soil for 48 h;
- 4	Spiking of the soil fraction with the test chemical solution; evaporating of any solvent; mixing of the soil constituents; distributing the soil to the test vessels; equilibration at test conditions for 4 days (3 weeks for metal-spiked soil);

Day	Activity
- 3 to - 1	Separation of the test organisms from the culture for acclimation; preparation and moisturising of the soil constituents;
0	Measuring temperature, and soil pH; removing soil samples from treated vessels and solvent controls for determination of test chemical concentration; addition of food ration to soil; weighing and randomised distribution of the worms to the test vessels; retaining of sufficient subsamples of worms for determination of analytical background values, wet and dry weight, and lipid content; weighing of all test vessels to control soil moisture; controlling air supply, if closed test system is used;
1	Controlling air supply, recording worm behaviour and temperature; taking soil and worm samples for determination of test item concentration;
2	Same as day 1;
3	Controlling air supply, worm behaviour and temperature;
4	Same as day 1;
5-6	Same as day 3;
7	Same as day 1; addition of food ration to soil; control soil moisture by re-weighing the test vessels and compensate evaporated water;
9	Same as day 1;
10	Same as day 3;
11	Same as day 1;
12-13	Same as day 3;
14	Same as day 1; addition of food ration to soil; measuring temperature and soil pH; control soil moisture by re-weighing the test vessels; end of uptake phase; transfer worms from remaining exposed replicates to vessels containing clean soil for elimination phase (no gut-purging); sampling of soil and worms from solvent controls.
	Pre-exposure activities (equilibration phase) should be scheduled taking into account the properties of the test chemical.
	Activities described for day 3 should be performed daily (at least on workdays).

## Appendix 4

**Artificial soil – preparation and storage recommendations**

Since natural soils from a particular source may not be available throughout the year, and indigenous organisms as well as the presence of micro-pollutants can influence the test, an artificial substrate, the artificial soil according to Chapter C.8 of this Annex, Toxicity for Earthworms (48), is recommended for use in this test. Several test species can survive, grow, and reproduce in this soil, and maximum standardisation as well as intra- and interlaboratory comparability of test and culture conditions are provided.

Soil constituents:

Peat:	10 %	Sphagnum-peat, in accordance with the OECD Guideline 207 (48);
Quartz sand:	70 %	Industrial quartz sand (air dried); grain size: more than 50 % of the particles should be in the range of 50-200 µm, but all particles should be ≤ 2 mm;
Kaolinite clay:	20 %	Kaolinite content ≥ 30 %;
Calcium carbonate:	≤ 1 %	CaCO <sub>3</sub> , pulverised, chemically pure.

As an option, the organic carbon content of the artificial soil may be reduced, e.g. by lowering the peat content to 4-5 % of dry soil and increasing the sand content accordingly. By such a reduction in organic carbon content, the possibilities of adsorption of test chemical to the soil (organic carbon) may be decreased, and the availability of the test chemical to the worms may increase (74). It has been demonstrated that *Enchytraeus albidus* and *Eisenia fetida* can comply with the validity criteria on reproduction when tested in field soils with lower organic carbon content, e.g. 2,7 % (33), (61), and there is experience that this can also be achieved in artificial soil with 5 % peat.

**Preparation**

The dry constituents of the soil are mixed thoroughly (e.g. in a large-scale laboratory mixer). This should be done about one week before starting the test. The mixed dry soil constituents should be moistened with deionised water at least 48 h before application of the test item in order to equilibrate/stabilise the acidity. For the determination of pH a mixture of soil and 1 M KCl solution in a 1:5 ratio is used. If the pH value is not within the required range ( $6,0 \pm 0,5$ ), a sufficient amount of CaCO<sub>3</sub> is added to the soil, or a new batch of soil is prepared.

The maximum water holding capacity (WHC) of the artificial soil is determined according to ISO 11268-2 (35). At least two days before starting the test, the dry artificial soil is moistened by adding enough deionised or reconstituted water to obtain approximately half of the final water content. The final water content should be 40 % to 60 % of the maximum WHC. At the start of the test, the pre-moistened soil is divided into as many batches as the number of test concentrations and controls used for the test, and the moisture content is adjusted to 40-60 % of WHC<sub>max</sub> by using the solution of the test item and/or by adding deionised or reconstituted water. The moisture content is determined at the beginning and at the end of the test (at 105 °C). It should be optimal for the species' requirements (the moisture content can also be checked as follows: when the soil is gently squeezed in the hand, small drops of water should appear between the fingers).

**Storage**

The dry constituents of the artificial soil may be stored at room temperature until use. The prepared, pre-moistened soil may be stored in a cool place for up to three days prior to spiking; care should be taken to minimise evaporation of water. Soil spiked with the test item should be used immediately unless there is information indicating that the particular soil can be stored without affecting the toxicity and bioavailability of the test item. Samples of spiked soil may then be stored under the conditions recommended for the particular test item until analysis.

## Appendix 5

**Species of terrestrial oligochaetes recommended for testing bioaccumulation from soil****Earthworms**

The recommended test species is *Eisenia fetida* (Savigny 1826), belonging to the family Lumbricidae. Since 1972 it is divided into two subspecies (*Eisenia fetida* and *Eisenia andrei* (10)). According to Jaenike (36), they are true, separate species. *Eisenia fetida* is easily recognised by its bright intersegmental yellow stripes whereas *Eisenia andrei* has a uniform, dark red colour. Originating probably from the region of the Black Sea, they are distributed worldwide today, especially in anthropogenically modified habitats like compost heaps. Both can be used for ecotoxicological as well as bioaccumulation tests.

*Eisenia fetida* and *Eisenia andrei* are commercially available, e.g. as fish bait. In comparison to other lumbricid earthworms, they have a short life-cycle, reaching maturity within ca. 2-3 months (at room temperature). Their optimum temperature is approximately at 20-24 °C. They prefer relatively moist substrates with a nearly neutral pH and a high content of organic material. Since these species have been widely used in standardised ecotoxicological tests for about 25 years, their culturing is well established (48) (77).

Both species can be bred in a wide range of animal wastes. The breeding medium recommended by ISO (35) is a 50:50 mixture of horse or cattle manure and peat. The medium should have a pH value of about 6 to 7 (regulated with calcium carbonate), a low ionic conductivity (less than 6 mS/cm or less than 0,5 % salt concentration) and should not be contaminated excessively with ammonia or animal urine. Also, a commercial gardening soil free of additives, or artificial soil according to OECD (48), or a 50:50 mixture of both can be used. The substrate should be moist but not too wet. Breeding boxes of 10 litre to 50 litre volume are suitable.

To obtain worms of standard age and mass, it is best to start the culture with cocoons. Therefore, adult worms are added to a breeding box containing fresh substrate to produce cocoons. Practical experience has shown that a population density of approximately 100 adult worms per kg substrate (wet weight) leads to good reproduction rates. After 28 days, the adult worms are removed. The earthworms hatched from the cocoons are used for testing when mature after at least 2 months but less than 12 months.

Worms of the species described above can be considered healthy if they move through the substrate, do not try to leave the substrate, and reproduce continuously. Very slow motioning or a yellow posterior end (in the case of *Eisenia fetida*) indicates substrate exhaustion. In this case, fresh substrate and/or a lower number of animals per box is recommended.

**Additional selected references**

Gerard BM (1964). Synopsis of the British fauna. No 6 Lumbricidae. Linnean Soc. London, 6: 1-58.

Graff O (1953). Die Regenwürmer Deutschlands. Schr. Forsch. Anst. Landwirtschaft. 7: 1-81.

Römbke J, Egeler P, Füll C (1997). Literaturstudie über Bioakkumulationstests mit Oligochaeten im terrestrischen Medium. Bericht für das UBA F + E 206 03 909, 86 S.

Rundgren S (1977). Seasonality of emergence in lumbricids in southern Sweden. Oikos 28: 49-55.

Satchell JE (1955). Some aspects of earthworm ecology. Soil Zoology (Kevan): 180-201.

Sims RW and Gerard BM (1985). A synopsis of the earthworms. Linnean Soc. London 31: 1-171.

Tomlin AD (1984). The earthworm bait market in North America. In: Earthworm Ecology — from Darwin to vermiculture. Satchell, J.E. (ed.), Chapman & Hall, London. 331-338 pp.

**Enchytraeids**

The recommended test species is *Enchytraeus albidus* Henle 1837 (white potworm). *Enchytraeus albidus* is one of the biggest (up to 15 mm) species of the annelid oligochaete family Enchytraeidae and it is worldwide distributed e.g. (8). *Enchytraeus albidus* is found in marine, limnic and terrestrial habitats, mainly in decaying organic matter (seaweed, compost) and rarely in meadows (42). This broad ecological tolerance and some morphological variations indicate that there might be different races for this species.

*Enchytraeus albidus* is commercially available, sold as food for fish. It should be checked whether the culture is contaminated by other, usually smaller species (60). If contamination occurs, all worms should be washed with water

in a Petri dish. Large adult specimens of *Enchytraeus albidus* are then selected (by using a stereomicroscope) to start a new culture. All other worms are discarded. Its life cycle is short as maturity is reached between 33 days (at 18 °C) and 74 days (at 12 °C). Only cultures which have been kept in the laboratory for at least 5 weeks (one generation) without problems should be used for a test.

Other species of the *Enchytraeus* genus are also suitable, especially *Enchytraeus luxuriosus*. This species is a true soil inhabitant, which has been newly described in (65). If other species of *Enchytraeus* are used, they should be clearly identified and the rationale for the selection of the species should be reported.

*Enchytraeus crypticus* (Westheide & Graefe 1992) is a species belonging to the same group as *Enchytraeus luxuriosus*. It has not been found to exist with certainty in the field, having only been described from earthworm cultures and compost heaps (Römbke 2003). Its original ecological requirements are therefore not known. However, recent laboratory studies in various field soils have confirmed that this species has a broad tolerance towards soil properties like pH and texture (Jänsch et al. 2005). In recent years, this species has often been used in ecotoxicological studies because of the simplicity of its breeding and testing, e.g. Kuperman et al. 2003). However, it is small (3-12 mm; 7 mm on average (Westheide & Müller 1996), and this makes handling more difficult compared with *Enchytraeus albidus*. When using this species instead of *Enchytraeus albidus*, the size of the test vessel can but needs not to be smaller. In addition, it should be considered that this species reproduces very rapidly having a generation time of less than 20 days at 20 ± 2 °C (Achazi et al. 1999) and even quicker at higher temperatures.

Enchytraeids of the species *Enchytraeus albidus* (as well as other *Enchytraeus* species) can be bred in large plastic boxes (e.g. 30 × 60 × 10 cm or 20 × 12 × 8 cm which is suitable for culture of worms of small size) filled with a mixture of artificial soil and commercially available, uncontaminated garden soil free of additives. Compost material should be avoided since it could contain toxic chemicals like heavy metals. Fauna should be removed from the breeding soil before use by three times deep-freezing. Pure artificial soil can also be used but the reproduction rate could be slower compared to that obtained with mixed substrates. The substrate should have a pH of 6,0 ± 0,5. The culture is kept in an incubator at a temperature of 15 ± 2 °C without light. In any case, a temperature higher than 23 °C should be avoided. The artificial/natural soil moisture should be moist but not wet. When the soil is gently pressed by hand, only small drops of water should appear. In any case, anoxic conditions should be avoided (e.g. if a lid is used, the number of lid holes should be high enough to provide sufficient exchange of air). The breeding soil should be aerated by carefully mixing it once per week.

The worms should be fed at least once per week ad libitum with rolled oats which are placed into a cavity on the soil surface and covered with soil. If food from the last feeding date remains in the container, the amount of food given should be adjusted accordingly. If fungi grow on the remaining food, it should be replaced by a new quantity of rolled oats. In order to stimulate reproduction, the rolled oats may be supplemented with commercially available, vitamin amended protein powder every two weeks. After three months, the animals are transferred to a freshly prepared culture or breeding substrate. The rolled oats, which have to be stored in sealed vessels, should be autoclaved or heated before use in order to avoid infections by flour mites (e.g. *Glyzyphagus* sp., Astigmata, Acarina) or predacious mites (e.g. *Hypoaspis (Cosmolaelaps) miles*, Gamasida, Acarina). After disinfecting, the food is ground up so that it can easily be strewn on the soil surface. Another possible food source is baker's yeast or the fish food TetraMin®.

In general, the culturing conditions are sufficient if worms do not try to leave the substrate, move quickly through the soil, exhibit a shiny outer surface without soil particles clinging to it, are more or less whitish coloured, and if worms of different ages are visible. Actually, worms can be considered healthy if they reproduce continuously.

#### Additional selected references

Achazi RK, Fröhlich E, Henneken M, Pilz C (1999). The effect of soil from former irrigation fields and of sewage sludge on dispersal activity and colonizing success of the annelid *Enchytraeus crypticus* (Enchytraeidae, Oligochaeta). Newsletter on Enchytraeidae 6: 117-126.

Jänsch S, Amorim MJB, Römbke J (2005). Identification of the ecological requirements of important terrestrial ecotoxicological test species. Environ. Reviews 13: 51-83.

Kuperman RG, Checkai RT, Simini M, Phillips CT, Kolakowski JE, Kurnas CW, Sunahara GI (2003). Survival and reproduction of *Enchytraeus crypticus* (Oligochaeta, Enchytraeidae) in a natural sandy loam soil amended with the nitro-heterocyclic explosives RDX and HMX. Pedobiologia 47: 651-656.

Römbke J (2003). Ecotoxicological laboratory tests with enchytraeids: A review. Pedobiologia 47: 607-616.

Westheide W and Graefe U (1992). Two new terrestrial *Enchytraeus* species (Oligochaeta, Annelida). J. Nat. Hist. 26: 479-488.

Westheide W and Müller MC (1996). Cinematographic documentation of enchytraeid morphology and reproductive biology. Hydrobiologia 334: 263-267.