



HELLENIC REPUBLIC
MINISTRY FOR THE ENVIRONMENT, ENERGY & CLIMATE CHANGE

THE MINISTER

Athens, 9 April 2012

Ref.Nr. Y.P.E.K.A./S.E.S.oik.: 197495

To: Republic of Bulgaria
Ministry of Environment
& Water

Subject: Notification of Environmental Impact Assessment (EIA) under the Espoo Convention for the investment proposal for the project : "Construction of a Natural Gas Pipeline Interconnector Greece-Bulgaria"

Dear Madam,

we are sending the present letter in order to notify you that a file for a Preliminary Impact Assessment Study concerning an Environmental Impact Assessment (EIA) process for the investment proposal for the project "Construction of a Natural Gas Pipeline Interconnector Greece-Bulgaria" has been submitted to the Hellenic Ministry for Environment Energy & Climate Change, according to the relevant provisions of Article 3 of the ECE Convention on Environmental Impact Assessment in a Transboundary Context (Espoo Convention) and the Article 7 of the 2011/92/EU Directive on the assessment of the effects of certain public and private projects on the environment (Codification of the 85/337/EEC Directive and its amendments).

The proponent of the project is "ICGB (Interconnector Greece-Bulgaria) A.D."

It would be very important for us to know whether your country would be interested in participating in the EIA process and in entering in bilateral consultations with Greece about this specific project.

Furthermore, we would like to encourage you to inform us of any particularly sensitive environmental or social issues that might be affected in the region and should be taken into account.

We would appreciate if you could let us know the contact details of the authority or person in charge for such matters. We would also like to know if you consider necessary to provide specific local data and arrange a contact point for the competent environmental authorities.

In any case, a positive or negative response will be required from you (whether or not you would like to participate in the EIA process and the relevant consultations) within four (4) weeks upon receipt of this letter.

In this direction, you may find attached to our letter a completed "Format for Notification under Article 3 of the ECE Convention on EIA in a Transboundary Context" for the Natural Gas Pipeline Interconnector Greece-Bulgaria containing all the necessary technical details (a non-technical summary, which includes a brief project description, project map and preliminary information on potential environmental impacts combined with suitable mitigation measures, as well as additional related information) for the proposed project, in order to proceed with the transboundary EIA procedure.

We will be looking forward to receiving your response.

Yours sincerely,

**THE HELLENIC MINISTER FOR
THE ENVIRONMENT, ENERGY & CLIMATE CHANGE**

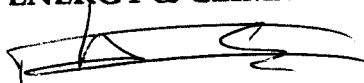

G. PAPA KONSTANTINOU

ATTACHMENT:

A completed format for
Notification under Article 3 of the
ECE Convention on EIA in a
Transboundary Context for the
Natural Gas Pipeline Interconnector
Greece-Bulgaria

FORMAT FOR NOTIFICATION UNDER ARTICLE 3 OF
THE ECE CONVENTION ON ENVIRONMENTAL IMPACT
IN A TRANSBOUNDARY CONTEXT

NOTIFICATION TO AN AFFECTED PARTY OF A PROPOSED ACTIVITY
UNDER ARTICLE 3 OF THE CONVENTION

1. INFORMATION ON THE PROPOSED ACTIVITY	
(i) Information on the nature of the proposed activity	
Type of activity proposed	<p>Construction and operation of the natural gas Interconnector Greece – Bulgaria (IGB) between Komotini in Greece and Stara Zagora in Bulgaria. The present notification concerns the Greek part, i.e. the section between Komotini area and the Greek-Bulgarian borders.</p> <p>The relevant section comprises mainly the following infrastructure:</p> <ul style="list-style-type: none"> -a pipeline, with an approximate length of 30 km, -the gas Metering Station, at the starting point in Komotini area, accompanied by other ancillary facilities (pigging station, etc) -a valve pit, located a few kilometers from the Greek Bulgarian borders.
Is the proposed activity listed in Appendix I to the Convention?	YES
Scope of proposed activity (e.g. main activity and any/all peripheral activities requiring assessment)	<p>Conduct all necessary works and field activities for constructing, installing and testing the gas interconnection infrastructure (pipeline and other ancillary infrastructures) between Komotini-Greece and Stara Zagora- Bulgaria. Temporary roads necessary for access to the route of the pipeline are also included.</p>
Scale of proposed activity (e.g. size, production capacity, etc.)	<p>The gas pipeline has a total length of approximately 181 km, approximately 30 Km of which are on Greek territory and 151 km on the Bulgarian territory. The gas pipeline diameter is 28" (711,2mm) up to 32" (812.8mm), to be confirmed by the FEED.</p> <p>The pipeline capacity is envisaged to be 3 bcm/year, with a potential increase to approximately 5 bcm/year.</p>

<p>Description of proposed activity (e.g. technology used)</p>	<p>The main activity is the pipeline construction which will be conducted through laying the pipeline below ground at approx. 1m below the surface.</p> <p>In respect of the crossing of the main road from Makasa to Egnatia, the laying of the pipeline below it will be conducted through horizontal directional drilling (HDD). If the HDD is not applicable, other appropriate technical solutions will be adopted.</p> <p>The pipeline will be designed and constructed based on the National, European and International codes and standards.</p>
<p>Description of purpose of proposed activity</p>	<p>The construction of the IGB will supply Bulgaria with natural gas from alternative sources such as the Caspian region and the Middle East. Moreover, IGB will be designed so as to have a reverse flow operation (from Bulgaria to Greece).</p>
<p>Rationale for proposed activity (e.g. socio-economic, physical geographic basis)</p>	<p>IGB will be another independent source for supply of natural gas to the Republic of Bulgaria, which will increase the security of supply and create opportunities for gas supply to new regions through which the route will run.</p> <p>Moreover, the geostrategic role of Greece and Bulgaria will be reinforced, since the transported quantities can also potentially supply other Balkan countries, through existing or scheduled interconnectors (e.g. Romania, Western Balkans). The IGB project has been declared as of National Importance by both the sovereign Countries involved through Resolution No 615/14.07.2009 of the Government of the Republic of Bulgaria and Law 4001/2011 of the Republic of Greece.</p>
<p>Additional information/comments</p>	

<p>(ii) Information on the spatial and temporal boundaries of the proposed Activity</p>	
<p>Location</p>	<p>The construction of IGB in the territory of the Republic of Greece will take place within the boundaries of the Municipality of Komotini, in the Region of Rodopi.</p>
<p>Description of the location (e.g. physical-geographic, socio-economic characteristics)</p>	<p>The Greek part of the route starts at the Industrial Area of Komotini and for its first part passes through level agricultural areas. The routing area then becomes hilly and in the last section, before reaching the Greek-Bulgarian border, it becomes mountainous. The route has been selected in order</p>

	to avoid archaeological sites, existing villages or settlements and to cross the minimum possible of forest areas. In general the route is in rather sparsely populated areas.
Rationale for location of proposed activity(e.g. socio-economic, physical-geographic basis)	The approach is to assure the full sustainability of the infrastructure with particular care to environmental protection by avoiding to the maximum extent possible crossing or passing through sites presenting geological or geotechnical difficulties, and by minimizing its total length. The Greek route does not cross any NATURA protected area/zone.
Time-frame for proposed activity (e.g. start and duration of construction and operation)	Front End Engineering Design & Environmental Impact Assessment Study has commenced in 2011. It is expected that the Detailed Design and Construction will be completed by the end of 2014. Lifetime of operation – 40 years.
Maps and other pictorial documents connected with the information on the proposed activity	Herewith attached is a map of proposed and alternative(s) route options in relation to the Project.
Additional information/comments	

(iii) Information on expected environmental impacts and proposed mitigation Measures	
Scope of assessment (e.g. consideration of: cumulative impacts, evaluation of alternatives, sustainable development issues, impact of peripheral activities, etc.)	The relevant National and European legislation is applicable, including the recently voted law 4014/2011. The Preliminary Definition of Environmental Requirements (an activity which is optional in the new law) has taken place with the submission of the Preliminary Environmental Impact Assessment Study (PEIAS). The Environmental Impact Assessment will follow, considering, among others, the following: allowed land uses; location, design and technical characteristics of the project, during its construction and operation; evaluation of alternative routes; data of the natural and anthropogenic environment; evaluation and assessment of potential significant impact to the environment during both construction and operation; mitigation measures, in order to delete, reduce and counterbalance any potential significant negative impacts; environmental management and monitoring; specialized studies, to be performed in the above mentioned Environmental Studies.

<p>Expected environmental impacts of proposed activity(e.g. types, locations, magnitudes)</p>	<p>During construction-installation works, the level of noise is expected to be temporary increased, due to the activities of construction machinery and workers. The operation of construction machinery is expected to lead to increase of the concentration of CO₂ in the atmosphere. It is also expected that limited discharge at specified suitable points of used lubricating oils will take place.</p> <p>During the construction of the IGB, construction corridors will have an expected width of 22m. In the above mentioned area, the vegetation shall be temporarily cleared. Following the pipeline installation, the reinstatement of the area will take place. In a zone 5m wide from each side of the pipeline axis, no deep root plants will be allowed. The impact of the construction to the flora is considered as not significant, local and permanent.</p> <p>Due to the significant volume of ground works necessary for the gas pipeline bedding, the mechanical effect on soils is the most significant one compared to all the other effects. The impact on soils could be assessed as significant, local (at construction site), short-term during construction, possible to reclaim and without cumulative effect.</p>
<p>Inputs (e.g. raw material, power sources, etc.)</p>	<p>During implementation of construction, small quantities of concrete shall be incorporated. The necessary electric energy for welding and other works will be provided by mobile diesel generators. In general, water will not be used for the pipeline construction and installation works. Water will be necessary for the performance of the hydraulic testing of the pipeline, following which, the water will be discharged in the nearest water basin.</p>
<p>Outputs(e.g. amounts and types of: emissions into the atmosphere, discharges into the water system, solid waste)</p>	<p>During construction of the IGB, the following types of emissions are expected:</p> <ul style="list-style-type: none"> -dust – during construction works (mainly from earth digging and reinstating works along the pipeline route and the at the stations)- “non-organized source” -emissions from the engines of construction machinery, construction processes and transportation of raw and other materials, equipment and staff. <p>During construction, transmission pipelines are stress tested (hydrotested) according to standards EN 1594, EN 12186, EN 12327. During hydrotesting, water does not change its volume,</p>

	<p>but its quality deteriorates due to the presence of construction byproducts (corrosion on the internal pipe surface, remains of welding electrodes, soil and other objects). The used water can be classified as waste water from a technological process – testing. For example, its volume for a section of 30 km of 32” is approximately 15.000 m³. Following hydrotesting, the used water has to be disposed off into a flowing stream or still water reservoir, following its proper cleaning.</p> <p>During the implementation of construction and installation works, small quantities of industrial and household waste will be generated, which will not impact negatively on the environment.</p> <p>During the operation of the Project, no significant impacts are expected.</p>
Transboundary impacts (e.g. types, locations, magnitudes)	Therefore, during construction and operation no transboundary impact is expected to occur.
Proposed mitigation measures (e.g. if known, mitigation measures to prevent, eliminate, minimize, compensate for environmental effects)	During the reinstatement of the area, the proper attention will be given to minimize the impacts, eg the top soil layer in agricultural areas will be kept separately and be used for the top layer during reinstatement. Reforestation will take place in areas outside the pipeline protection zone, etc.
Additional information/comments	

(iv) Proponent/developer	
Name, address, telephone and fax numbers	<p>Project Company - “ICGB” AD</p> <p>Company Headquarters: Sofia, Lyulin 2, „Pancho Vladigerov” Blvd. №66;</p> <p>Executive Officers: Mrs. Yuliana Dimitrova, Mr. Konstantinos Karagiannakos</p> <p>Postal Address: Sofia-1336, PO.BOX 3, Lyulin 2 “Pancho Vladigerov” №66;</p> <p>Phone and fax: phone: 0035/2/939 62 37, fax: 0035/2/936 65 05;</p> <p>Contact person in Greece: Mr G. Kostopoulos, Deputy Project Manager, tel 210 2701144</p>

(v) EIA documentation	
Is the EIA documentation (e.g. EIA report or EIS) included in the notification?	The Executive Summary of the PEIAS is herewith attached.

If no/partial, description of additional documentation to be forwarded and (approximate)date(s) when documentation will be available	
Additional information/comments	
2. POINTS OF CONTACT	

(i) Points of contact for the possible affected Party or Parties	
Authority responsible for coordinating activities relating to the EIA (refer to decision I/9, annex) - Name, address, telephone and fax numbers	Greek Ministry for the Environment, Energy and Climate Change- Republic of Greece (Ministry of Foreign Affairs - Greece)
List of affected Parties to which notification is being sent	
(ii) Points of contact for the Party of origin	
Authority responsible for coordinating activities relating to the EIA (refer to decision I/9, annex) - Name, address, telephone and fax numbers	Greek Ministry of Environment, Energy and Climate Change- Republic of Greece, Special Department of Environment, Director Mr Toleris, tel. 210 - 6412370, fax 210-6451914 (Through the Ministry of Foreign Affairs)
Decision-making authority if different than authority responsible for coordinating activities relating to the EIA - Name, address, telephone and fax numbers	

3. INFORMATION ON THE EIA PROCESS IN THE COUNTRY WHERE THE PROPOSED ACTIVITY IS LOCATED

(i) Information on the EIA process that will be applied to the proposed Activity	
Time schedule	<p>The Preliminary Environmental Impact Assessment Study (PEIAS) has been submitted in November 2011 and was communicated by the competent Ministry to the relevant Authorities. The replies received so far are positive and a positive consultation is expected to be issued in approximately 1 month.</p> <p>Taking into consideration the comments expressed to the PEIAS and other data from the FEED, the Environmental Impact Assessment Study (EIAS) is expected to be submitted by July 2012. Its approval is expected by the end of 2012.</p>
Opportunities for the affected Party or Parties to be involved in the EIA process	Concerning the PEIAS, the relevant Authorities have been requested to express their opinion. Moreover, following the issuance of the consultation of the competent Ministry for the

	<p>PEIAS, the public is informed about it through announcements to the press.</p> <p>Concerning the EIAS, the public is informed about the Project and the relevant Study is made available to them. The public can express its opinion, through the Regional and Municipality Councils or directly to the Ministry. The relevant comments, as well as possible clarifications by the Owner are considered by the competent Authority which, in case of approval, defines the environmental conditions for the Project.</p> <p>Following the issuance of the Environmental terms, the public is also informed about them.</p>
<p>Opportunities for the affected Party or Parties to review and comment on the notification and the EIA documentation</p>	<p>The administrative Authorities (Municipal, Regional) as well as the public will review and comment the documentation, according to the legal provisions:</p> <ul style="list-style-type: none"> - Following the approval of the PEIAS, a copy of the Study is communicated to the local Region. - During the EIAS consultation, the EIAS is made available to the Authorities and the public. - Following the issuance of the Environmental Terms, the relevant Decision is made available in a dedicated internet site.
<p>Nature and timing of the possible decision</p>	<p>The indicative time period for the receipt of the EIA Decision is by the end of 2012.</p>
<p>Process for approval of the proposed activity</p>	<p>The Ministry for the Environment, Energy and Climate Change is the competent authority to issue the EIA decision. The following steps shall be followed as per requirements of the Greek legal framework:</p> <ul style="list-style-type: none"> - Submission of the Report for the Preliminary Definition of Environmental Requirements to the Ministry and issuance of the relevant consultation by the Ministry (optional activity, which has been decided to be followed) - Submission of EIA Report to the Ministry; - assessment of EIA Report by the Ministry - Public information to the affected municipalities, in order to express their comments; - Issuance of final decision by the Ministry.
<p>Additional information/comments</p>	

4. INFORMATION ON THE PUBLIC PARTICIPATION PROCESS IN THE COUNTRY OF ORIGIN

<p>Public participation procedures</p>	<p>The EIA Report shall be made available to the public. Each citizen can submit his comments, either directly or through the local (regional and municipal) authorities. The local authorities will then issue their consultation</p>
<p>Expected start and duration of public consultation</p>	<p>The two Studies (Preliminary Definition of Environmental Requirements and Environmental Impact Assessment Study) will be made available to the public.</p> <p>The first one has been submitted to the competent Ministry at the end of November 2011 and the second one is expected to be completed within July 2012.</p> <p>A period of 5 months is estimated for the approval of the EIA, following its submission.</p>
<p>Additional information/comments</p>	

5. DEADLINE FOR RESPONSE

<p>Date</p>	
-------------	--

2.

Executive Summary of the Preliminary Environmental Impact Assessment Study (PEIAS) for the Greek Section of IGB

2.1

General Considerations

ICGB AD is a company incorporated with the scope of financing, developing, building, owning and operating on a long-term basis the gas interconnector between Greece and Bulgaria (the "Gas Interconnector Greece-Bulgaria" or "IGB Project"). The shareholders of ICGB are the Bulgarian company BEH 50% and IGI Posidon 50% (i.e DEPA 25% and Italian EDISON SpA 25% since they are equal shareholders of IGI Posidon).

The IGB buried pipeline will transport natural gas over the border between Greece and Bulgaria, connecting the existing Komotini Compressor Station in Greece with an existing gas pipeline near the Bulgarian town of Stara Zagora. The proposed pipeline will measure a total distance of approximately **180 Km**, (about **30 Km in Greece** and **150 Km in Bulgaria**).

The design of this bi-directional pipeline system shall be in accordance with the internationally recognised codes of practice: EN1594 and ASME B31.8, and also in conjunction with Bulgarian Ordinances, for the safe transportation of **3bcm/yr** of gas initially, with the provision for the future expansion up to a maximum technical capacity of **5bcm/yr**.

The following is a summary of the main components of the project:

- High pressure gas transmission pipeline of nominal OD 28" (711,2 mm) or larger according with the FEED between Komotini and Stara Zagora in Bulgaria; Greek part about 30 Km and Bulgarian Part about 150 Km.
- At least seven (7) Block Valve Stations (BVs) along the route of the pipeline, in compliance with applicable norms, one (1) in Greece and at least six (6) in Bulgaria.
- Gas Metering Station (GMS) Komotini and Pigging Launcher Station (PS) in Komotini
- Metering and Pressure Reducing Station in Kardjali, Bulgaria ;
- Metering and Pressure Reducing Station in Haskovo, Bulgaria;
- Gas pipeline connection along with metering and Pressure Regulating Station in Dimitrovgrad Bulgaria;
- Gas Metering Station (GMS) and Pigging Receiver Station (PS) in Stara Zagora Bulgaria;
- Integrated Control and telecommunication systems.
- Dispatch Center and operation and maintenance base in suitable location in Bulgaria.
- Provision for future compressor facilities
- Various ancillary facilities to support the abovementioned infrastructure.

Figure 2.1 Schematic Drawing of the IGB Project

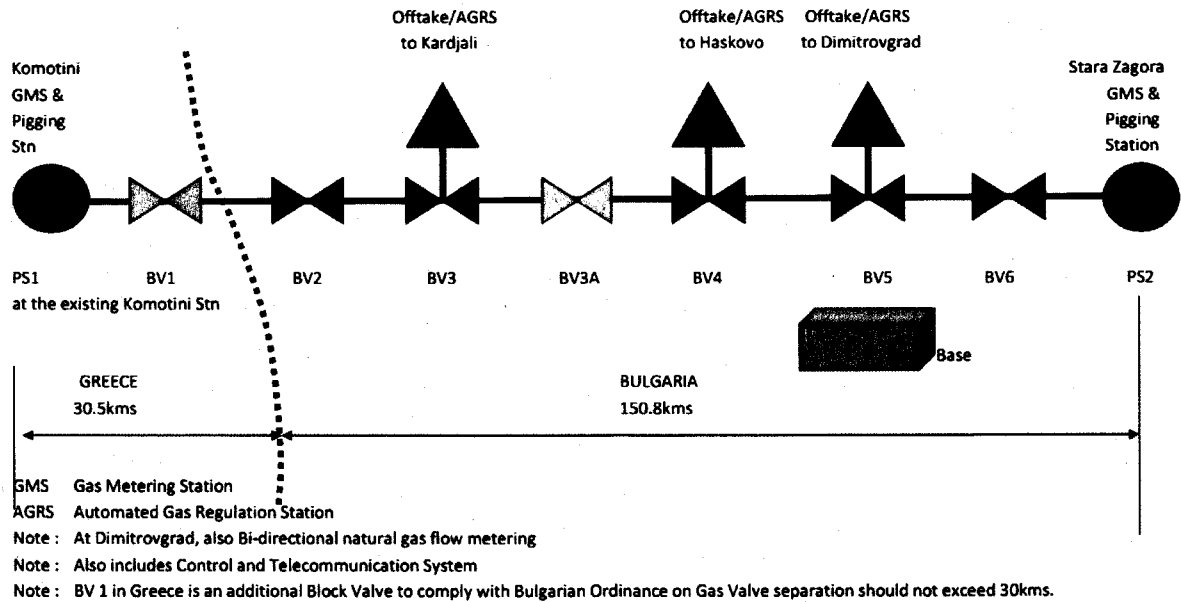

The present document comprises the Preliminary Environmental Impact Assessment (PEIA) Study regarding the Greek Part of the IGB Project. In specific, the study covers the part of the pipeline from Komotini to the Greek-Bulgarian border, including the Gas Metering Station (GMS) Komotini and Pigging Station (PS) Komotini along with all the necessary auxiliary equipment and the first Block Valve Station (BVs) that will be installed in the Greek Territory.

The present Preliminary Environmental Impact Assessment Study has a two-fold aim, and this is reflected in the structure and the content of this document:

- To identify any contentious issues related to the proposed routing, from the environment point of view.
- To provide the basis for the realization of the Preliminary Assessment of Environmental Requirements Procedure (ΠΠΠΑ in Greek), which is the first part of the Environmental Permitting Procedure according to the latest Greek Law (Law 4014/2011 ΦΕΚ 209/Α').

In this context, the study emphasises on important issues that may affect the feasibility of the proposed routing or introduce considerable cost implications. Such issues are the environmental designations of specific areas, the ecological characteristics and restrictions imposed by European and National Laws, Regulations and Local Authorities.

The study follows the general structure required by the Greek authorities for the Preliminary EIA. This structure provides for a description of the affected environment, a description of the proposed project including the alternative solutions, an evaluation of the possible environmental impacts caused by the development and the proposition of mitigation measures for those impacts.

2.2

Pipeline Routing – Alternative Routing Solutions

The routing of the High Pressure gas pipeline was chosen based on criteria as the safety of the population, the protection of ecosystems and the terrain structure. These criteria are the same as those observed in other high pressure gas pipelines designs of the existing Hellenic Gas Transmission System, which was recently relocated from DEPA and transferred to DESFA S.A.

2.2.1

Short Recommended Route Description

The Recommended routing of the pipeline has a total length of 30745.84m. (K0-K108), beginning at the Metering Station and Pigging Station (PS1), that are going to be installed in a common land plot near the existing Natural Gas Station of DESFA, which is located in the Industrial Area of Komotini, and ending at the connection point of the Greek section of the pipeline with the rest (Bulgarian) section of the pipeline at the border of Greece – Bulgaria.

With direction from south to north, the routing is located consecutively as follows:

Segment K0-K22 (0–11.5km): The routing of the pipeline has north western direction at first and northern afterwards, starting westwards from the Industrial Area of Komotini from the Metering Station and Pigging Station (PS1) "KOMOTINI" that are going to be installed in a common land plot near the existing Natural Gas Station of DESFA, it continues north from the settlement Fylakas, southern at first and western afterwards from the settlement Thylorio, eastern from the settlement Roditis and the city of Komotini and ends between the settlements Karydia and Kalchas, passing through extended cultivated areas of cotton and wheat.

The main crossings are with the asphalt road Fylakas – Thylorio (1.5km), the under study DESFA Greece – Italy (IGI) natural gas pipeline and the existing Komotini - Thessaloniki natural gas pipeline of DESFA (2.5km), the Old National Road Alexandroupoli – Komotini (5.2km), a stream (9.6km) and at the end the asphalt road Ifaistos – Stylario (10.8km).

Segment K22-K36 (11.5-15.3km): With north western direction the routing of the pipeline passes southern at first and western afterwards from the settlement Tychiro, passing through hilly area of gentle slopes with cultivations, trees and heath parts and crosses the asphalt road to Tychiro (12.4km), the under construction (construction works haven't started yet) New National Road "Komotini – Nimfea – Greek-Boulgarian Border – Axis 75" (13.3km) and the asphalt road Karydia – Pandrosos (14.6km).

Segment K36-K108 (15.3–30.7km): The routing of the pipeline has northern direction, passing western at first and northern afterwards from the settlement Pandrosos, western from the settlement Nimfea, from the Block Valve Station (BV1) "Nimfea" (27km), which

will be located 4km about west from the settlement Mytikas, it continues western from the settlement Ano Mytikas and ends to the Greek – Bulgarian border, passing through mountainous area with trees and heath parts. It crosses mostly the ravine Karydorema (15.3 & 17.7km) and the New National Road "Komotini – Nimfea – Greekboulgarian Borders – Axis 75" (28km) above a tunnel that has already been constructed.

Concerning the administrative structure of the routing, the pipeline is located at the Region of East Macedonia – Thrace, at the Prefecture of Rodopi and at the Municipality of Komotini.

2.2.2

Short description of alternative routes

2.2.2.1

Alternative Routing 1 (ALT-1)

The Alternative routing 1 of the pipeline has a total length of 28588.82m., beginning at the existing Natural Gas Station of DESFA, which is in the south western edge of the Industrial Area of Komotini and ending at the connection point of the Greek section of the pipeline with the rest (Bulgarian) section of the pipeline at the border of Greece – Bulgaria.

With north western direction, the Alternative routing 1 is located consecutively as follows:

Segment 0-11.1km: The routing of the pipeline has north western direction, begins from the existing Natural Gas Station of DESFA, which is in the south western edge of the Industrial Area of Komotini, continues south at first and west afterwards from the settlement Thrylorio, eastern from the settlement Roditis and the city of Komotini and ends south eastern from the settlement Karydia, passing through extended cultivated areas of cotton and wheat. The main crossings are with the asphalt road Fylakas – Thrylorio (1km), the Old National Road Alexandroupoli – Komotini (4.4km), a stream (9.4km), the under construction (construction works haven't started yet) New National Road "Komotini – Nimfea – Greek-Boulgarian Borders – Axis 75" (10.2km) and at the end the asphalt road Ifaistos – Stylario (11km).

Segment 11.1-15km: With north western direction the routing of the pipeline passes eastern at first and northern afterwards from the settlement Karydia, south western at first and western afterwards from the settlement Tychiro and ends south eastern from the settlement Pandrosos, passing through hilly area of gentle slopes with cultivations, trees and heath parts. It crosses mostly the asphalt road Karydia – Pandrosos (14.4km) and at the end a stream (14.7km).

Segment 15–28.6km: The routing of the pipeline has northern direction, passing western from the settlement Pandrosos, continues eastern from the ancient Byzantine castle at the area of Pandrosos, western from the settlement Ano Mytikas and ends to the Greek – Bulgarian borders, about 400m western from the end

of the Recommended routing. It is passing through mountainous area with trees and heath parts and crosses the asphalt road to the army camp of Nimfea at many points and the New National Road "Komotini – Nimfea – Greek-Boulgarian Border – Axis 75" (26.1km) above a tunnel that has already been constructed.

2.2.2.2

Alternative Routing 2 (ALT-2)

The Alternative routing 2 of the pipeline has a total length of 30262.13m., beginning at the Metering Station and Pigging Station (PS1), that are going to be installed in a common land plot near the existing Natural Gas Station of DESFA, which is in the Industrial Area of Komotini and ending at the connection point of the Greek section of the pipeline with the rest (Bulgarian) section of the pipeline at the border of Greece – Bulgaria.

With direction from south to north, the Alternative routing 2 is located consecutively as follows:

Segment 0–12.2km: With north western direction, the routing of the pipeline starts south western of the Industrial Area of Komotini, it continues south at first and west afterwards from the settlement Thrylorio, eastern from the settlement Roditis and the city of Komotini and ends western from the settlement Karydia, passing through extended cultivated areas of cotton and wheat.

The main crossings are with the under study DESFA Greece – Italy (IGI) natural gas pipeline and the existing Komotini - Thessaloniki natural gas pipeline of DESFA (1.4km), the asphalt road Fylakas – Thrylorio (1.9km), the Old National Road Alexandroupoli – Komotini (5.6km), a stream (10.6km), the under construction (construction works haven't started yet) New National Road "Komotini – Nimfea – Greek-Boulgarian Border – Axis 75" (11.2km) and at the end the asphalt road Ifaistos – Stylario (12.2km).

Segment 12.2-18km: The routing of the pipeline has northern direction, passes north eastern from the settlement Karydia, western at first and northern afterwards from the settlement Pandrosos, passing through hilly area of gentle slopes with cultivations, trees and heath parts. It crosses mostly the asphalt road Karydia – Pandrosos (15.9km) and at the end a stream at many points.

Segment 18–30.3km: The routing of the pipeline has northern direction, passing western from the settlements Nimfea and Ano Mytikas and ends to the Greek – Bulgarian borders, 900m about eastern from the point that the Recommended routing ends. It is passing through mountainous area with trees and heath parts and crosses mostly the New National Road "Komotini – Nimfea – Greek-Boulgarian Border – Axis 75" (28.4km) above a tunnel that has already constructed.

2.3

Works Area – Routing Philosophy

The routing of the High Pressure gas pipeline was chosen based on criteria as the safety of the population, the protection of ecosystems and the terrain structure. The construction works are carried out over a Working Width (ROW) of 22 m total for the 28" pipeline (or 26m for 36" pipeline).

The works consist of the reception trench opening, performing welding of pipeline, the lowering, inspection and testing of the pipeline and finally its cover. Especially for woodland and perennial crops, the work zone will be reduced to 16 m total for the 28"-36" pipeline.

2.4

Environmental Aspects & Impacts

The Environmental Aspects and Impacts of the project are mainly connected with its design and construction phases.

During the design (mainly the routing selection) the best solution should be selected in order NOT to create problems in environmentally sensitive areas, maintaining in the same time the engineering and financial viability of the whole project.

The limited environmental impacts of the project occur during the construction phase and are presented in Chapter 7. During its operational phase the project shall not pose any significant environmental threat.

It is concluded that with the implementation of careful initial routing design in close co-operation with the state and local authorities and the provision of all the measures dictated by the International Standards, there shall not be any significant adverse effects from the construction works. The guidelines & recommendations of the local authorities are taken into consideration in order to minimize the environmental impacts.

The positive consequences of the construction and operation of the proposed pipeline for both the environment and the local and national economy should be noted with emphasis.

2.5

Protection & Reinstatement Measures

After completion of construction work, the work area will be restored to its original state. The restorations, beyond the horizontal area of restoration work, concern the restoration of the natural intersections / artificial barriers, the protection of slopes, the relocation of any plant systems and finally the restoration of the beauty and unity of the landscape area along the project route.

Conclusions

The Proposed Routing is the best both technically and environmentally, compared with two (2) other options that were examined. The present Preliminary Environmental Impact Assessment report has examined any impacts that may arise from this and proposes the necessary measures of protection. Special emphasis has been given in the identification of areas that may create problems in the development of the project.

It is concluded that the project, during its construction and operation phases, does not cause any significant, long-lasting and irreversible impacts both to the physical and the man-made environment so that a **positive Initial Environmental Assessment and Evaluation pronouncement is proposed.**

2.7

Summary of Project Data

PROJECT	
NAME	Interconnector Greece-Bugaria (IGB) Project - Greek Part
TYPE	High Pressure (>25bar) Natural Gas Pipeline
PROJECT SIZE	Pipeline Diameter : 28" (or larger) Pipeline Length : 30.7 Km (Proposed routing) Design Pressure : 80 barg
LOCATION	Regional Department of Rodopi Region of Eastern Macedonia & Thrace
PROJECT OWNER	ICGB AD
ADDRESS	66 Pancho Vladigerov Blvd., District Lyulin 2, Sofia, Bulgaria.
REPRESENTATIVE	
	Project Manager: Mr. Vanyo Slaveikov Telephone: +359 888 567 180 e-mail: v.slaveikov@gmail.com Deputy Project Manager: Konstantinos Parthenis Telephone: +30 210 2701262 e-mail: k.parthenis@depa.gr
EIA STUDY TEAM	
ENGINEER	Consortium PENSPEN Ltd – C&M Engineering S.A.
ADDRESS	99, Pratinou str., 11634 Athens, Greece
TELEPHONE	+30-210-7220014
FAX	+30-210-7220298
E-MAIL	mail@cmengineering.gr
PROJECT RESPONSIBLE	Emmanuel Kaliorakis